

ColonyCam

VOGUE

User Guide v1.5



SINGER
INSTRUMENTS

A RESPONSIBILITY TO SCIENCE!

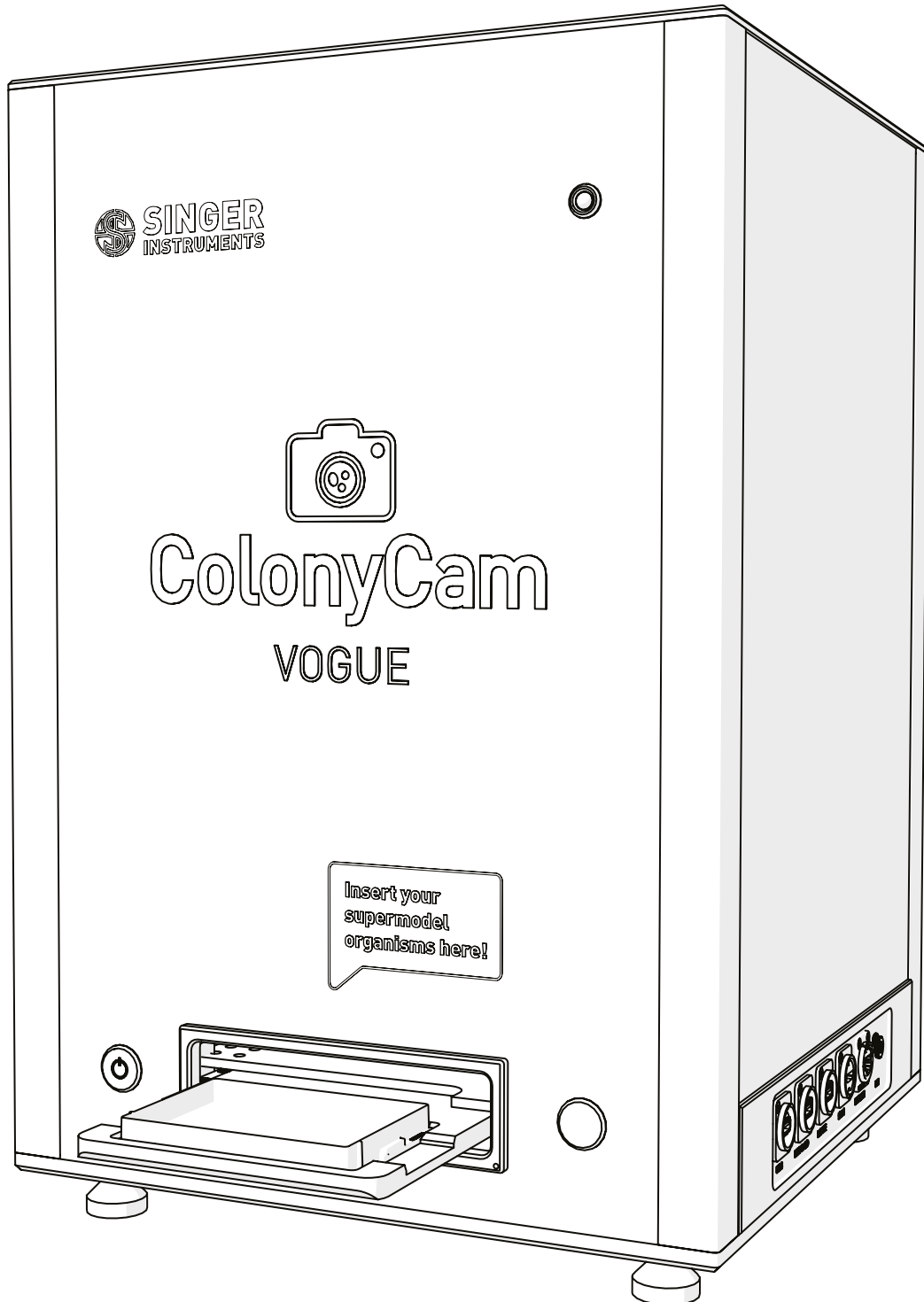

For more support
resources visit
[bit.ly/
ColonyCamhelp](https://bit.ly/ColonyCamhelp)

Read before you start!

Plate Height Restrictions!

The ColonyCam Vogue is designed to accept SBS format plates and 90 mm Petri Dishes. There is a maximum plate height limit (including the lid) of 22mm, Deep-well plates will not fit.

Image with the lid on.

To conserve your sample integrity you can image the plate with the lid on. Reflections and glare have been minimised to still give a high quality image. Images taken with the plate lid on will turn out slightly darker.

Keep your hands clear while the drawer is moving.

Catching your hands in the drawer may cause injury.

The drawer opens automatically.

Keep the area in front of the drawer clear as it will open automatically throughout the capture stage.

Remember to remove your last plate before pressing finish.

The drawer will retract when you press finish. Make sure to remove your last plate from the drawer before you press the finish button.

Remove Plate and Petri adaptor before moving the ColonyCam.

If you need to move the ColonyCam for any reason, make sure any plates are removed from the machine as well as the Petri Dish adaptor. These items can fall from the input tray and become lodged inside the ColonyCam.

Gamma Correction.

ColonyCam is configured to give the highest degree of data integrity and visual acuity. ColonyCam applies a gamma correction of 0.54 to ensure the images are displayed correctly to the human eye. Gamma correction is an appropriate image processing technique on scientific images so long as the process is applied to all data consistently and that data integrity is maintained. Given that this process is applied to all images and is carefully calibrated by Singer Instruments, both of these conditions are met. The gamma correction can be essentially reversed by applying the reciprocal gamma. Specifically, applying a gamma of 1.85 in image processing software such as ImageJ will linearise the data which may be appropriate for some image analysis workflows such as quantification of colony brightness/pixel intensity.

ColonyCam images are large.

We recommend removing unwanted images from the default file location regularly to avoid running out of internal storage space.

We'd love your feedback!

We'd love your feedback on our new imaging device, ColonyCam! Perfect for publishable quality images and a great starting point for downstream analysis.

Please scan the QR Code or email ux@singerinstruments.com with any feedback.



Join our discovery community!

Join our Discovery community and help us make the product features YOU want.

The Discovery Community is a group of scientists helping us to understand and solve anything causing frustration in their lab.

Help us to shape product development and have a say in future product updates. You'll also get early access to new features and be able to test things before release.

We'll even throw in some cheeky vouchers, Singer discounts and maybe even some cake!

Scan the QR Code or visit bit.ly/DiscoCommunity to join.



2	Read before you start!
3	Join our Discovery Community
4	Introduction
5	Technical Specification
6	Out of the Box
7	Anatomy & Features
10	Unboxing & Assembly
13	ColonyCam Vogue Workflow
14	Manually entering the plate name
17	Automating the plate name
19	Updating ColonyCam Vogue
21	API Mode
23	Using ColonyCam with PhenoSuite
24	Setting up PhenoSuite to run without a PhenoBooth
26	Using ColonyCam with PhenoSuite
29	Best Practice
30	Status LED/ Cleaning
31	Liquid Plates Mode/ Safely Eject the USB drive
32	Software Icons
33	Troubleshooting

ColonyCam

Introduction

ColonyCam Vogue is a high-quality imaging device producing publishable quality photographs, a great starting point for downstream analysis. ColonyCam Vogue can image standard SBS plates, 90mm Petri Dishes and Singer Plus Plates.

The information in this guide relates to software version:
1.1.1

ColonyCam Vogue Technical Specifications v1.1

General

- Automated door and drawer for SBS format plates
- 90mm petri adapter

Dimensions

- Length: 400mm (15.75")
- Width: 404mm (15.9")
- Width (Drawer Open): 513mm (20.2")
- Height: 612mm (24")

Weight

- 22.5Kg

Power Requirements

- 110-240V AC 50-60Hz
- External Power Supply: 24V DC, 5A

Computer Specification

- OS: Ubuntu 22.04 LTS
- Memory: 16 GB
- Storage: 1 TB
- Processor: Intel Core i7
- Display Resolution: 1920 x 1080

Lighting

- White light illumination (Top lit, Diffuse)
- Colour temperature 4000K

Camera

- 20 megapixel colour camera
- Field of view 150x100mm
- 36 pixels/mm at mid-plate agar depth
- Fixed focus lens at 5mm agar depth
- Depth of field +/- 5mm

Drawer Movements

- Speed:180mm/s
- Acceleration:1000mm/s²

Connectivity

- (1x) USB 3.0
- (2x) USB 2.0
- (1x) HDMI
- Ethernet

Out of the box

Find out what comes with the ColonyCam. We'll take you through the steps involved in unboxing and assembling ready for imaging.

Anatomy & features

Front

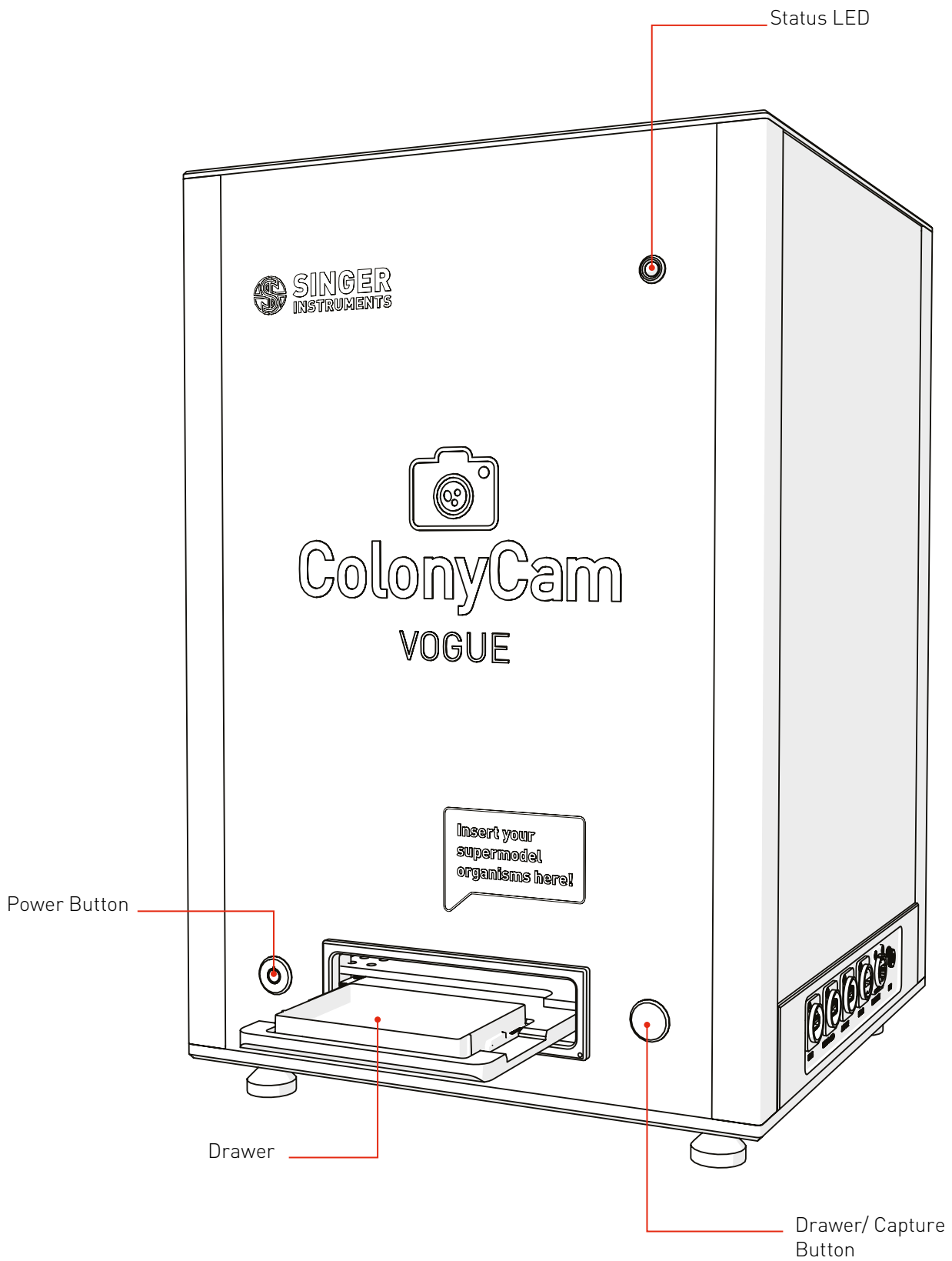

Anatomy & features

RH Side - Sockets

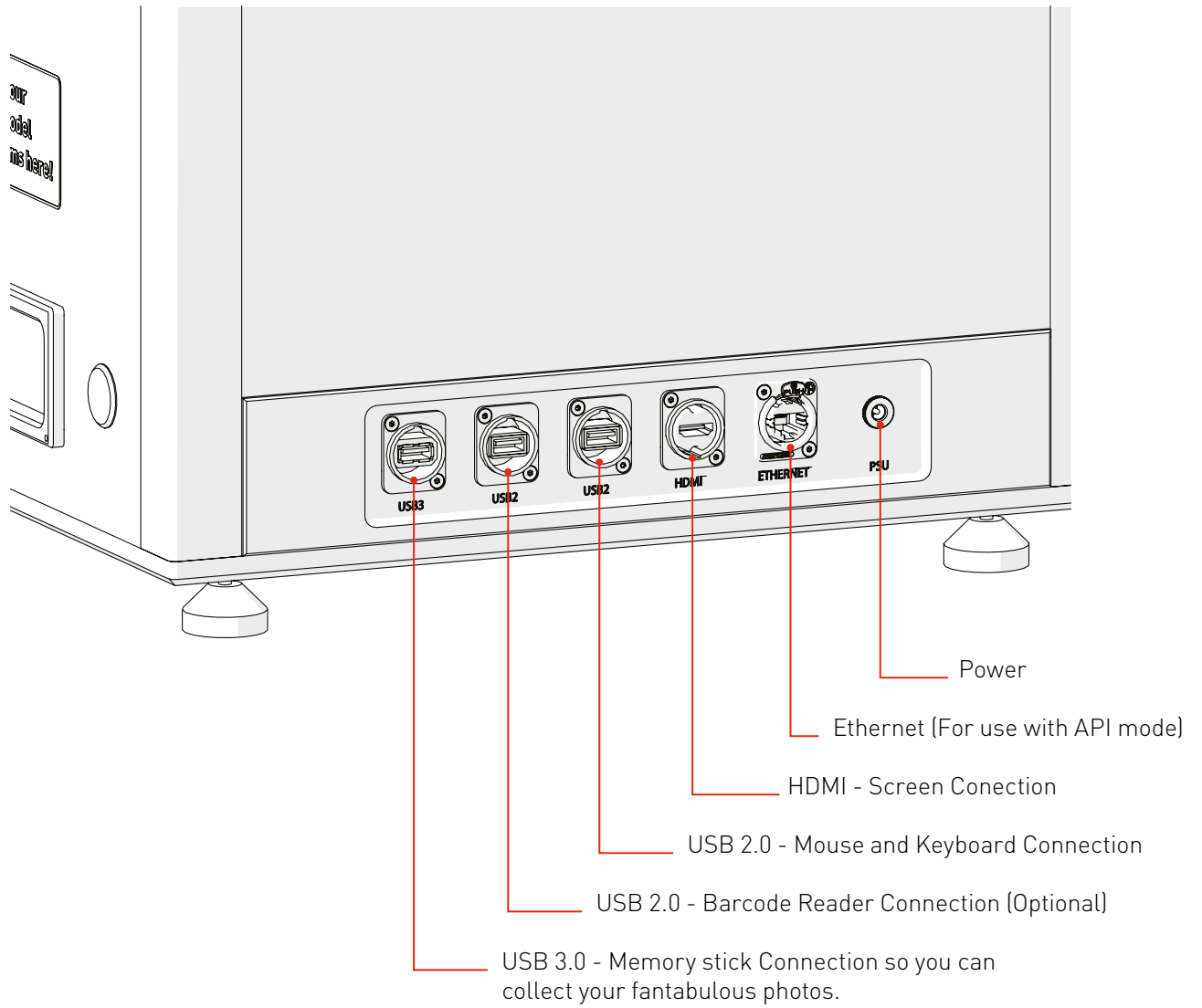

Anatomy & features

Software Set-up Screen

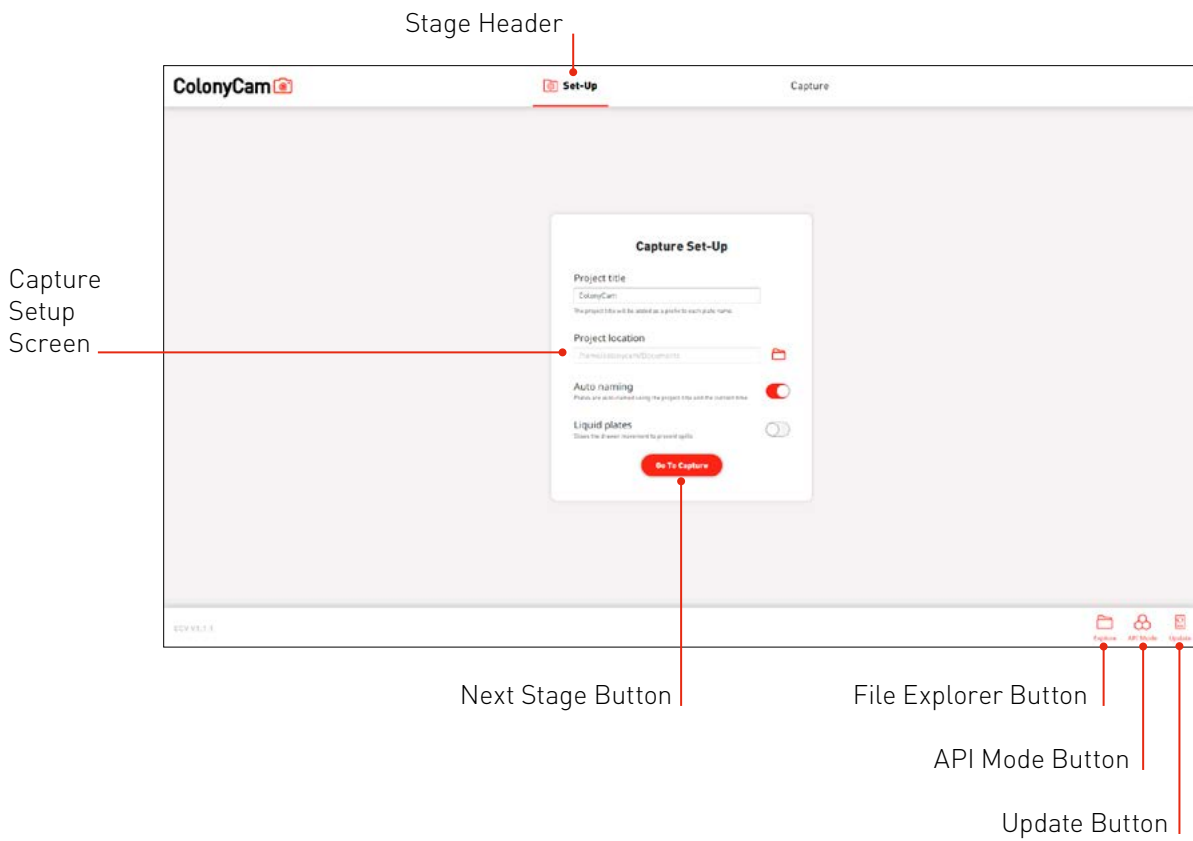

Capture Screen

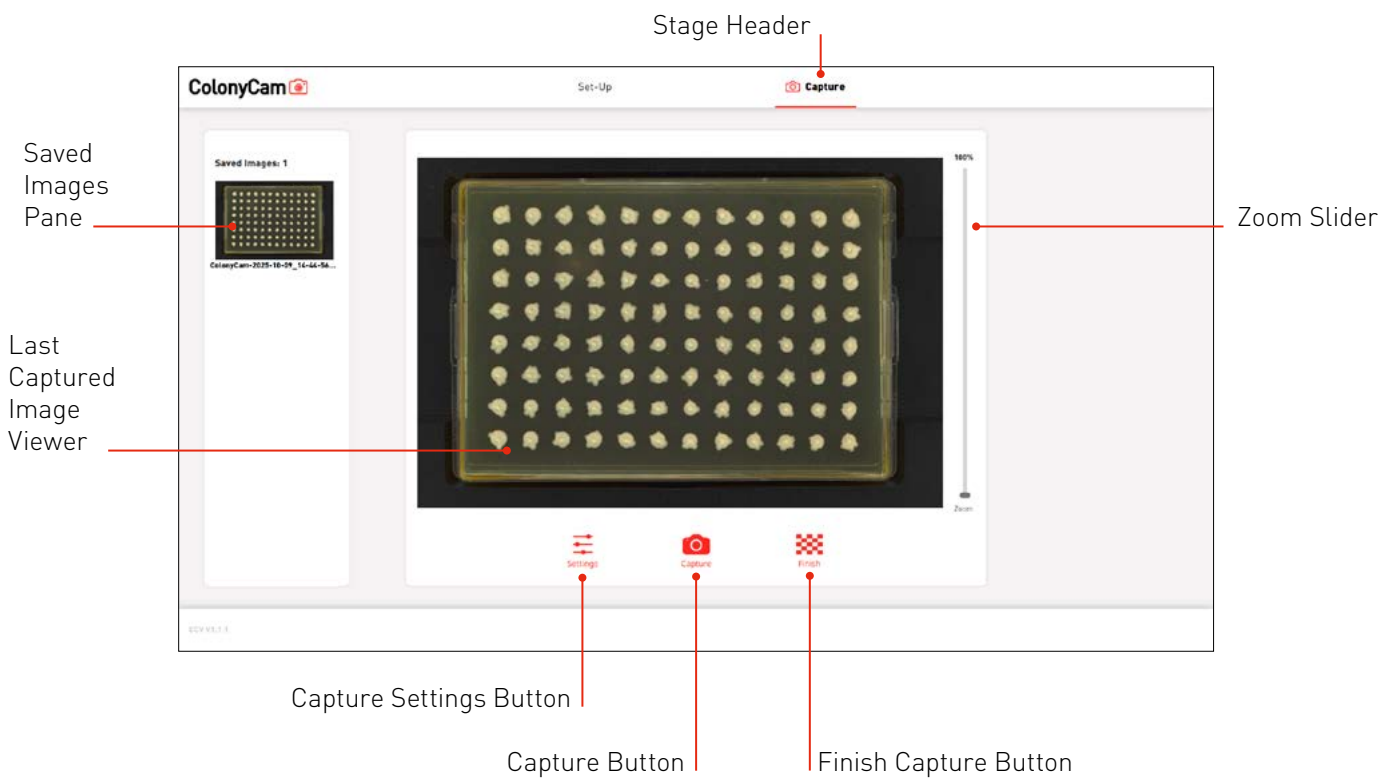

Unboxing & Assembly

ColonyCam Box

1. ColonyCam
2. ColonyCam power supply
3. 90 mm petri dish adaptor
4. HDMI Cable

1.

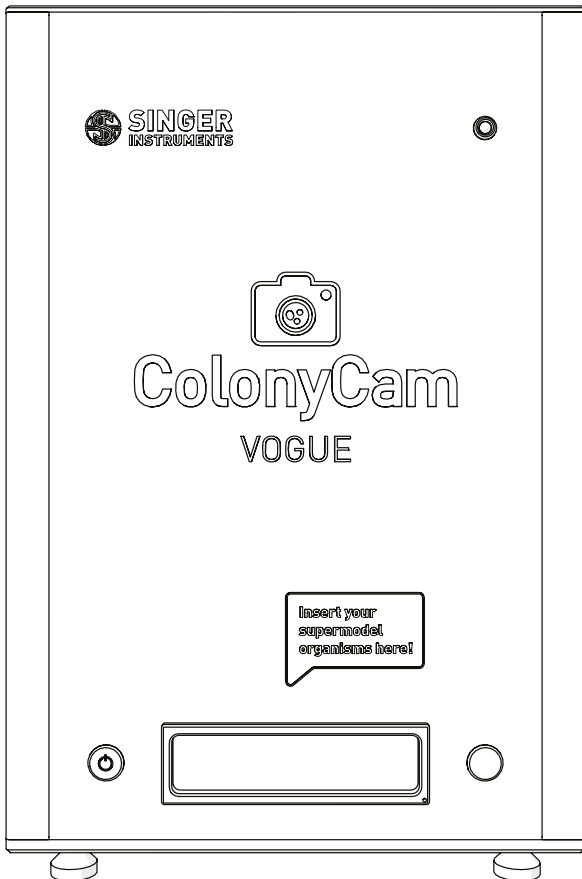

2.

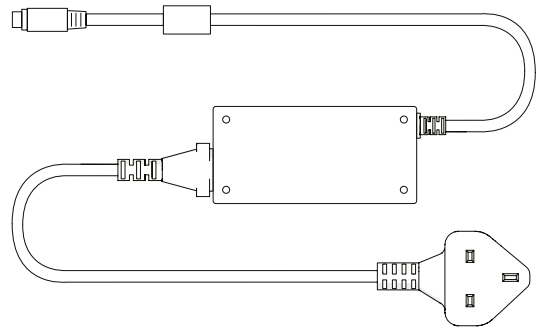

3.

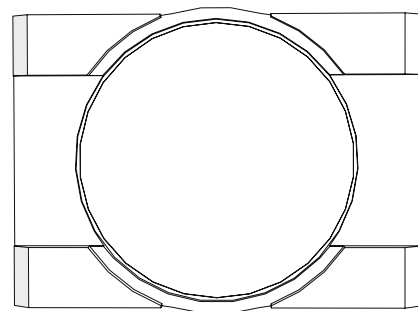

Additional Items

5. Monitor box (includes Dell monitor, stand and connections)
6. Computer Keyboard
7. Computer Mouse
8. 2.5mm Allen Key

Unboxing & Assembly

Setting up the System

1

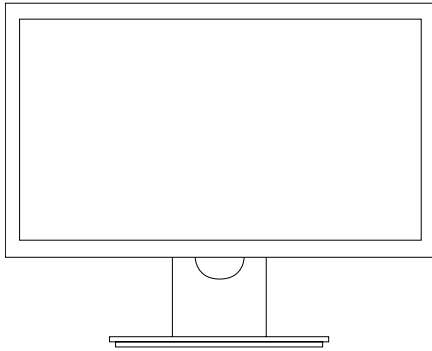

- Set up the monitor as detailed in the screen box instructions.

2

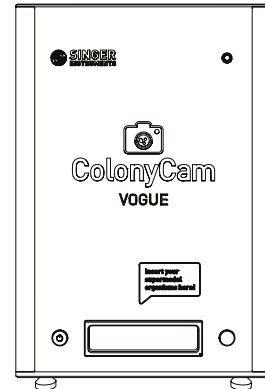

- Carefully remove the ColonyCam out of the box using good manual handling practices and stand on your workspace.
- **Heavy: May require 2 people**

3

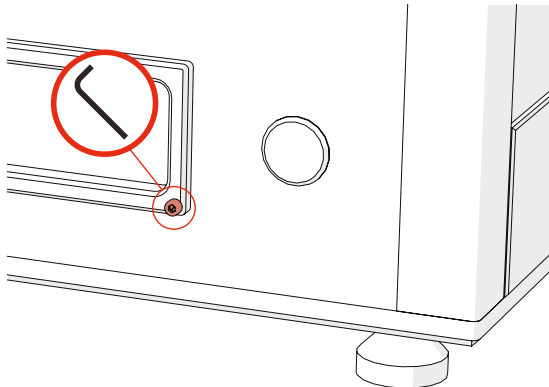

- Remove the transit screw using the supplied allen key.
- NOTE: The transit screw should always be removed before powering on ColonyCam.

4

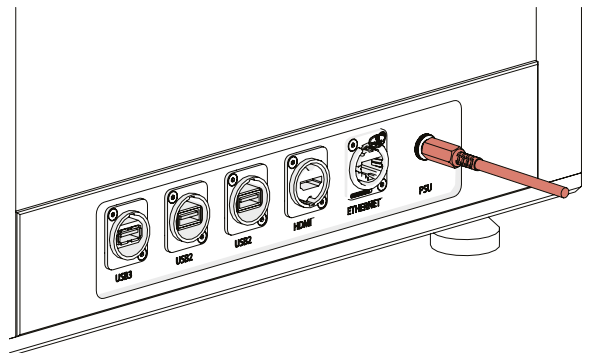

- Insert the ColonyCam power supply into the power socket on the side of the machine.

5

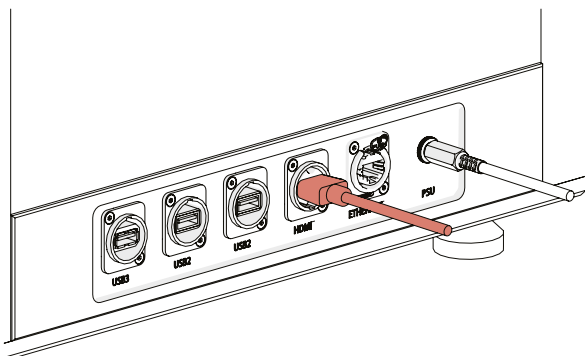

- Connect the ColonyCam to the screen using the supplied HDMI cable.

6

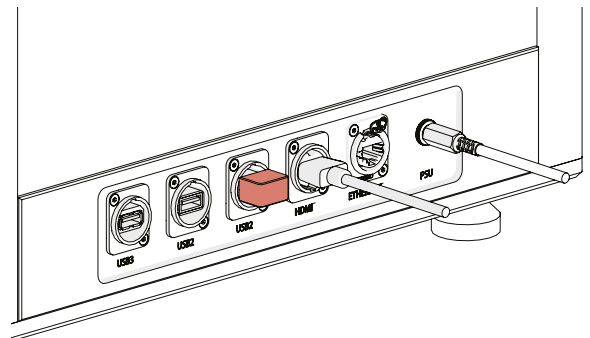

- Connect the keyboard and mouse dongle to one of the USB 2.0 sockets on the side of ColonyCam.

Unboxing & Assembly

7

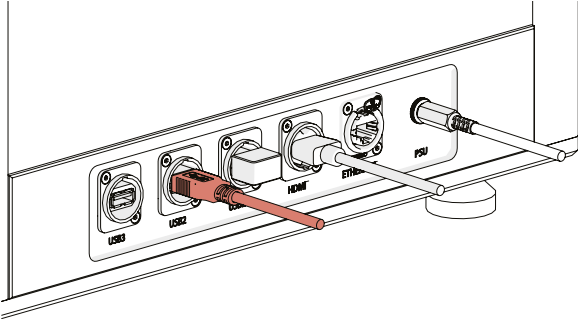

- [OPTIONAL] Attach a barcode scanner to the second USB 2.0 Socket if using.

8

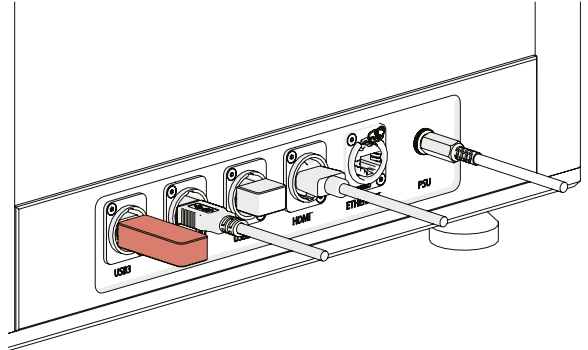

- Insert a memory stick into the USB 3.0 socket.
- QUICK TIP: Specify this location as your file location in the software for quick access to your images later on in the process.

9

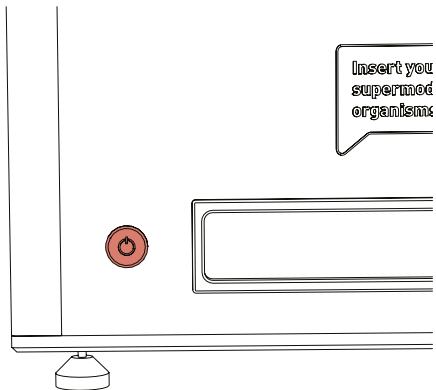

- Ensure that the screen is powered on and press the power button to turn on the ColonyCam.
- The ColonyCam software will automatically load.

ColonyCam Vogue Workflow

Let's take a quick tour of the ColonyCam Vogue workflow. Getting set up and taking your first fantabulous photo. The software will load shortly after turning on the ColonyCam.

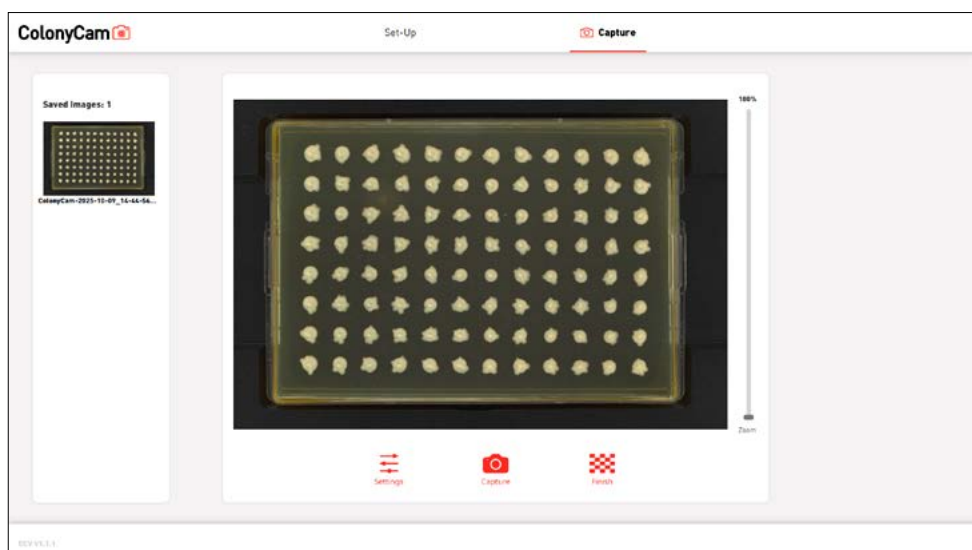

Workflow - Manually Entering the Plate Name

1

- Ensure that the ColonyCam and screen are setup correctly. See the previous setup guide for details (p11).
- Turning on ColonyCam will automatically load the software. (This takes around 5 seconds)
- You are presented with this Capture Set-up screen. Fill out the optional *File name prefix* and specify the desired *File location*.
- NOTE: (File name prefix is optional as we'll be naming the image in the next step)
- When you're happy with the settings, press 'Go To Capture' to continue.

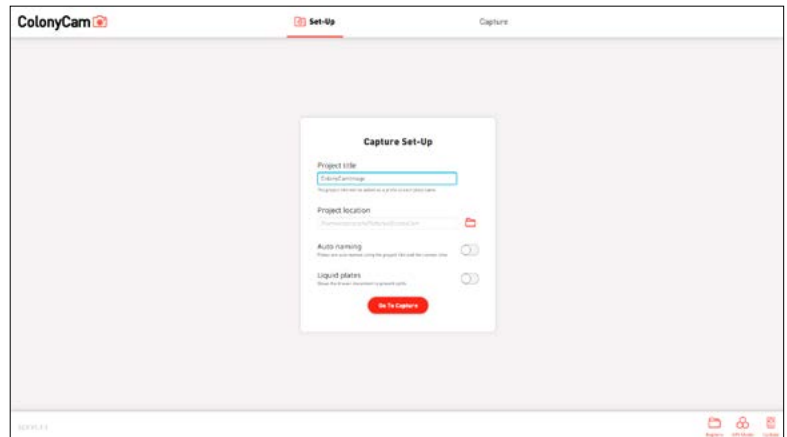

2

- A popup box will appear asking to name your image. If you added a prefix during set-up, this will be retained.
- A barcode scanner can also be attached to ColonyCam (use the spare USB 2.0 port) to input a barcode in this field.
- When you're happy with the name, press *Continue* to move onto the capture stage.

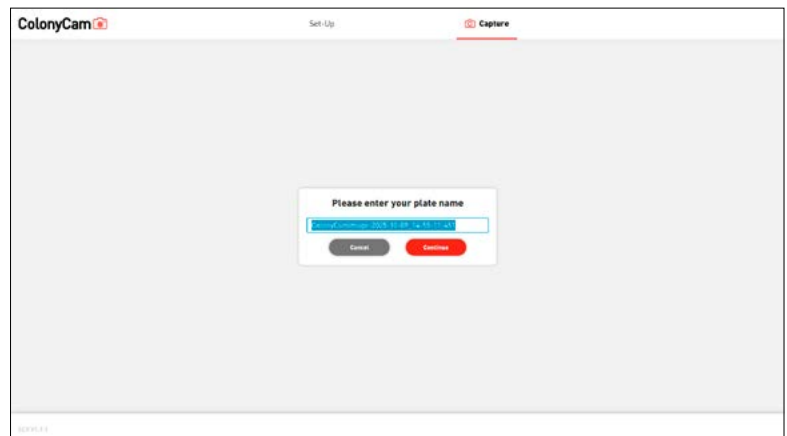

3

- You will see an instruction to load a plate.
- The ColonyCam will automatically open the door, so ensure that the area in front of ColonyCam is clear.
- Insert a plate into the drawer and press the *Capture* button on the front of ColonyCam or press the pop-up *Capture* button. This will retract the drawer and automatically take the first image.
- NOTE: The ColonyCam accepts either SBS format single well plates or 90 mm Petri Dishes*.

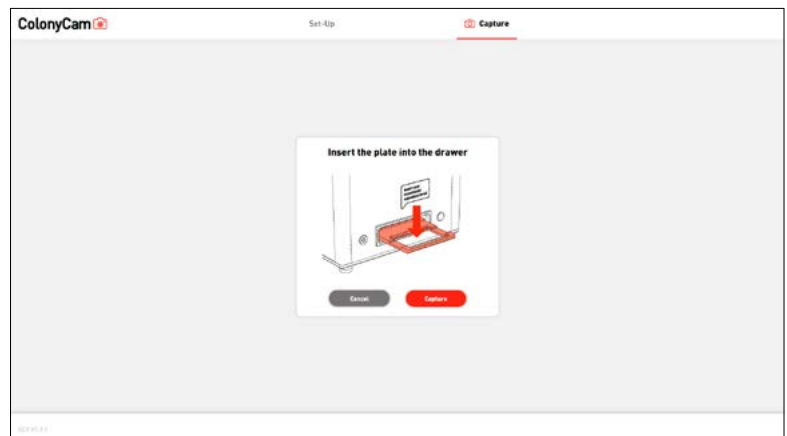

Workflow - Manually Entering the Plate Name

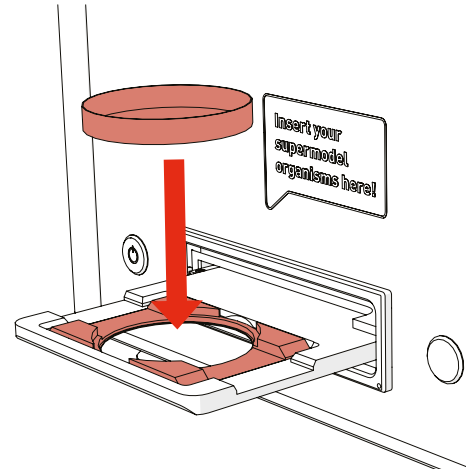
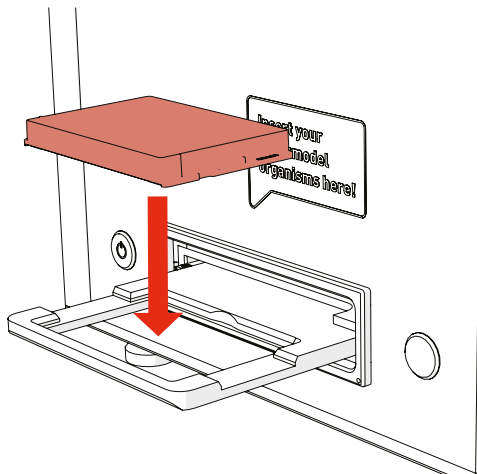

*The provided Petri Dish Adaptor needs to be used to image 90 mm Petri Dishes.

4

- Each image is automatically saved (as a .png file) to your chosen file location and displayed in the image viewer.
- The saved images are also displayed on the left of the screen with the custom name.
- The zoom slider on the right can be used to zoom into the image.
- NOTE: Once the image has been taken the drawer will eject with the plate, so keep the front of ColonyCam clear.

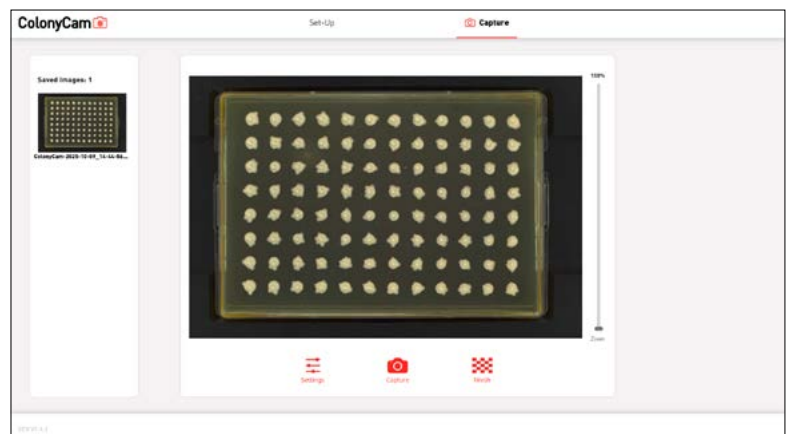

4

- To continue the workflow remove the plate and insert the next plate to image. Press the capture button on the front of ColonyCam or the software *Capture* button.
- Fill out the naming dialogue box and press continue to take the image.
- Repeat this step for all of your remaining plates.

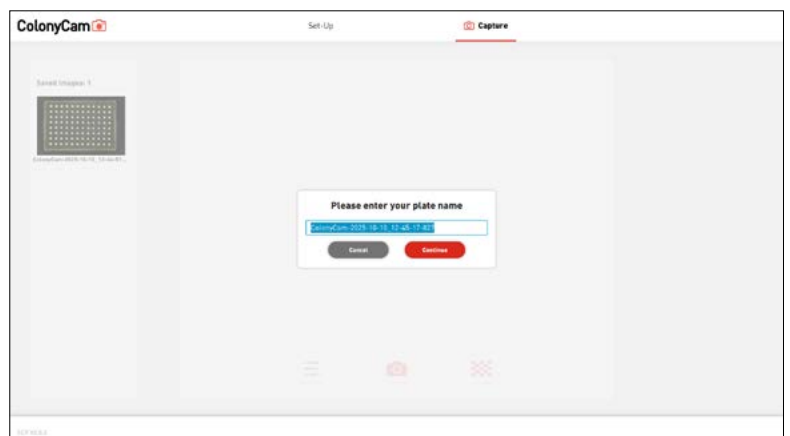

Workflow - Manually Entering the Plate Name

5

- When you have finished capturing all of your plates, press the *Finish* button.
- A pop up box will appear reminding you to remove the last plate from ColonyCam. Remove the plate and press *Close Drawer* to continue.

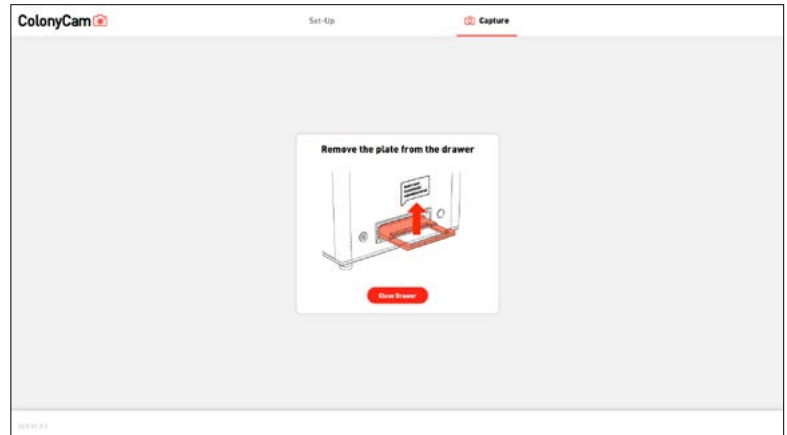

6

- You will be returned to the original Capture set-up screen and a Summary pop up will appear with the number of images taken and a link to the image folder.
- To access your images click on the link to open the image folder.

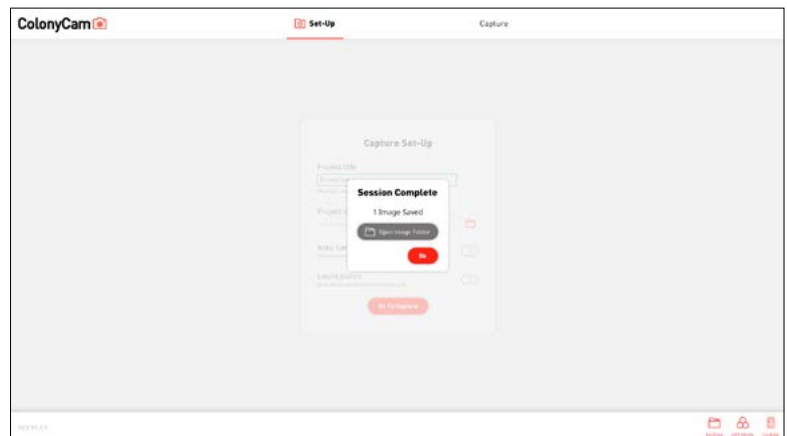

Workflow - Automating the Plate Name

1

- You can also automate the plate name by turning on the *Use timestamp as File Name* toggle and filling out the *File Name Prefix* box.
- This will then apply your naming prefix and a timestamp to each image automatically.
- The file location can also be specified as before.
- When you're happy with these naming settings, press *'Go To Capture'* to move onto the next stage.

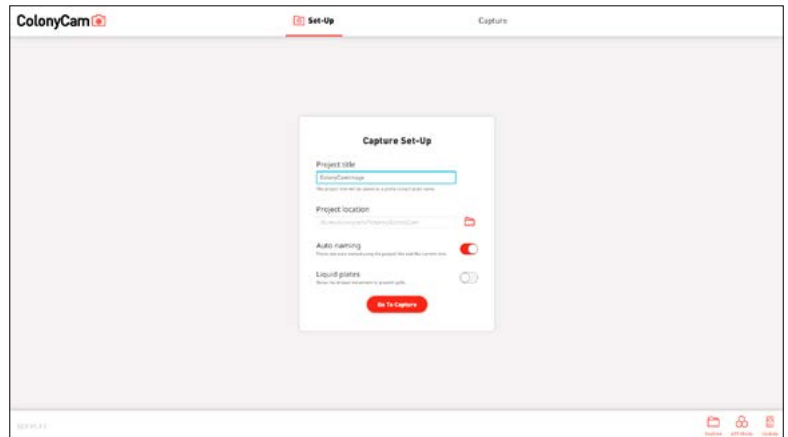

2

- You will see an instruction to load a plate.
- The ColonyCam will automatically open the drawer for you when you press *'Go To Capture'*. Ensure that the area in front of the drawer is clear.
- Insert a plate into the drawer and press the Capture button on the front of the ColonyCam or press the software *Capture* button.
- NOTE: The ColonyCam accepts either SBS format single well plates or 90 mm Petri Dishes*.

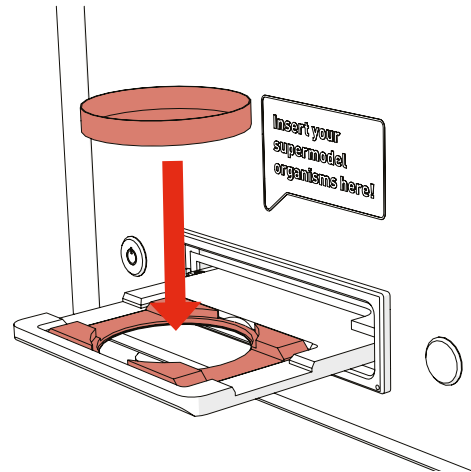
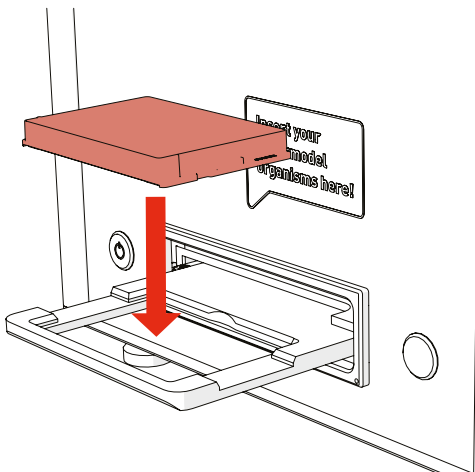
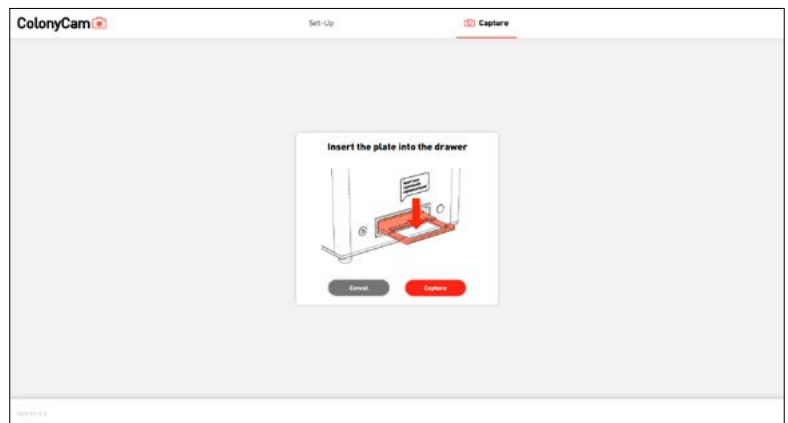

*The provided Petri Dish Adaptor needs to be used to image 90 mm Petri Dishes.

Workflow - Automating the Plate Name

3

- ColonyCam will now take the image. This takes approximately 5 seconds. Each image is automatically saved (as a .png file) to your chosen file location and displayed in the image viewer.
- The saved images are also displayed on the left of the screen with their prefix and timestamp.
- The zoom slider on the right can be used to zoom into the image.
- NOTE: Once the image has been taken the drawer will eject with the plate. Remember to keep the area in front of the drawer clear.

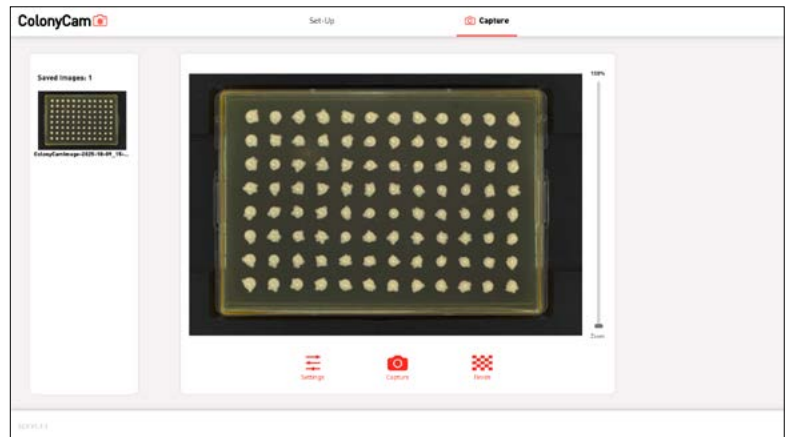

4

- To continue the workflow remove the plate and insert the next plate to image.
- Press the *Capture* button on the front of ColonyCam or press the software *Capture* button.
- Once captured the image will appear in the picture viewer and in the *Saved Images* column with its new prefix and timestamp.
- Repeat steps 2 - 3 for as many plates as required.

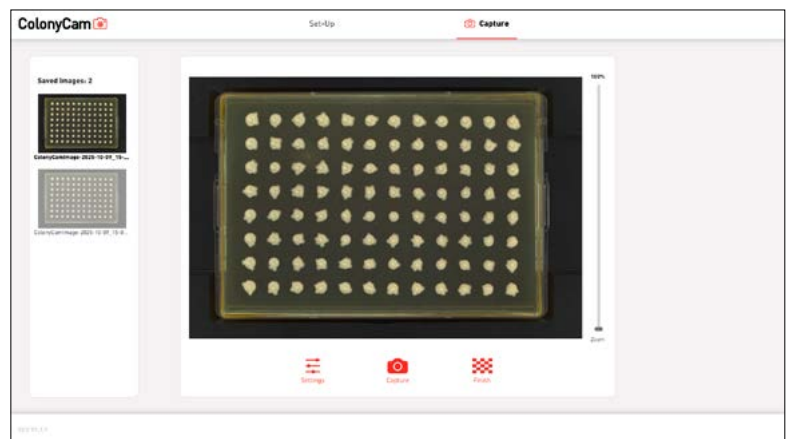

5

- When you have finished capturing all of your plates, press the *Finish* button.
- A pop up box will appear reminding you to remove the last plate from ColonyCam. Remove the plate and press *Close Drawer* to continue.
- You will be returned to the original Capture set-up screen and a Summary pop up will appear with the number of images taken and a link to the image folder.

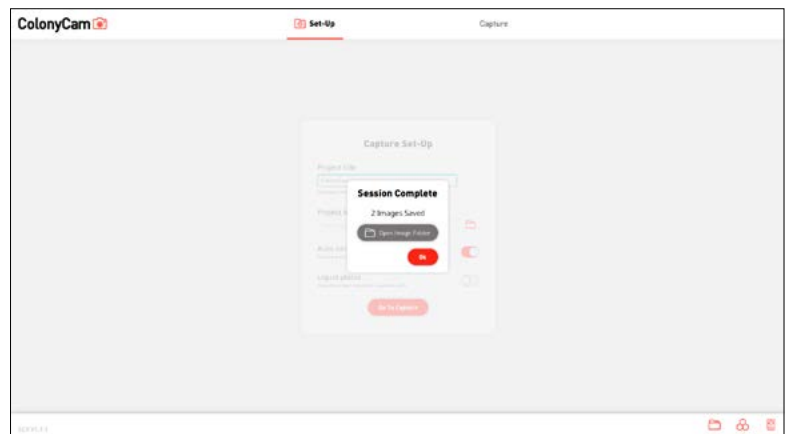

Updating ColonyCam Vogue

We are always working on new features and functionality for our products. When a ColonyCam update is available we'll send you an email with a download link. Save the downloaded file to a USB drive and follow the next few steps to complete the update.

Updating the ColonyCam

1

- When a ColonyCam update is available we'll email you with a download link to a zip file. Make sure this is saved to a USB drive.
- Insert the USB drive into the ColonyCam computer and press the *Update* button in the lower right hand corner of the screen. This will open the file explorer.

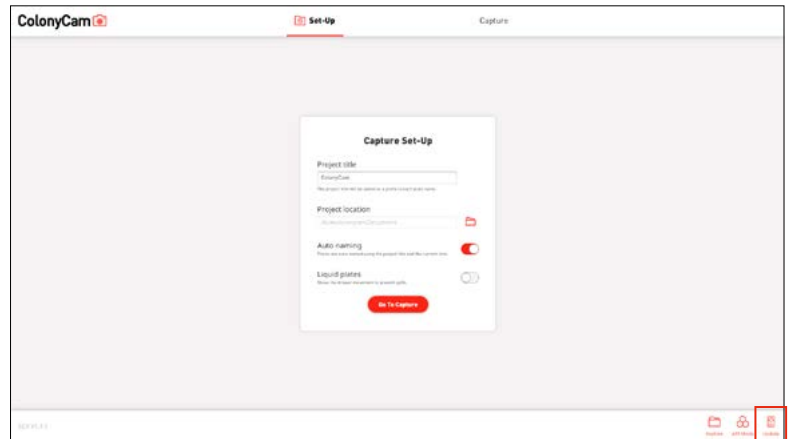
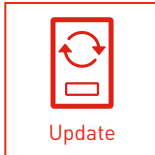

2

- With the file explorer open, navigate to the USB drive. Select the zip file and press *Open*.

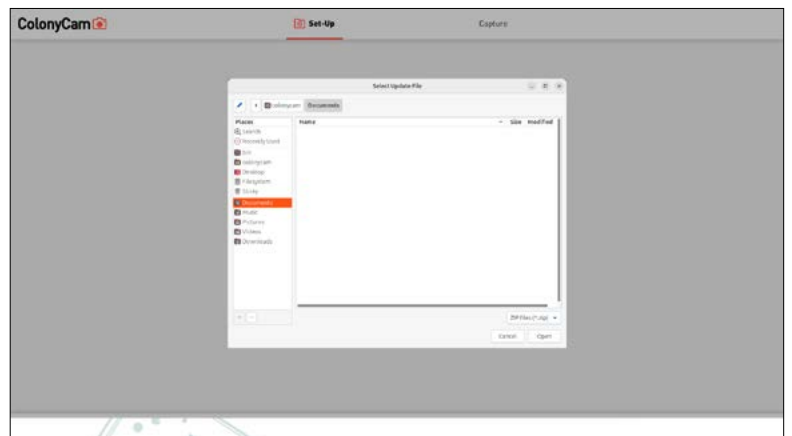

3

- Once the file has been opened you need to restart ColonyCam for the update to begin.
- Once ColonyCam has restarted, please follow any onscreen prompts.
- Your ColonyCam is now updated and ready to use again!

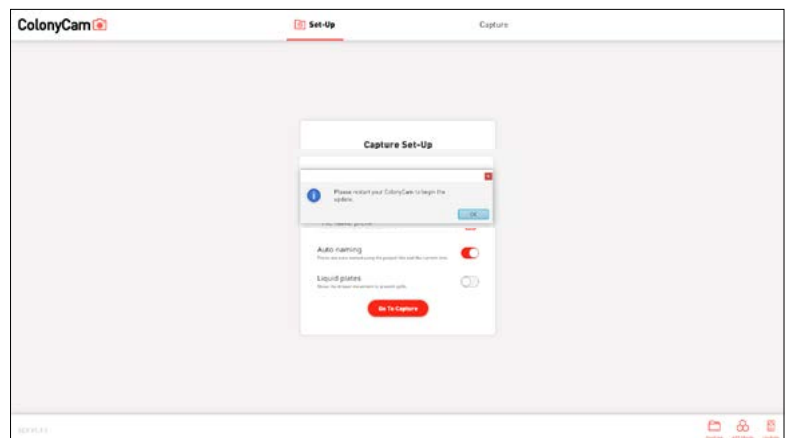

API Mode

API mode can be switched on to control ColonyCam from an external PC as part of a bigger workflow. Here's how to turn it on in the software.

For a full breakdown of how to use ColonyCam in API mode please scan the QR code below to visit the API tech site.



API Mode

1

- Connect ColonyCam to an external computer using the supplied Ethernet cable.

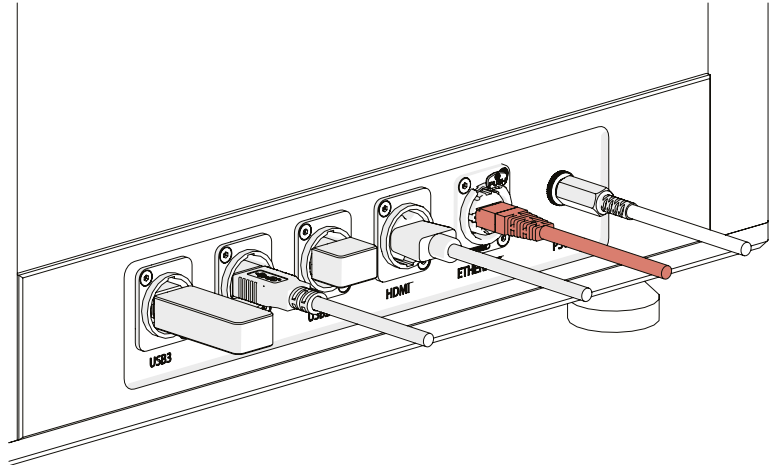

2

- Ensure you are on the Capture Setup Screen.
- Press the API Mode icon to access API mode.

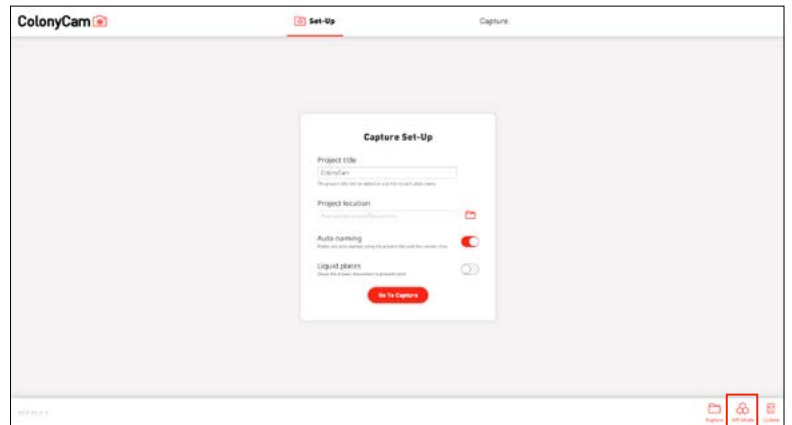

3

- ColonyCam can now be controlled by the external computer. Please scan the QR code on P20 to learn how to use API mode.
- Start ColonyCam in API mode every time by turning on the *Start in API Mode* toggle. ColonyCam will remember this the next time its switched on.
- To turn off API mode, press the *Stop API* button and you will return to the Capture Setup Screen.

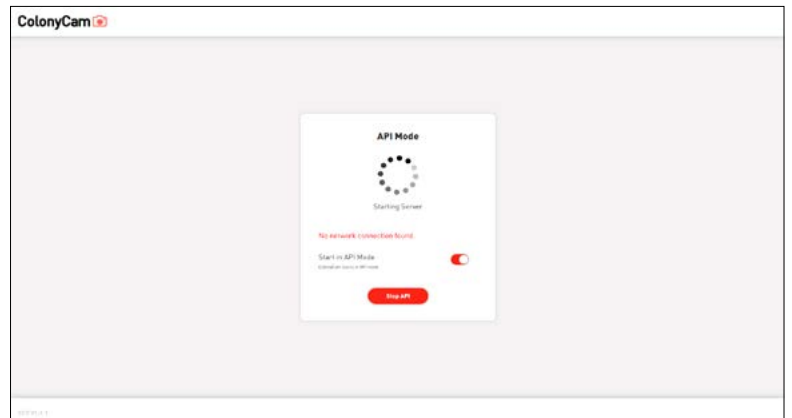

Using ColonyCam with PhenoSuite

Images taken with ColonyCam can be processed using our image analysis software, PhenoSuite. This guide shows you how to setup PhenoSuite to run without a PhenoBooth and then easily remove the images from ColonyCam ready to import into PhenoSuite.

Before you begin you need to setup PhenoSuite for use without a PhenoBooth, this will allow you to select the ColonyCam resolution and install all of the required drivers. Follow the guide on page 24.

For the best results we recommend:

- . Solid agar plates with PhenoSuite as analysis of liquid plates is not supported.
- . Image plates without the lids removed.

Setting up PhenoSuite to run without a PhenoBooth

1

- Open up PhenoSuite and begin by setting up a project.
- Press *OK* to continue.

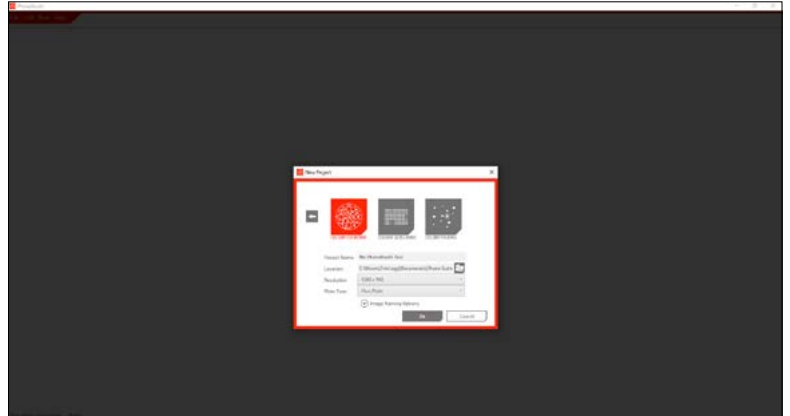

2

- Press File in the top left hand corner and select options.

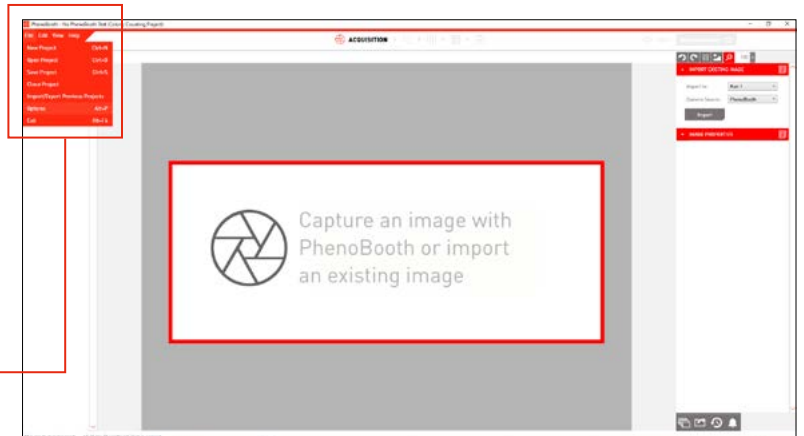
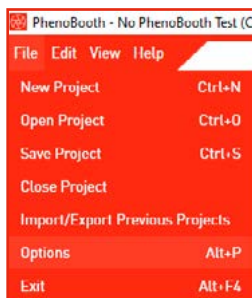

3

- Press the *PhenoBooth Version* button to continue.

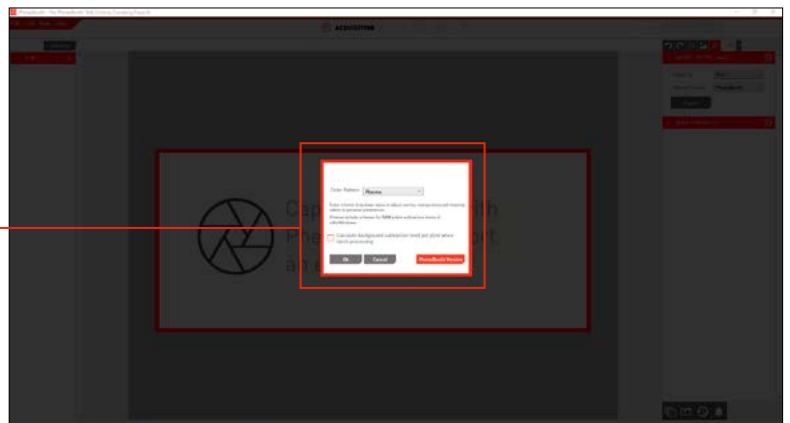
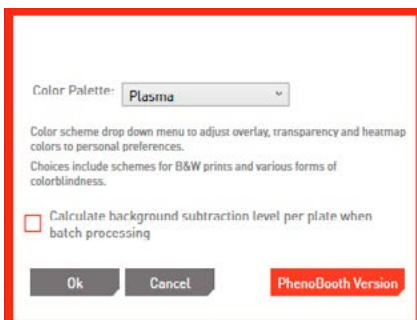

Setting up PhenoSuite to run without a PhenoBooth

4

- Select the PhenoBooth+ option and then click *Apply and Restart* to continue.
- Note: This allows PhenoBooth packages to be installed that PhenoSuite requires to run.

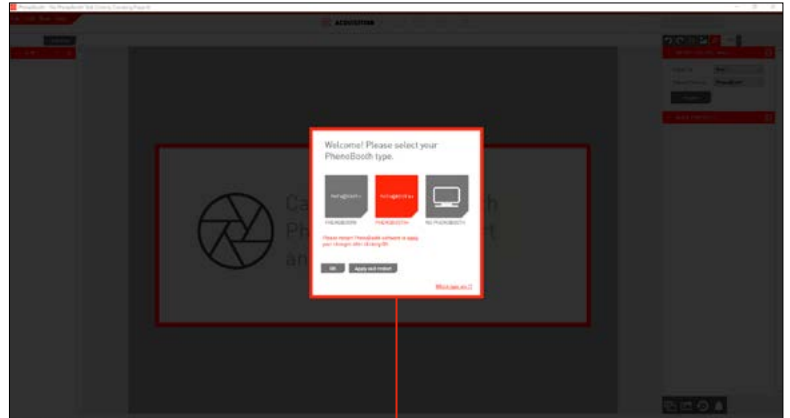

5

- Once your machine has restarted, navigate back to the *Phenobooth Version* panel.
- Select *No Phenobooth* and then press *OK* to continue.
- Note: This allows you to select the ColonyCam resolution *(5472 x 3648)* when setting up a project.

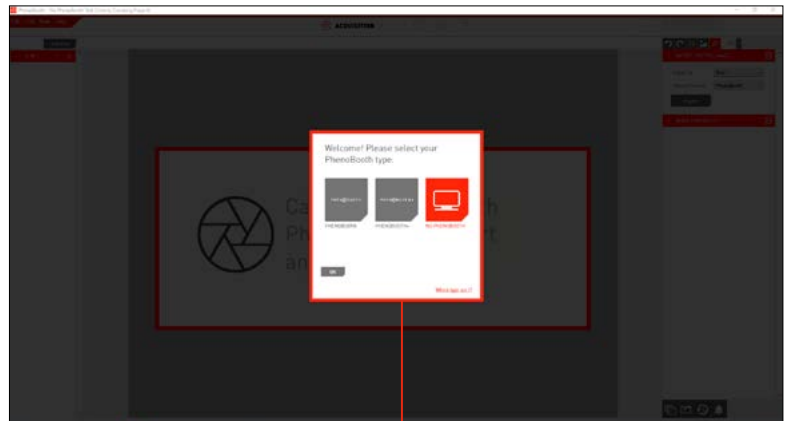

Using ColonyCam with PhenoSuite

1

- Follow the steps in the ColonyCam workflow section of this guide (p13-18) to take the images that you want to process with PhenoSuite.
- TIP: Attach a USB drive to the USB 3.0 port on ColonyCam and set as the file location to ensure easy image transfer.

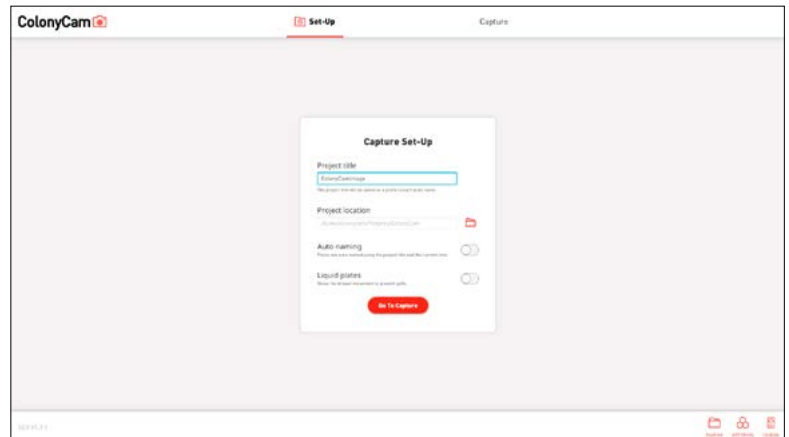

2

- Safely eject the USB drive using the *Eject USB Drive* option at the end of the imaging workflow.
- Transfer the images to a PC containing the PhenoSuite software.
- The images can now be used in two different PhenoSuite workflows; Colony Counting and Colony Screening.

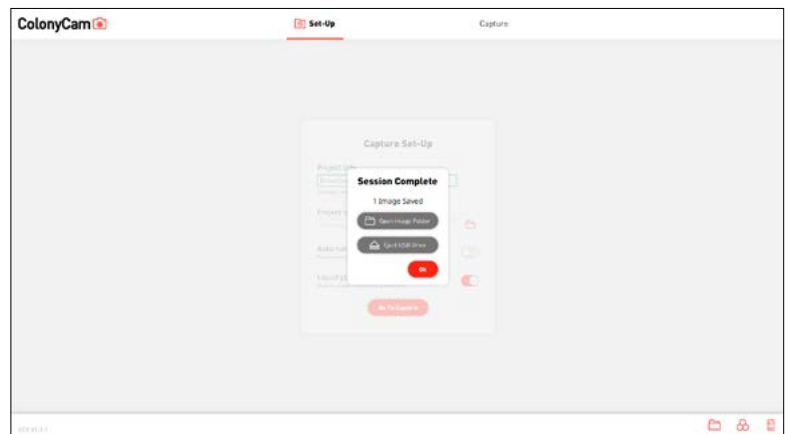

Colony Counting in Phenosuite

1

- Open the PhenoSuite software and select *Colony Counting*.
- Give the project a suitable name
- Set the resolution to the ColonyCam setting (5472 x 3648).
- Press *Ok* to continue

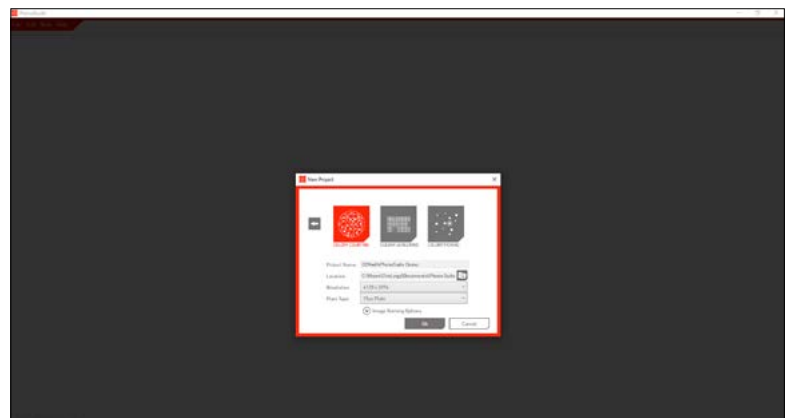

Using ColonyCam with PhenoSuite

2

- In the top right hand corner select *Run 1* from the drop down and the camera source to *Other*.
- Press *Import* and select the required ColonyCam images from the file explorer.

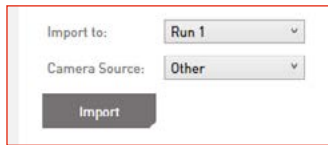

- Press *Pre-processing* to continue with the colony counting workflow.

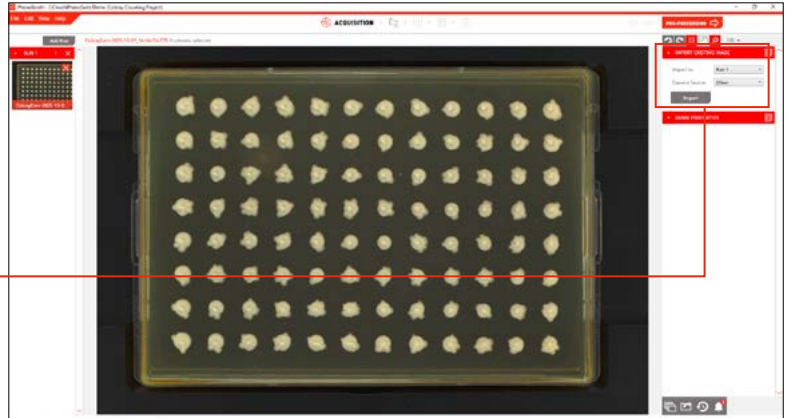

Colony Screening in Phenosuite

1

- Open the PhenoSuite software and select the *Colony Screening* option.
- Give the project a suitable name.
- Set the resolution to the setting (5472 x 3648).
- Press *Ok* to continue.

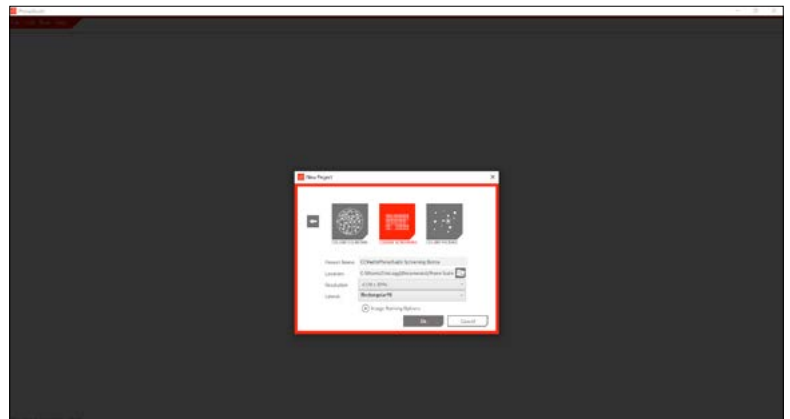

2

- In the top right hand corner select *Run 1* from the drop down and the camera source to *Other*.
- Colony Screening requires separate control and experiment images.
- First untick the Assign plate type checkbox.
- Select the *Control* option and *Import* the required control image.

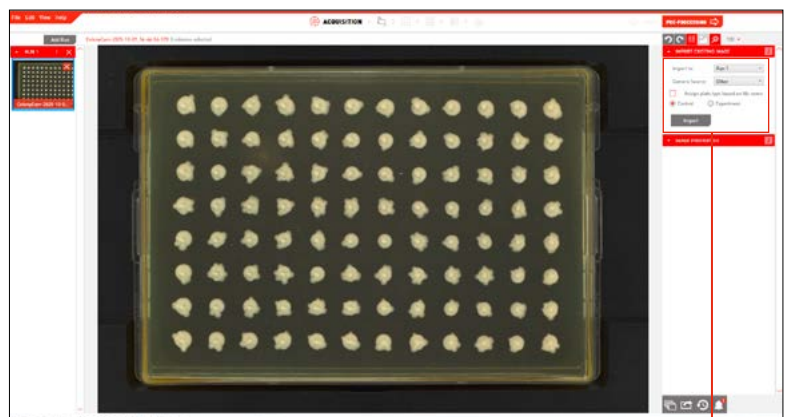
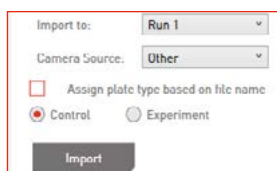

Using ColonyCam with PhenoSuite

3

- Next select the *Experiment* option and *Import* the required experiment image.

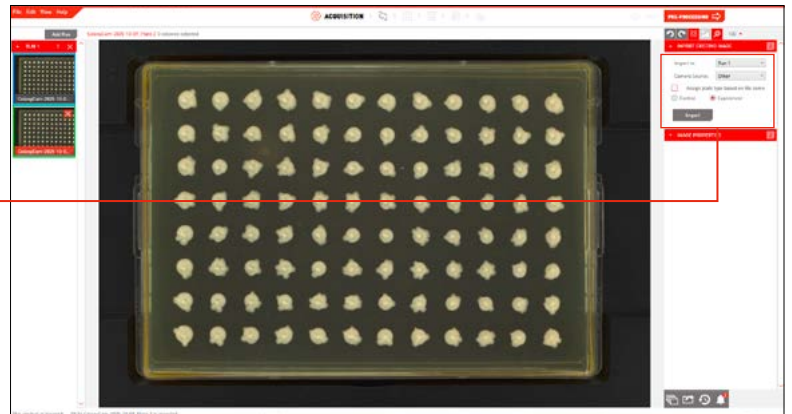
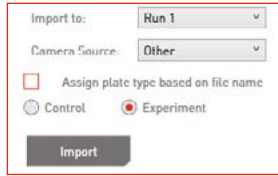

- Press *Pre-processing* to continue with the colony counting workflow.

Using Phenosuite

- The previous steps allow you to successfully import images from ColonyCam and process them using PhenoSuite.
- For a full breakdown of how to use PhenoSuite, please scan the QR Code to see the PhenoSuite user guide.



Best Practice

We want you to have a trouble-free time with your ColonyCam so we've assembled some handy hints, tips and troubleshooting answers to keep you on the straight and narrow.

Status LED/ Cleaning

Status LEDs

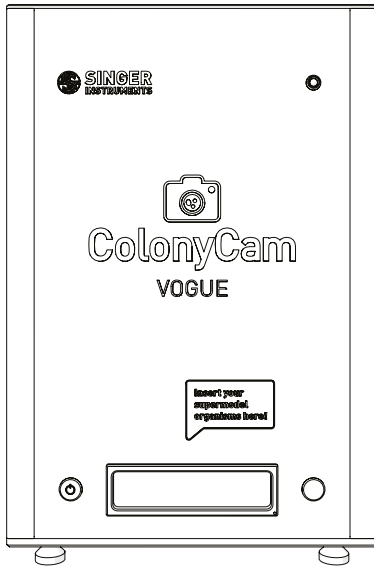

- GREEN. The ColonyCam is ready to use.
- ☀️ FLASHES GREEN. The ColonyCam is taking a Phantabulous photo.
- ☀️ FLASHES AMBER. (1) The ColonyCam will flash amber just after the machine is turned on and is booting up. (2) The machine will also flash amber when the drawer is moving.
- RED. There has been a hardware error. Turn the ColonyCam off and on again. If the issue persists, please contact techincalsupport@singerinstruments.com
- ☀️ FLASHES RED. The drawer has crashed. Press the capture button to recover and re-home the drawer.

Cleaning

The Drawer

We recommend wiping down the drawer surface with a clean cloth dampened with 70% ethanol.

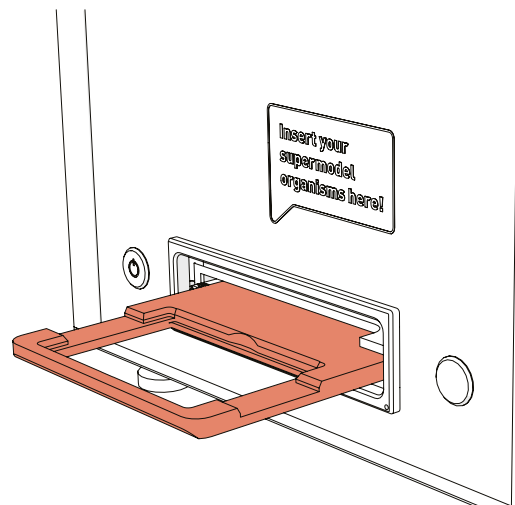

Petri Dish Adapter

The surface of the petri dish adapter can also be cleaned using a clean cloth dampened with 70% ethanol.

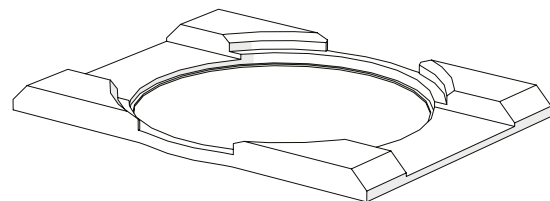

Liquid Plates Mode/ Safely Eject the USB Drive

Liquid Plates Mode

- When working with labware containing liquid, we recommend turning on *Liquid Plates* mode from the *Capture Set-Up* screen. This reduces the drawer speed to avoid spills.
- With Liquid Plates mode turned on, capture time takes approximately 8 seconds.

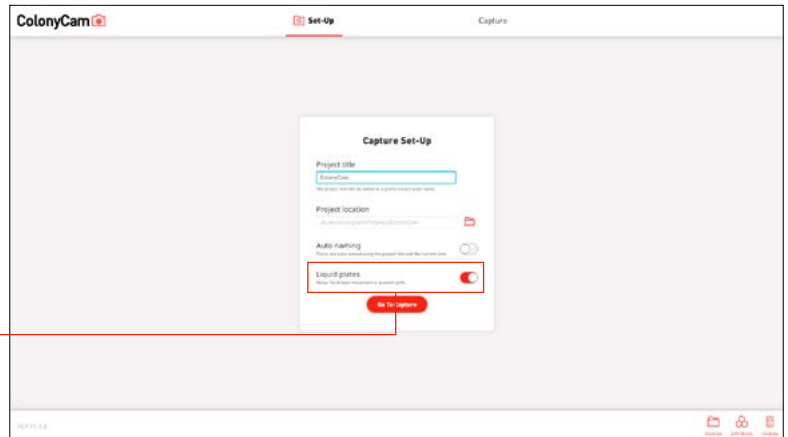

Safely Eject the USB Drive

- If a USB drive has been selected as the file location, an eject USB drive prompt will appear at the end of the imaging workflow.
- Press the Eject USB drive button to safely eject the USB drive.

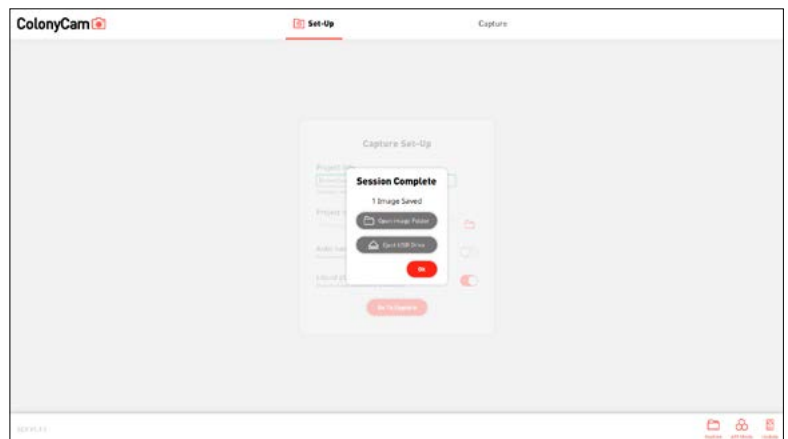

- A pop up box will shortly appear to tell you when it is safe to remove the USB drive.

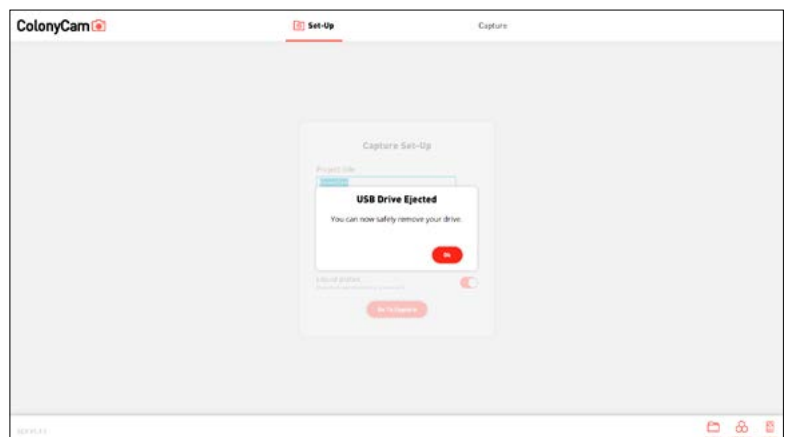

Software Icons

Top Bar (Stage Indicators)



Capture Set-up



Capture

Set-up Menu



Open File Explorer

Select where you want to save your images.

Capture Screen



Capture

Closes the drawer, takes a picture and opens the drawer.



Finish

Returns you to the Capture Set-up page.

Bottom Bar (Updates & Notification)



API Mode

Turns on API Mode and allows you to control ColonyCam with an external PC.



Update

Allows you to update your ColonyCam system.

Troubleshooting

Problem

The drawer has crashed.

There has been a hardware error and the red light is on.

My ColonyCam shows the disconnected icon.

Solution

Press the *Capture* button to recover and rehome the drawer.

Turn the ColonyCam off and on again. If the error persists contact technicalsupport@singerinstruments.com

Turn off the ColonyCam and PC. Ensure the ethernet cable is plugged in correctly into both devices.

Technical Support

Need help with a different PIXL Max issue?

If you have an issue that isn't covered please visit our tech support site using the QR code and submit a support ticket or email techsupport@singerinstruments.com



bit.ly/Supportrequest



Roadwater
Watchet
Somerset
TA23 0RE
UK

+44 (0)1984 640226 (tel)
+44 (0)1984 641166 (fax)

@singerinstruments.com
singerinstruments.com



Scan to visit our website for more helpful tips and tutorials!



/SingerInstruments

Follow us on our social media channels for updates on what we are up to next.

Disclaimer

At Singer Instruments, we are constantly seeking to improve our products and adapt them to the requirements of modern research techniques and testing methods. This involves modification to the mechanical structure and optical design of our instruments. Therefore, all descriptions and illustrations in this user guide, including all specifications are subject to change without notice.