

# SPORE™

PLAY+

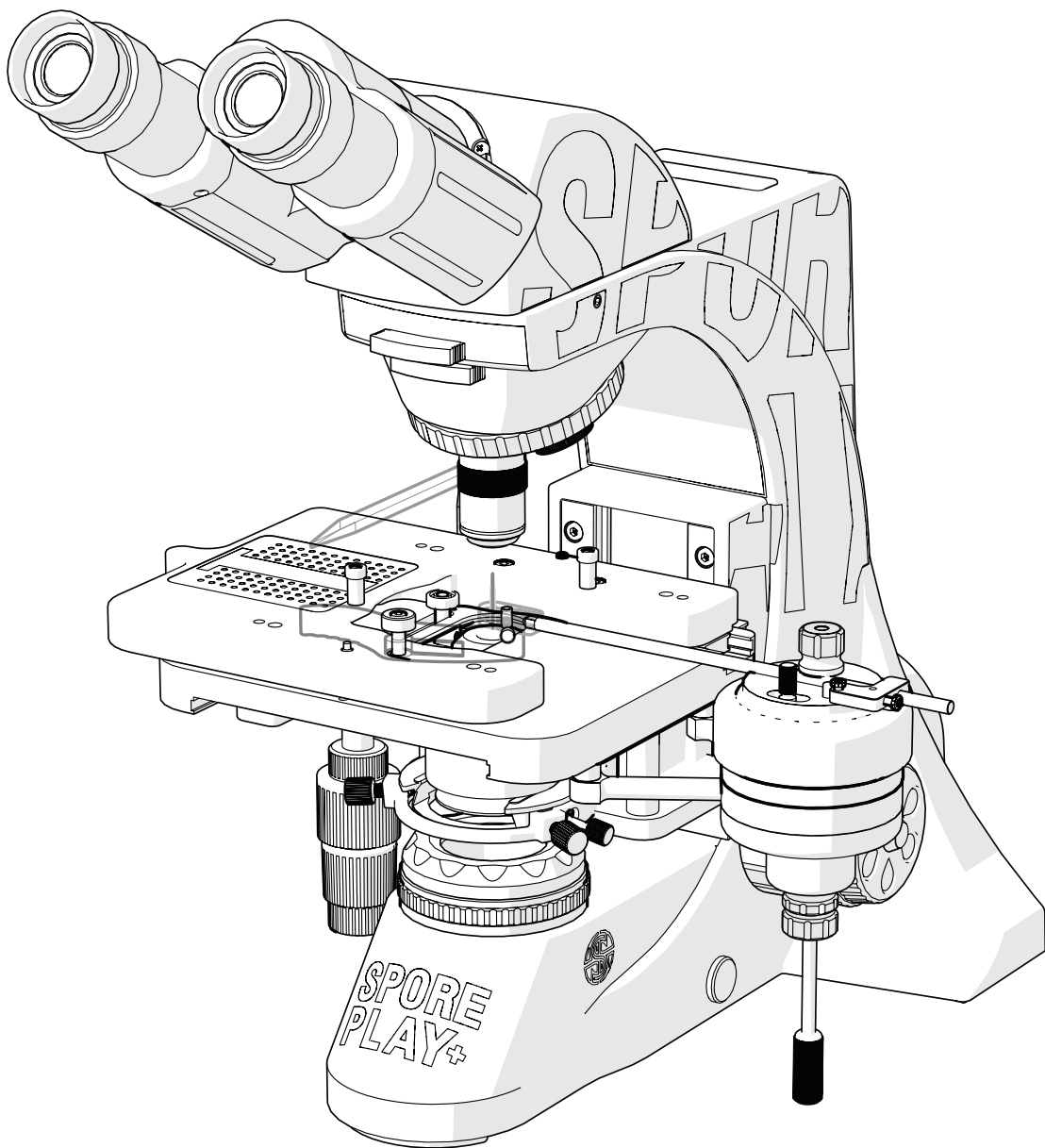



## BEFORE YOU START!

1. **Needle are sharp!** Take care when handling dissection needles as they are very sharp.
2. **Remove plate and tool holder before moving the SporePlay+.**  
To avoid equipment damage, ensure that all consumables and accessories are removed before moving the SporePlay+.
3. **Potential lighting delay.** If using the Auto Light Function detailed on page 6, there will be a slight light delay when switching between objectives.

PAGE	DESCRIPTION
4.	MICROSCOPE FEATURES Anatomy & features
6.	BASIC FUNCTIONS Adjusting nosepiece Powering up Adjusting lamp brightness Light control function
7.	STAGE & INDEX POINTER SYSTEM X, Y & Z Axis Adjustment Petri dish mount Index Pointer System
8.	MICROMANIPULATOR & NEEDLE HOLDER Unlock/lock mechanism X, Y, Z Axis joystick control Tool holder clamp Y Axis control lock Pinch release function Maintaining your SporePlay+
10.	Changing the filter
11.	Changing the condenser
12.	Marking the dish
13.	Notes

## **SPOREPLAY+™**

### **INTRODUCTION**

The SporePlay+ Modular Microscope Platform is an elegant, ergonomic and compact microscope for manual yeast and fungal tetrad dissection. With the integrated micromanipulator and index pointer, the SporePlay+ makes manual dissection as easy as it has ever been!

### **USER GUIDE**

Follow these instructions to get the most out of the SporePlay+ Modular Microscope Platform. This guide outlines basic functions of the SporePlay+ as well as useful tips for all the features. Read through this guide and you'll be ready for the exciting world of ultra-fast and precise manual dissection

### **DISCLAIMER**

At Singer Instruments, we are constantly seeking to improve our products and adapt them to the requirements of modern research techniques and testing methods. This involves modification to the mechanical structure and optical design of our instruments. Therefore, all descriptions and illustrations in this user guide, including all specifications are subject to change without notice.

## ANATOMY & FEATURES

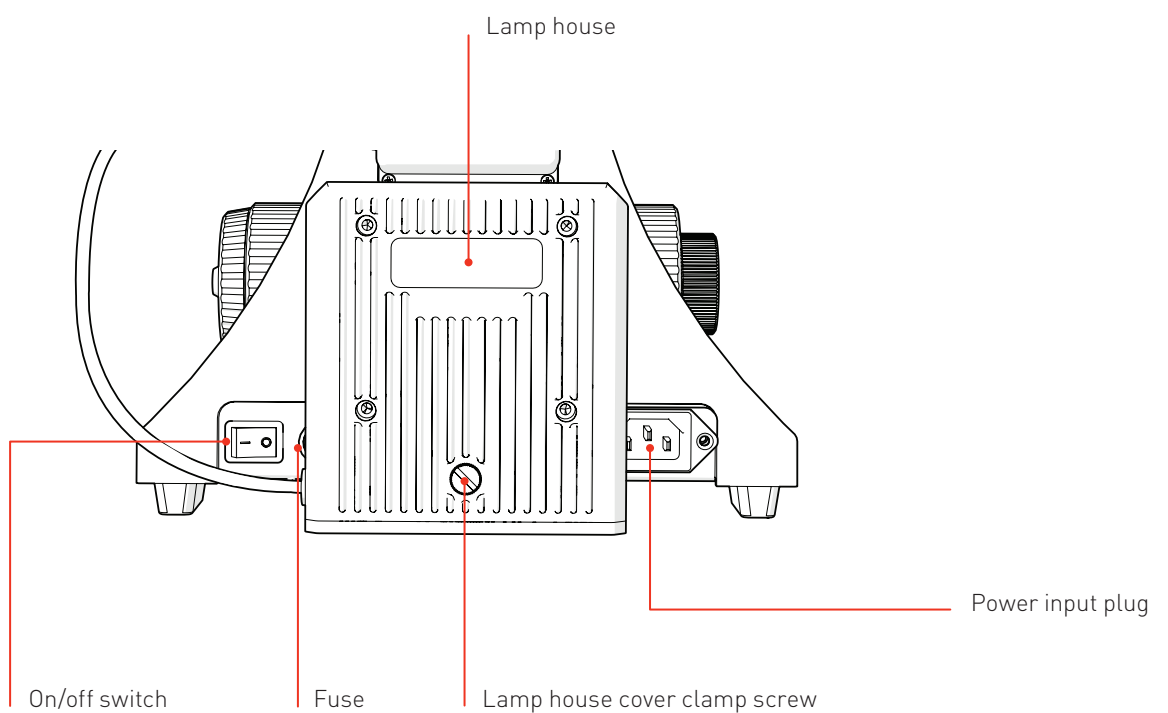
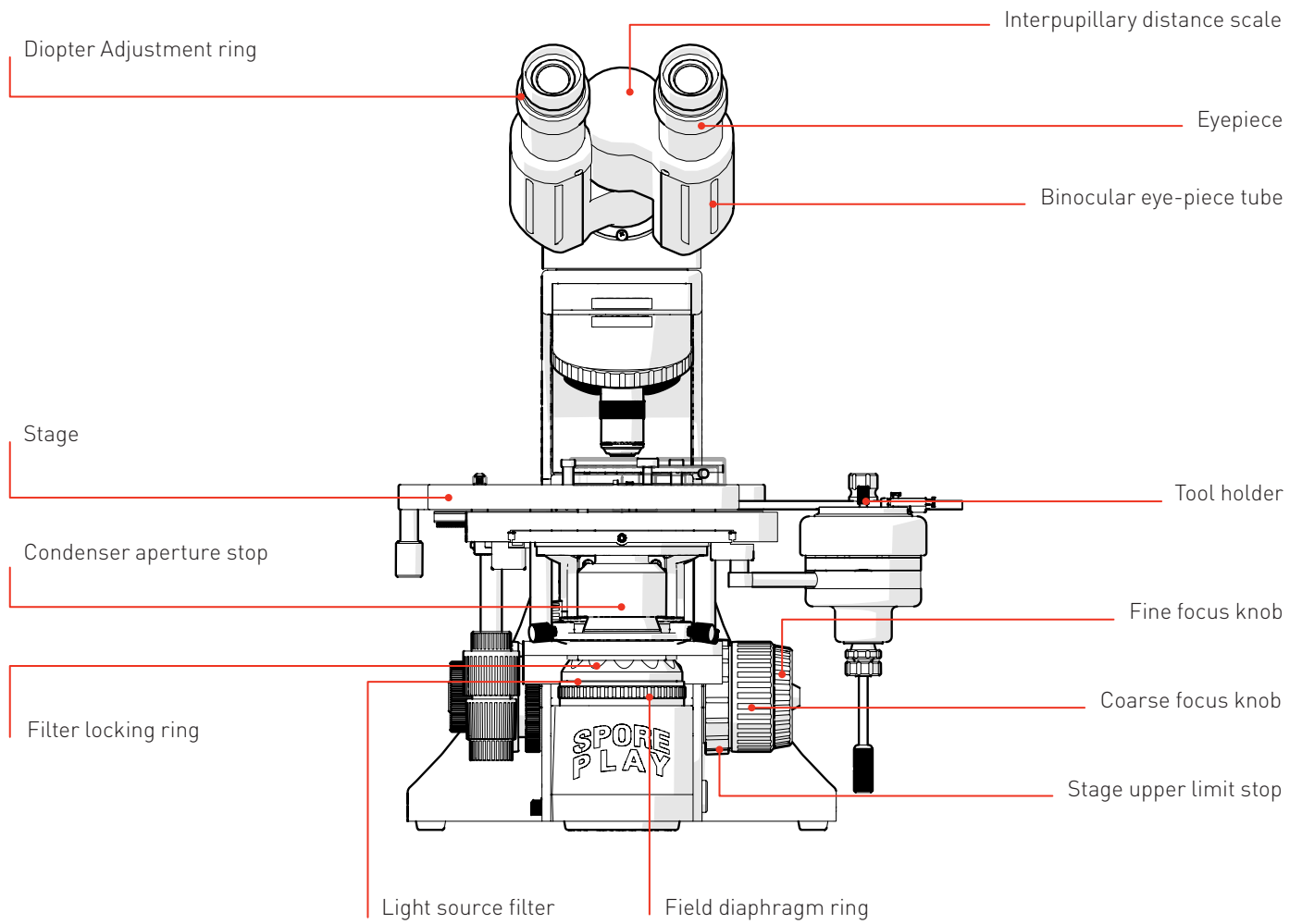

**ANATOMY & FEATURES**

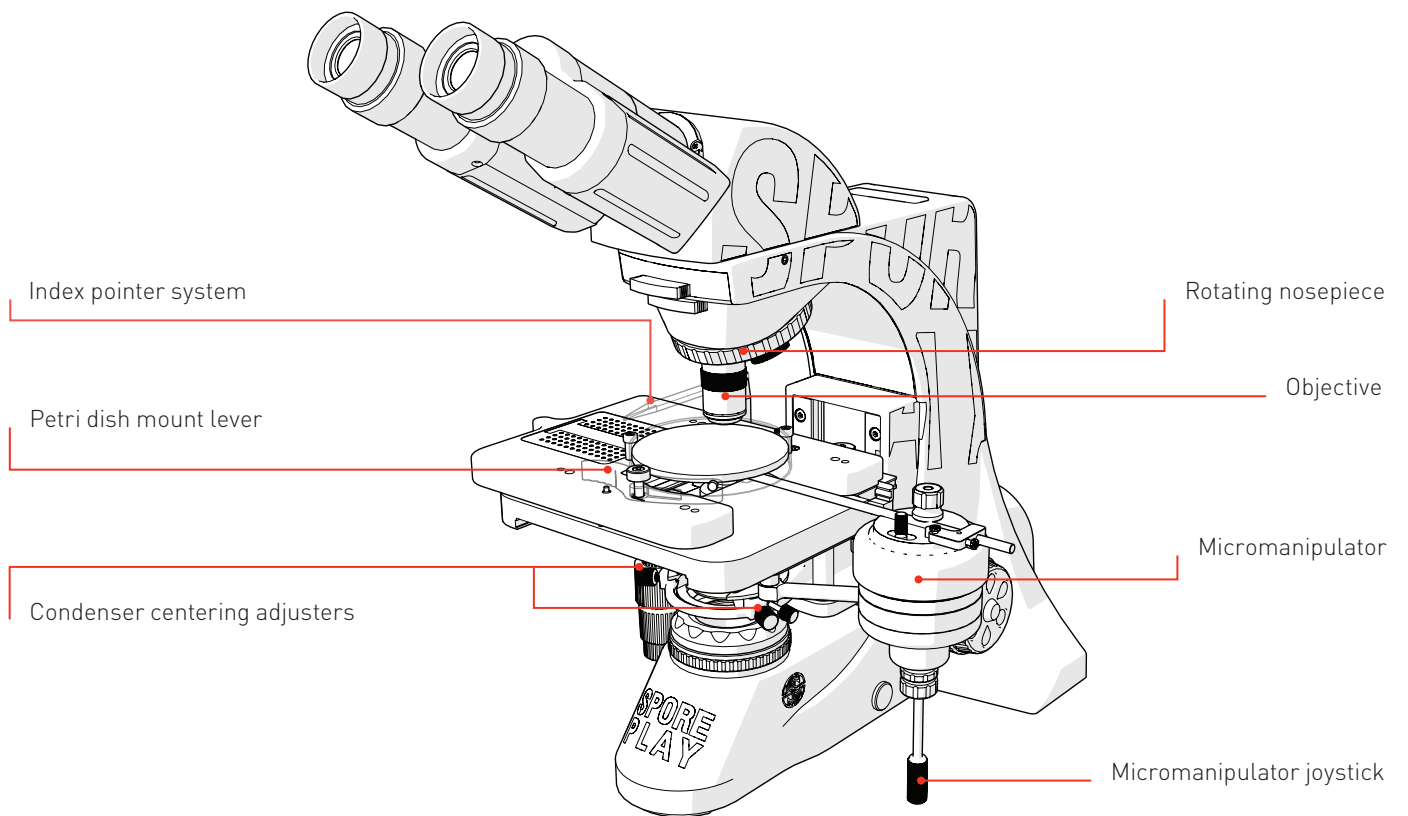
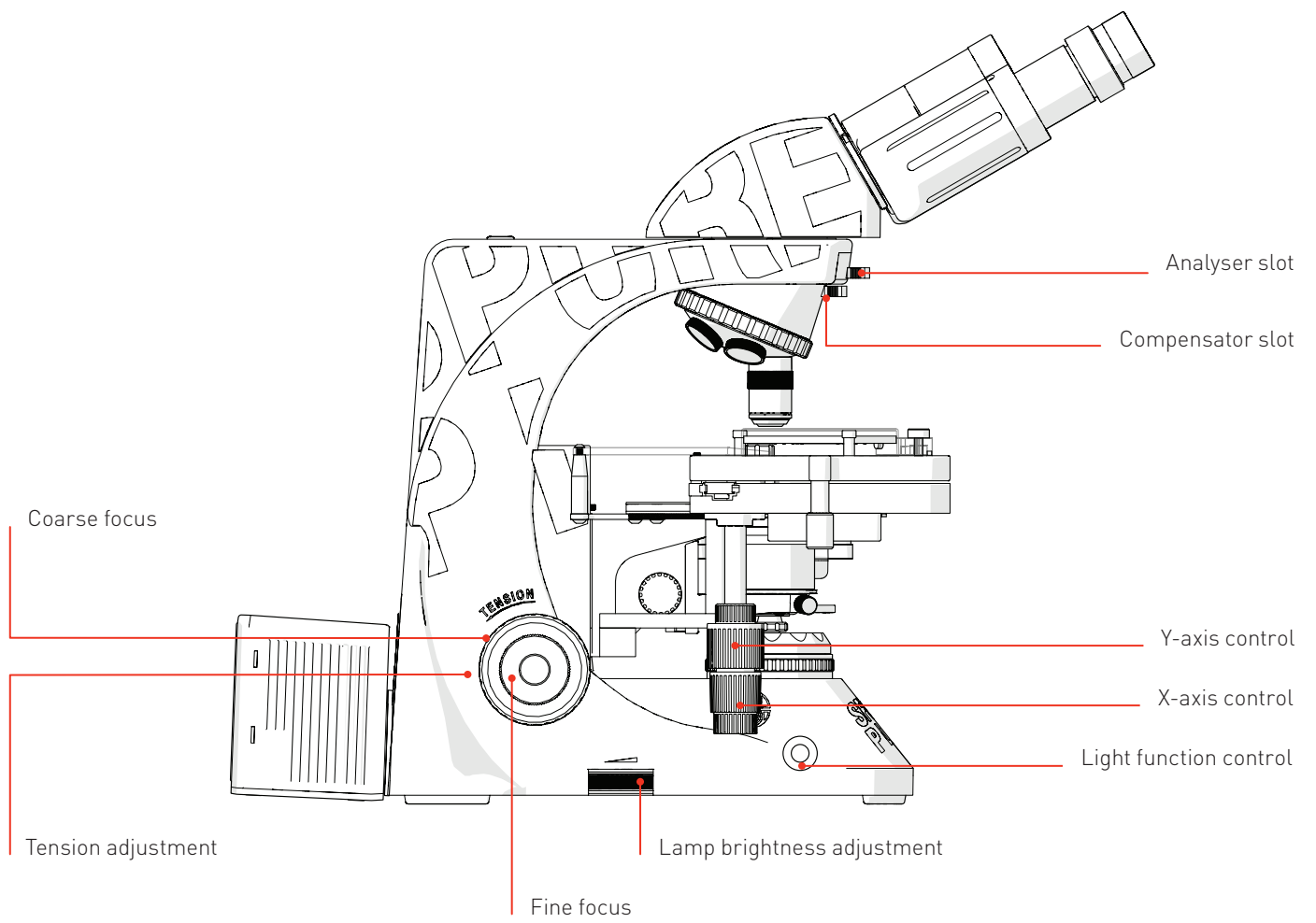

## BASIC FUNCTIONS

1

### ADJUSTING NOSEPIECE

The nosepiece can rotate 360° and houses up to 5 objectives.

**NOTE:** If using the Auto Light Function in step 4, there will be a slight light delay when switching between objectives.

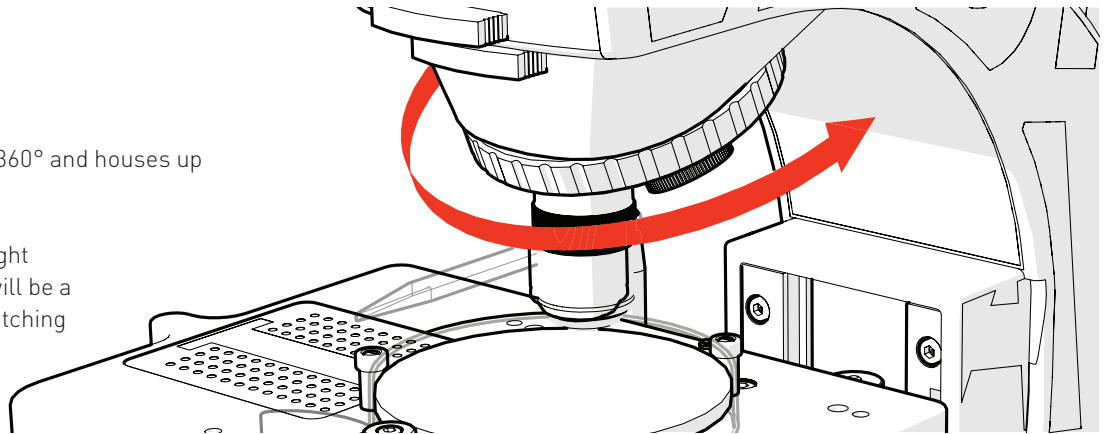

2

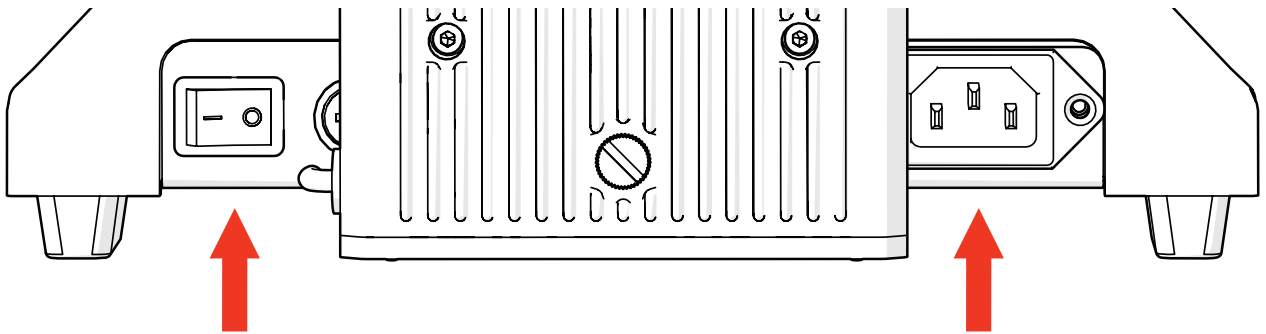

### POWERING UP

Plug in and turn on with the power switch at rear. Check fuse and lamp if nothing happens.

3

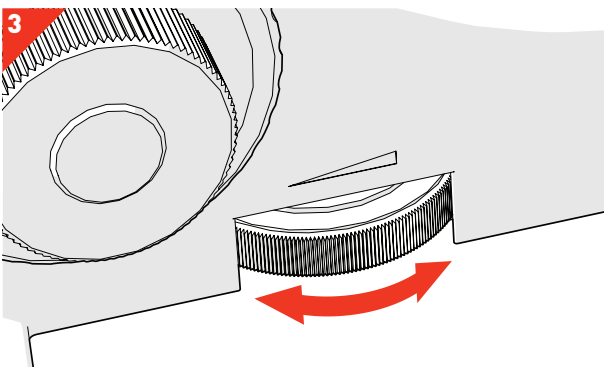

### ADJUST LAMP BRIGHTNESS

The SporePlay+ lamp automatically adapts the light intensity in relation to the chosen objective. This information is stored for future use. However, if a brighter light is required, turn dial clockwise, likewise, turn anticlockwise to dim.

4

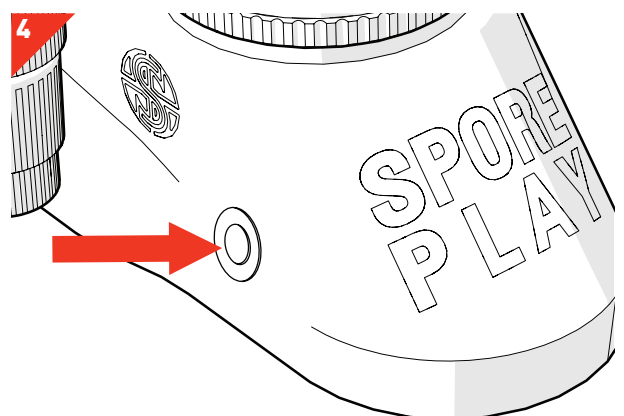

### AUTO LIGHT FUNCTION

When the light function control button is pressed, the SporePlay+ will automatically turn off after 15 minutes of not detecting any movement. The SporePlay+ will turn back on when movement is detected.

**NOTE:** Using this function will cause a slight light delay when switching between objectives.

## STAGE & INDEX POINTER SYSTEM

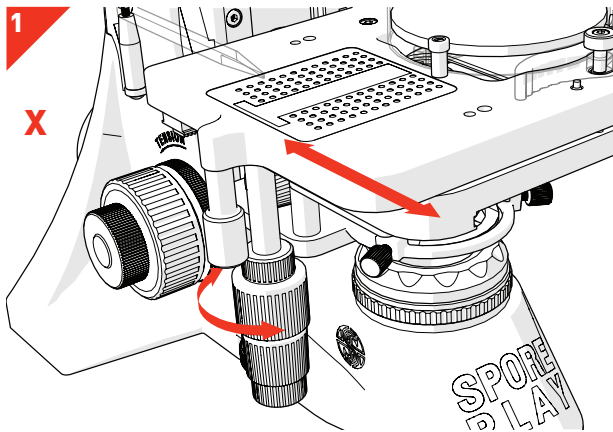

### X, Y & Z AXIS ADJUSTMENT

The stage can be moved across the X and Y Axes in 5mm increments.

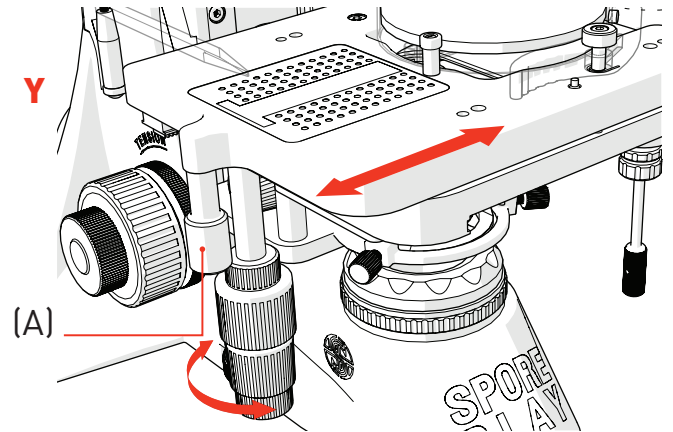

Use the Pendant Handle (A) to move the stage more rapidly if larger movements are required.

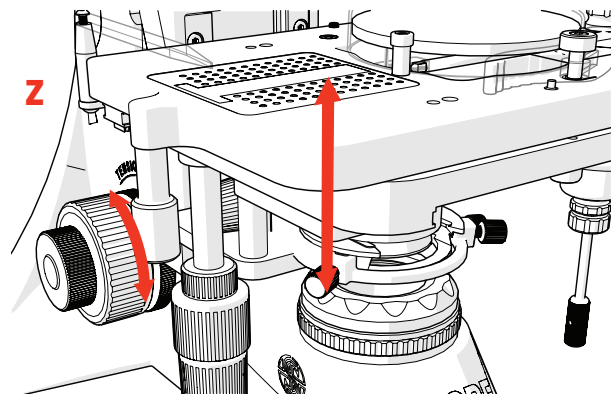

The Z axis has a total working distance of 27mm with a fixed upper limit stop for lens protection.

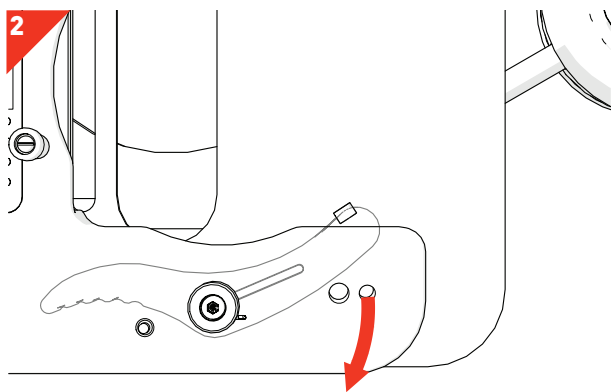

### PETRI DISH MOUNT

The sprung lever ensures the fixed position of the petri dish during analysis.

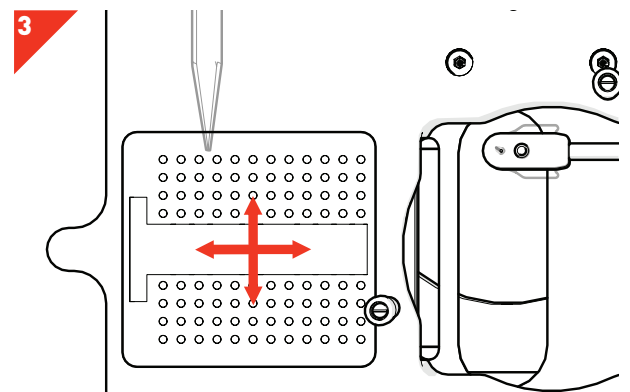

### INDEX POINTER SYSTEM

This intuitive addition aids ease-of-use and reduces user error. It points to a graphical representation of the dissection layout as a positional reminder during stage translation.

## MICROMANIPULATOR & NEEDLE HOLDER

1

### UNLOCK/LOCK MECHANISM

The micromanipulator comes with a unique twist-lock mechanism. Unscrew the counter-rotating joystick locking collars and slide downwards. Re-lock after use.

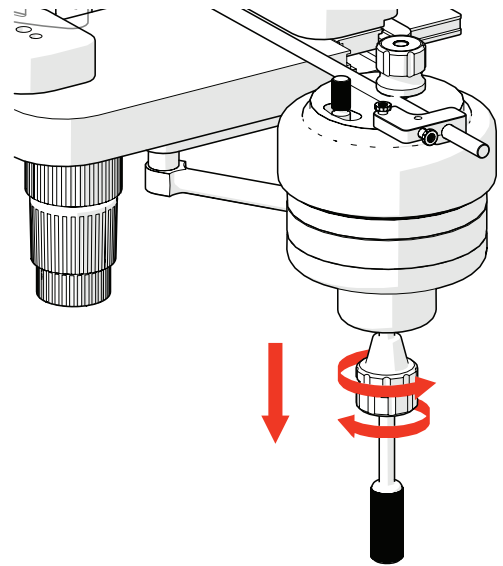

2

### X, Y & Z AXIS JOYSTICK CONTROL

The joystick has 360° rotation and mimics the movement of the hand at a ratio of 25:1 (X&Y Axes). If less movement is required of the joystick, the locking collars can be adjusted to limit the joystick's range of movement.

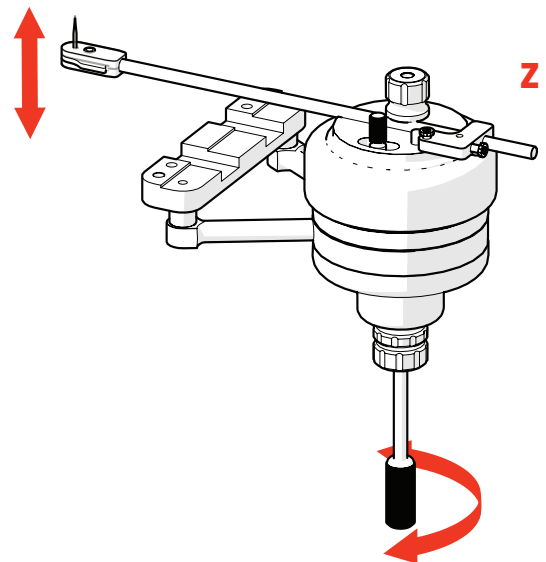
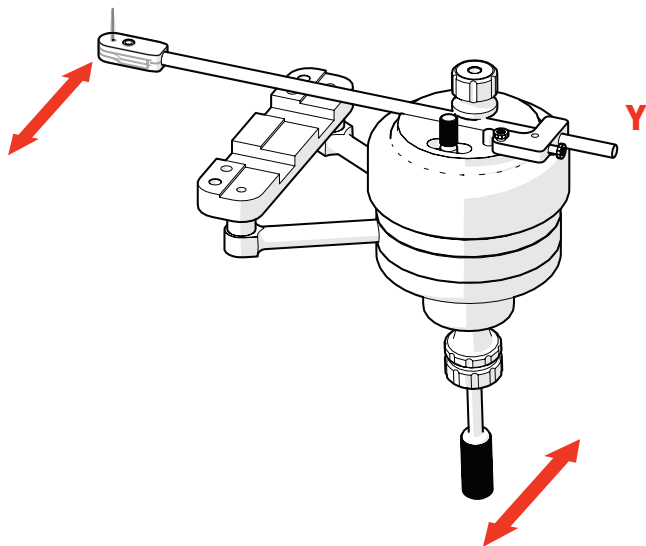
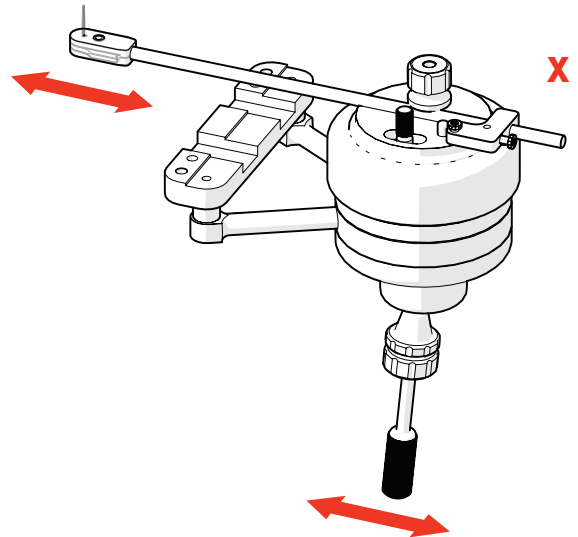



## MICROMANIPULATOR & NEEDLE HOLDER

3

### TOOL HOLDER CLAMP

The tool holder stop secures the tool holder in place and can be undone to make needle replacement quick and easy.

NOTE: When using the SporePlay+ for applications not requiring a dissection needle, removing the tool holder will improve lighting conditions.

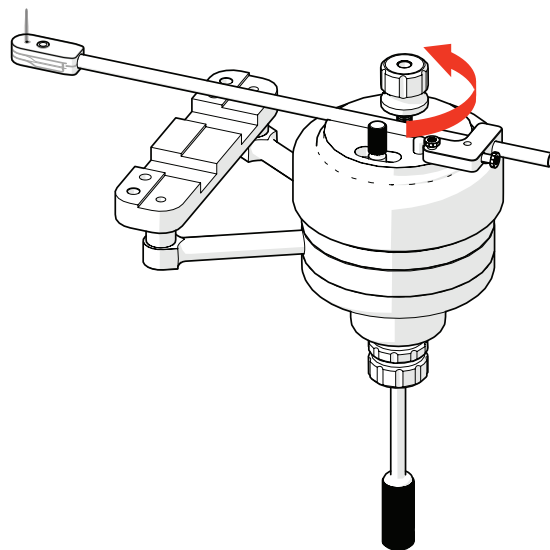

4

### Y AXIS CONTROL LOCK

This handy feature allows the user to make fine adjustment to the position of the needle across the Y axis.

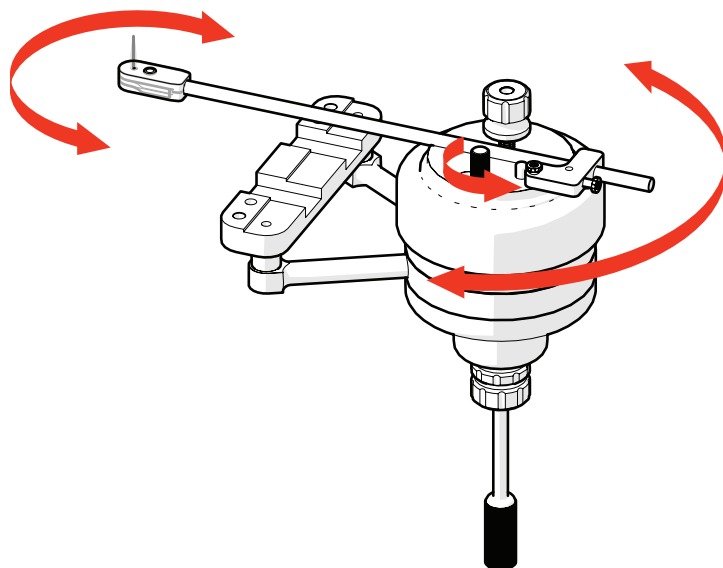

5

### PINCH-RELEASE NEEDLE HOLDER

Applying pressure to the wings of the needle holder will release the needle, whilst removing the pressure will clamp it in place.

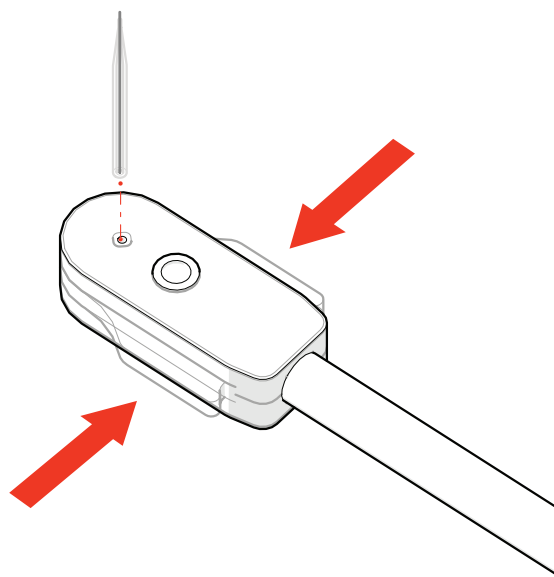

### MAINTAINING YOUR SPOREPLAY+

Cover when not in use and keep clean.

CAUTION: DO NOT USE SOLVENTS.

## CHANGING THE FILTER

### LIGHT SOURCE FILTER

Included with the SporePlay+ is an extra Light Source Filter. Fitting this is optional but may be used to reduce the light intensity. The optional, 45mm diameter filter offers a more yellow light to soothe the eye. This could be desirable if using the SporePlay+ for long periods of time.

For information about alternative filters available contact: [sales@singerinstruments.com](mailto:sales@singerinstruments.com)

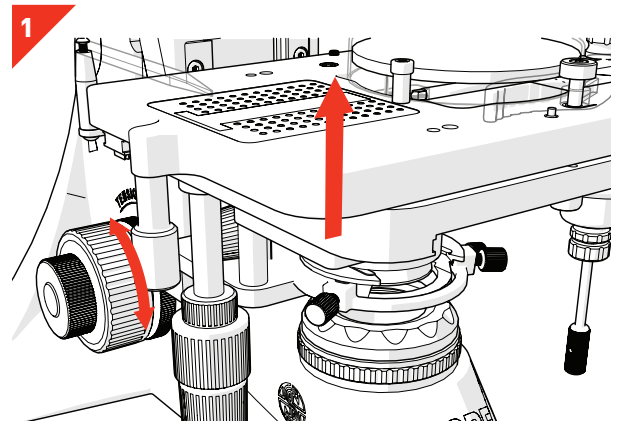

Raise the Stage up to give yourself some room.

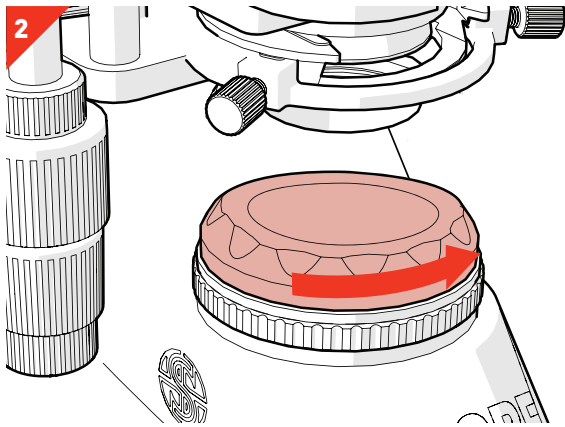

Rotate the Locking Ring anti-clockwise and remove.

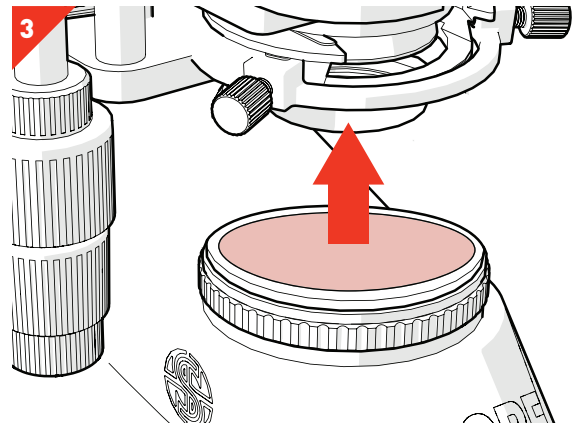

Remove the existing filter and replace it with your desired filter.

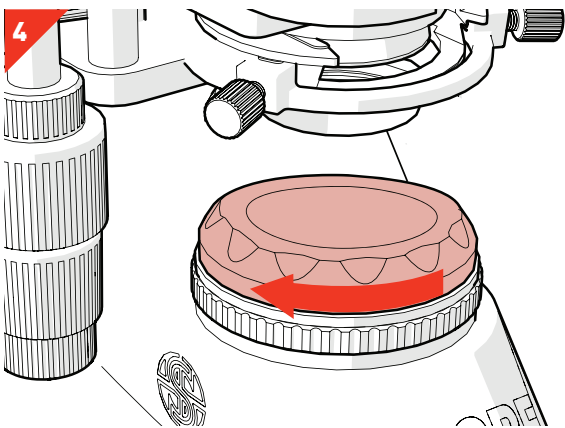

Re-attach and tighten the Locking Ring.

## CHANGING THE CONDENSER

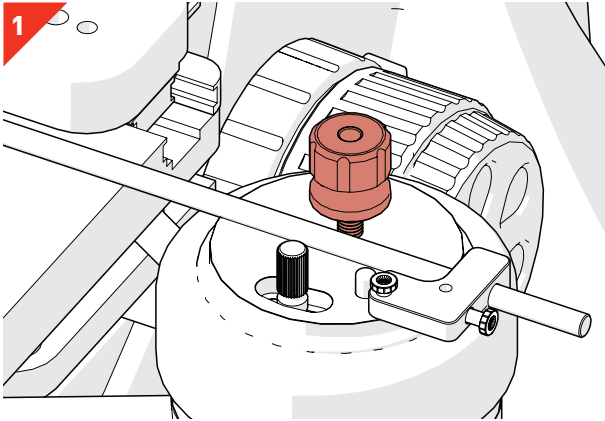

1. Loosen the Micromanipulator Knob and remove the Needle Holder.

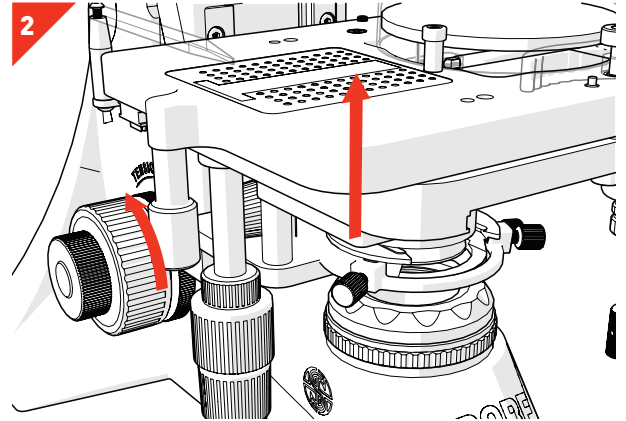

1. Raise the Stage to its highest position.

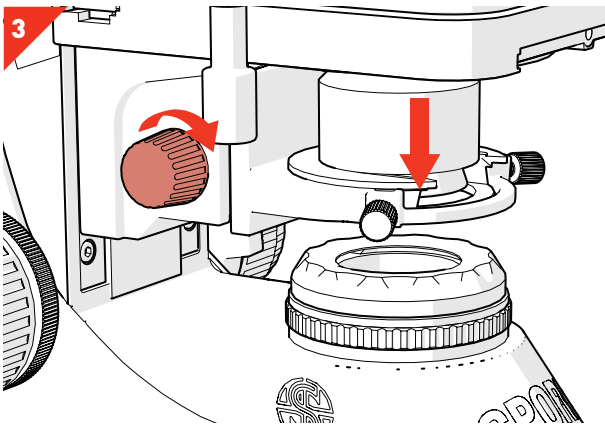

1. Lower the Condenser to its lowest position using the Condenser Height Knob.

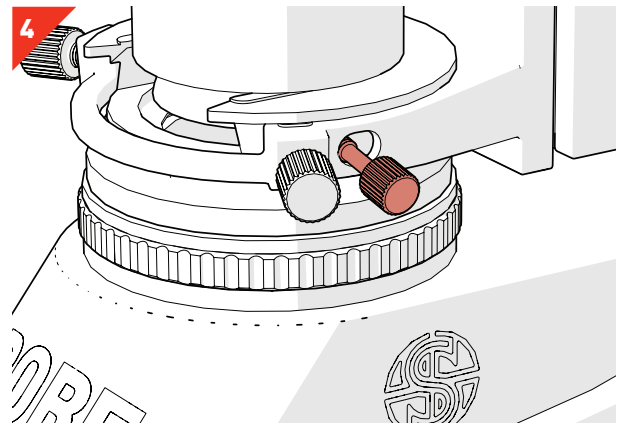

1. Unscrew the Condenser Locking Screw.



1. Remove the existing Condenser.

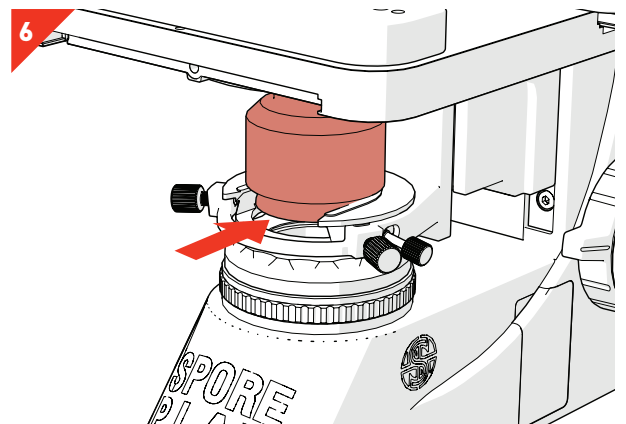

1. Slide in the new Condenser.  
2. Now tighten the Condenser Locking Screw; reset the Condenser and Stage heights; and re-attach the Tool Holder. Good to go!

## MARKING THE DISH

There are two areas you can mark the position of the inoculum:  
A) Through the centre of the plate; or B) On the left. Place the plate over the template below and mark the positions with a lab pen.

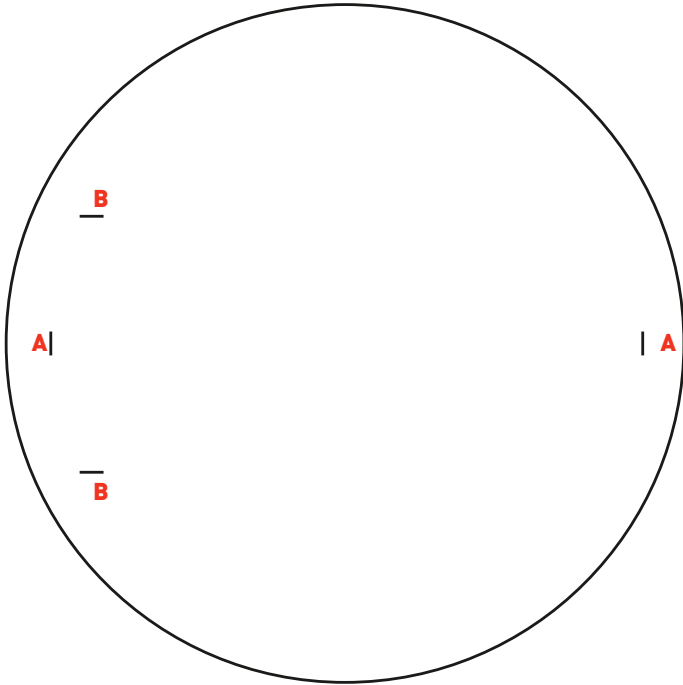

Choose inoculum position A or B and with a *3mm Flamed Loop*, inoculate the dish between the two marks as shown below.

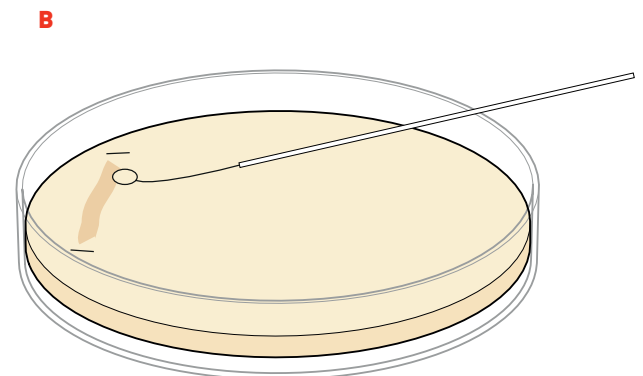
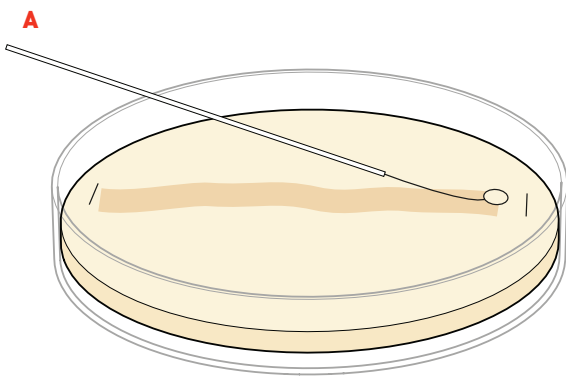

When taking the dish out of the SporePlay+ it is useful to have some way of orientating the plate. Marking it either at the Rear Post or the Lever Pad will help to position the dish when returning it.

Rear post

Lever pad

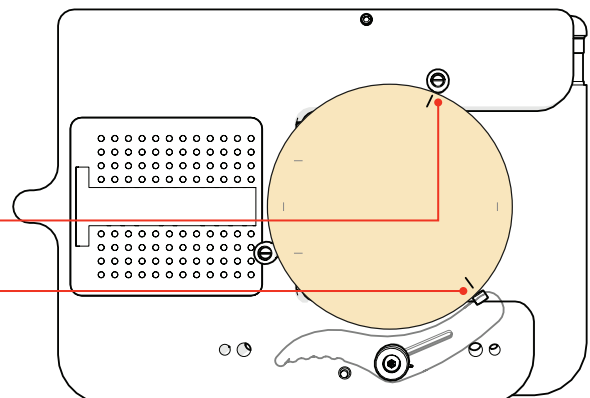

## TROUBLESHOOTING

### THE IMAGE IS BLURRED AND IT'S DIFFICULT TO SEE THE TETRADS.

1. If the plate has just been removed from the refrigerator then condensation can form on the plate. Allow it to warm to room temperature and gently wipe the top of the plate with a suitable paper towel.
2. Also with a lens tissue, wipe the bottom of the objective in case condensation has formed there.
3. You could be looking through a lab pen mark used to denote the inoculum area bounds.

### I CAN SEE TETRADS BUT THERE ARE DEEP RINGS AROUND THE SPORES AND OTHER CELLS ON THE PLATE.

If you have just inoculated the plate, particularly if using the drip and run method using a pipetman or similar, then the inoculum will be very wet. Allow the plate to dry at room temperature before proceeding.

### WHEN THE NEEDLE TOUCHES THE AGAR THE CELLS SCATTER AND THERE IS MOVEMENT.

The plate is too wet. Allow at least 1/2 an hour at room temperature for the water to evaporate or be absorbed by the agar.

### I CAN'T SEE A CLEAR IMAGE AND I'M GETTING A HEADACHE EACH TIME I LOOK DOWN THE MICROSCOPE.

1. Be sure that both eyepieces are pushed completely home as they may be slightly tight.
2. Ensure the eyepieces are the correct distance for the eyes.
3. Focus the eyepieces one at a time and don't assume they will be correct immediately. Do this when the needle has been centred and use the needle tip to ensure the eyepieces are par focalised.

### DOES THE SPOREPLAY+ HAVE KOEHLER ILLUMINATION?

The SporePlay+ does not have Koehler illumination. To keep costs to a minimum and so that the condenser can fit under the modified stage a special unit has been designed that will give as flat an illumination as is possible and necessary for tetrad dissection. We are using the same objectives in the SporePlay+ that are in the MSM 400 and have used for 20+ years, however the image quality will always be compromised by the needle, needle holder, agar thickness and clarity.

### THE LIGHTING IS DELAYED WHEN SWITCHING BETWEEN OBJECTIVES.

Using the Automatic Light Function will cause a delay to the lighting when switching between objectives. Turning the Automatic Light Function off will remove this delay.



Lined writing area consisting of 25 horizontal lines.



# SINGER INSTRUMENTS

A RESPONSIBILITY TO SCIENCE!

Roadwater,  
Watchet,  
Somerset.  
TA23 0RE

+44 (0)1984 640226 (tel)

+44 (0)1984 641166 (fax)

[contact@singerinstruments.com](mailto:contact@singerinstruments.com)  
[singerinstruments.com](http://singerinstruments.com)



**SCAN TO VISIT WEBSITE FOR MORE  
HELPFUL TIPS AND TUTORIALS!**



**/SingerInstruments**