

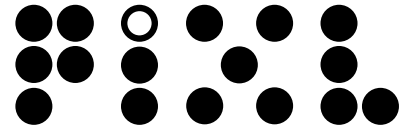

**SINGER
INSTRUMENTS**
A RESPONSIBILITY TO SCIENCE!



DARK

USER GUIDE v1.3

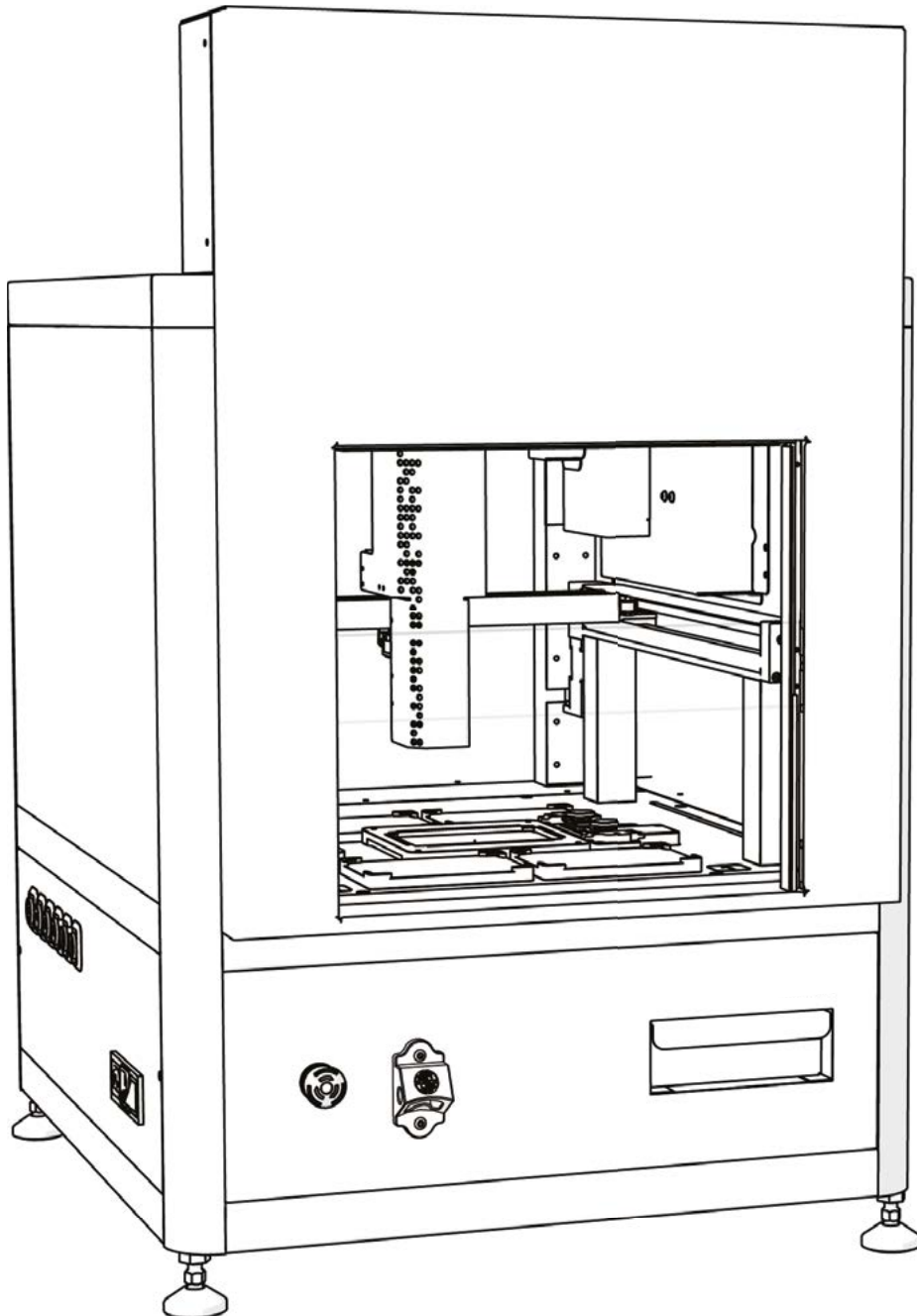

For more support
resources visit
bit.ly/PIXLhelp



READ BEFORE YOU START!

- **The blade is sharp!** Be careful when handling the PIXL blade. Always follow the instructions on page 42 when changing blades.
- **Hand feed the PickupLine™ carefully.** When feeding a PickupLine™ into the machine, if you feel resistance, pull back slightly and re-feed. Forcing the PickupLine™ through will cause damage to the machine.
- **Remove lids when placing plates into the PIXL.** Lids need to be manually removed. Failure to do so will cause damage to the picking arm.
- **The nozzle is hot!** Be careful when removing the nozzle as it can get quite hot.
- **The feed button is disabled.** The feed button is disabled on all PIXL machines. The retract button is fully functional during the change PickupLine maintenance routine.

JOIN OUR DISCOVERY COMMUNITY!

Join our Discovery community and help us to make the product features YOU want.

The Discovery Community is a group of scientists helping us to understand and solve anything causing frustration in their lab.

Help us to shape product development and have a say in future product updates. You'll also get early access to new features and be able to test things before release.

We'll even throw in some cheeky vouchers, Singer discounts and maybe even some cake!

Scan the QR Code or visit bit.ly/CustomerDisco to join.



bit.ly/CustomerDisco

A NOTE ON INSTALLATIONS

We are performing in-person installations again! But for those we can't make it to, never fear! To get you up and running as quickly as possible we have instead included detailed instruction on how to self-install the PIXL (see page 12). We ask that you contact our Tech Support Team to let them know when you're planning to perform the self-installation so they can be on hand should you require any assistance: technicalsupport@singerinstruments.com

Once the installation is complete, please fill-in the online Self-Installation Form: <http://bit.ly/Selfinstallation>

You will be asked to create an account before you start. You can also use this form to report any issues encountered during installation.

NOTE: Completion of this form will activate the start of your warranty period. Failure to complete the form may affect the support we are able to offer during the warranty period.

Thanks for being awesome!

2	Read before you start!	52	Replace nozzle
4	Introduction	53	Calibrate nozzle
5	OUT OF THE BOX	54	Calibrate camera
6	Anatomy & features	55	Clean waste chute
12	Unboxing & assembly	56	Change UV bulb
17	DOOR CONTROLS	57	BEST PRACTICE
18	Door control overview	58	Plates
19	RANDOM COLONY PICKING	59	Cleaning
20	Random colony picking overview	60	Project templates
30	RE-ARRAY	61	Pinning and mixing profiles
31	Re-array overview	62	Help - See how videos
34	COLONY DETECTION	63	Software icons
35	Colony detection overview	66	Troubleshooting
40	PICKING TO MALDI-TOF SLIDES	67	Creating a Re-array file
41	Picking to Maldi-Tof slides overview	71	Notes
43	FLUORESCENCE		
44	Fluorescence overview		
45	MAINTENANCE MENU		
46	Replace PickupLine™		
51	Change blade		

PIXL™

INTRODUCTION

A super-easy-to-use microbial colony picker. It automates imaging, colony recognition, colony selection, and picking; from Petri dishes to multiwell plates.

The information in this guide relates to software version:
3.24.1125.1

OUT OF THE BOX

Find out what comes with the PIXL. We'll take you through the steps involved in unboxing and assembling ready for picking.

ANATOMY & FEATURES

FRONT

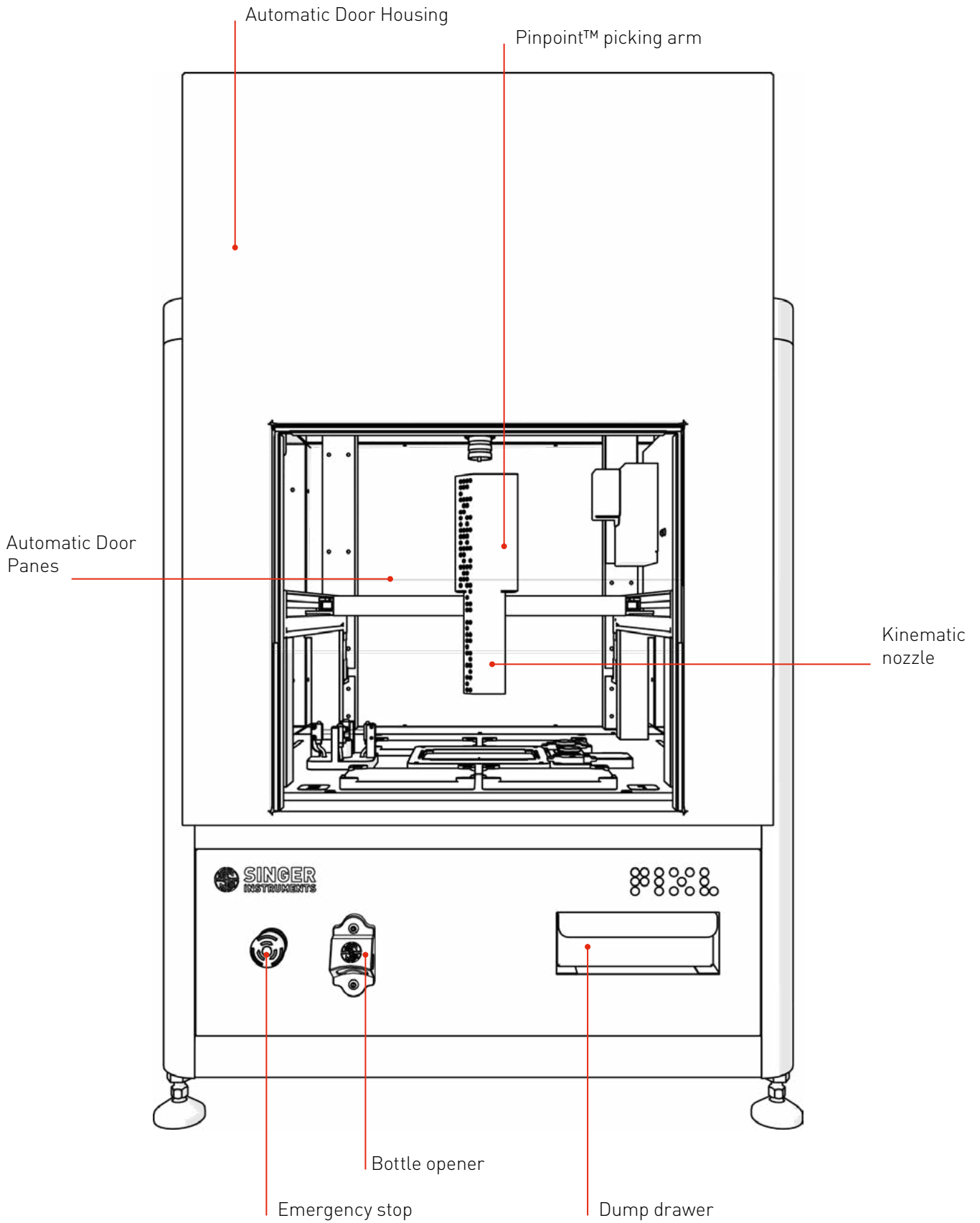

ANATOMY & FEATURES

CAMERA & LIGHTING

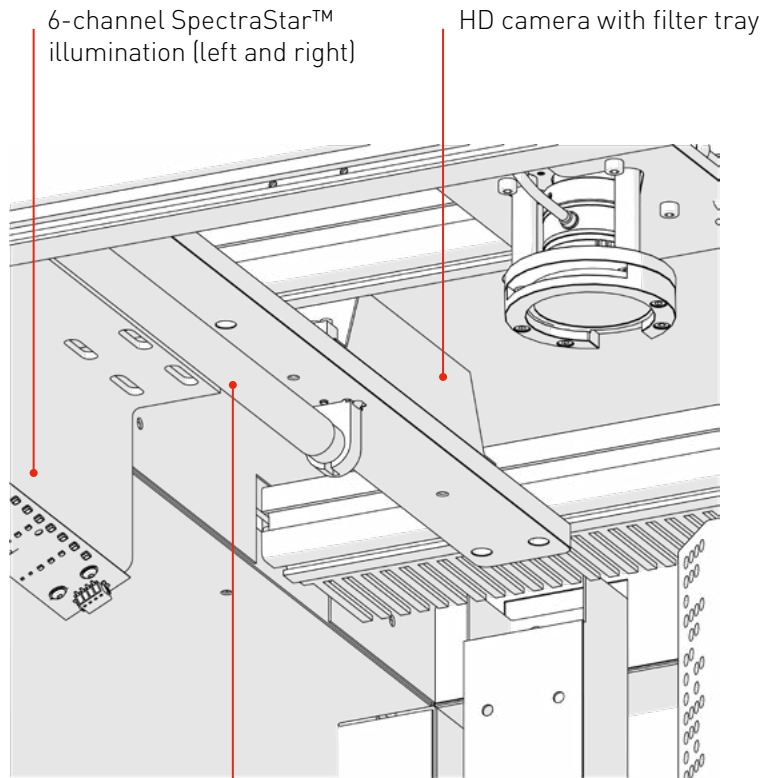
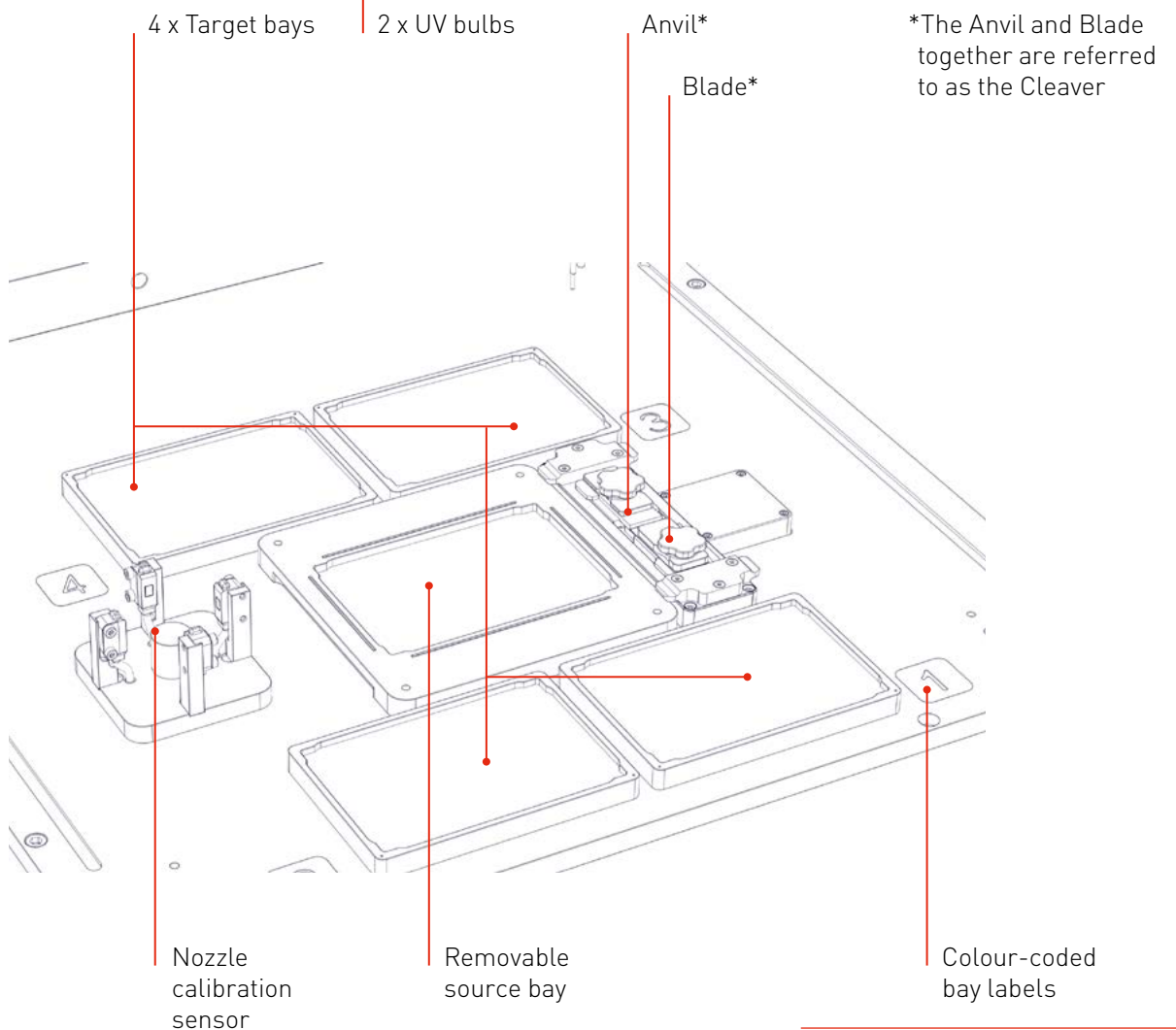

PLATE BAYS



ANATOMY & FEATURES

RIGHT

PickupLine™
compartment

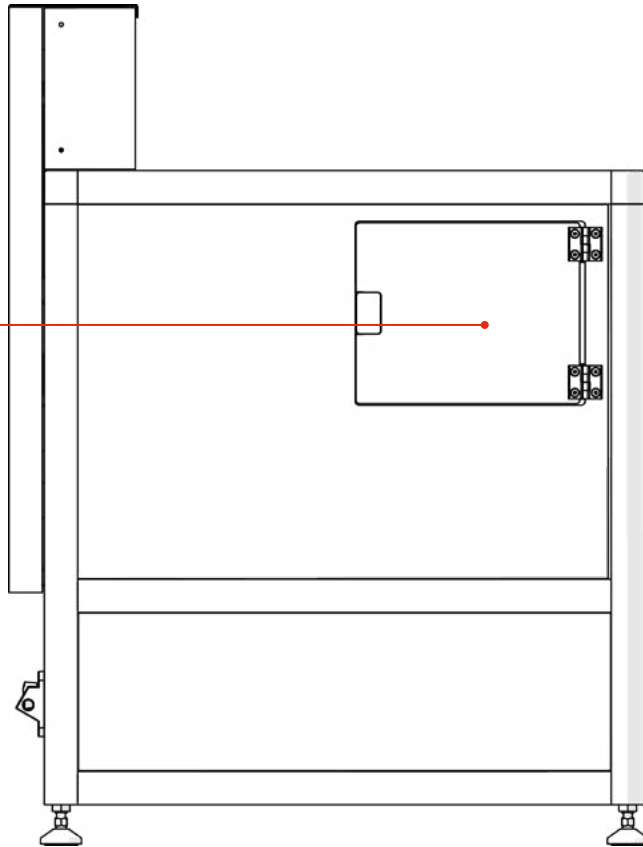

LEFT

Connections:
1 x HDMI
1 x USB 3.0
2 x USB 2.0
1 x RJ45

Power switch

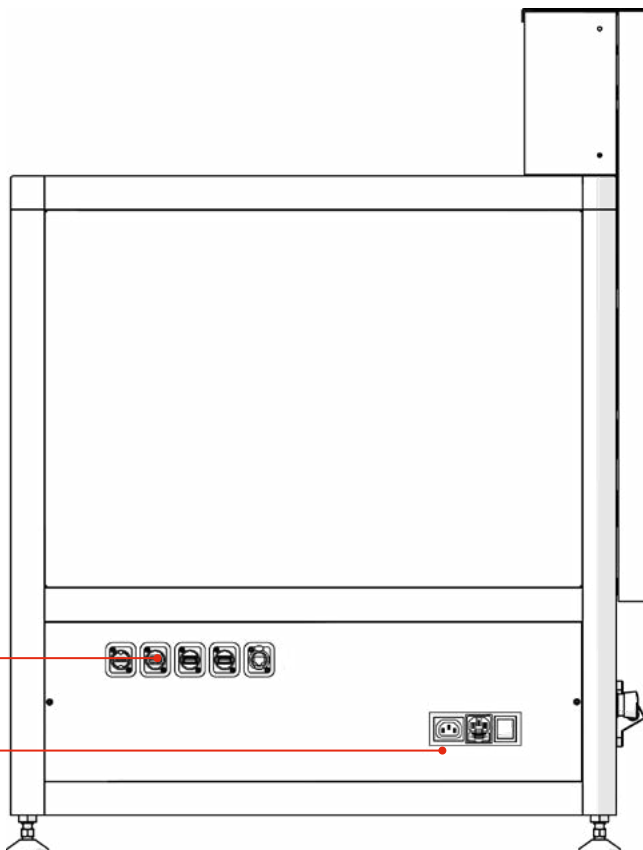

ANATOMY & FEATURES

PICKUPLINE™ COMPARTMENT

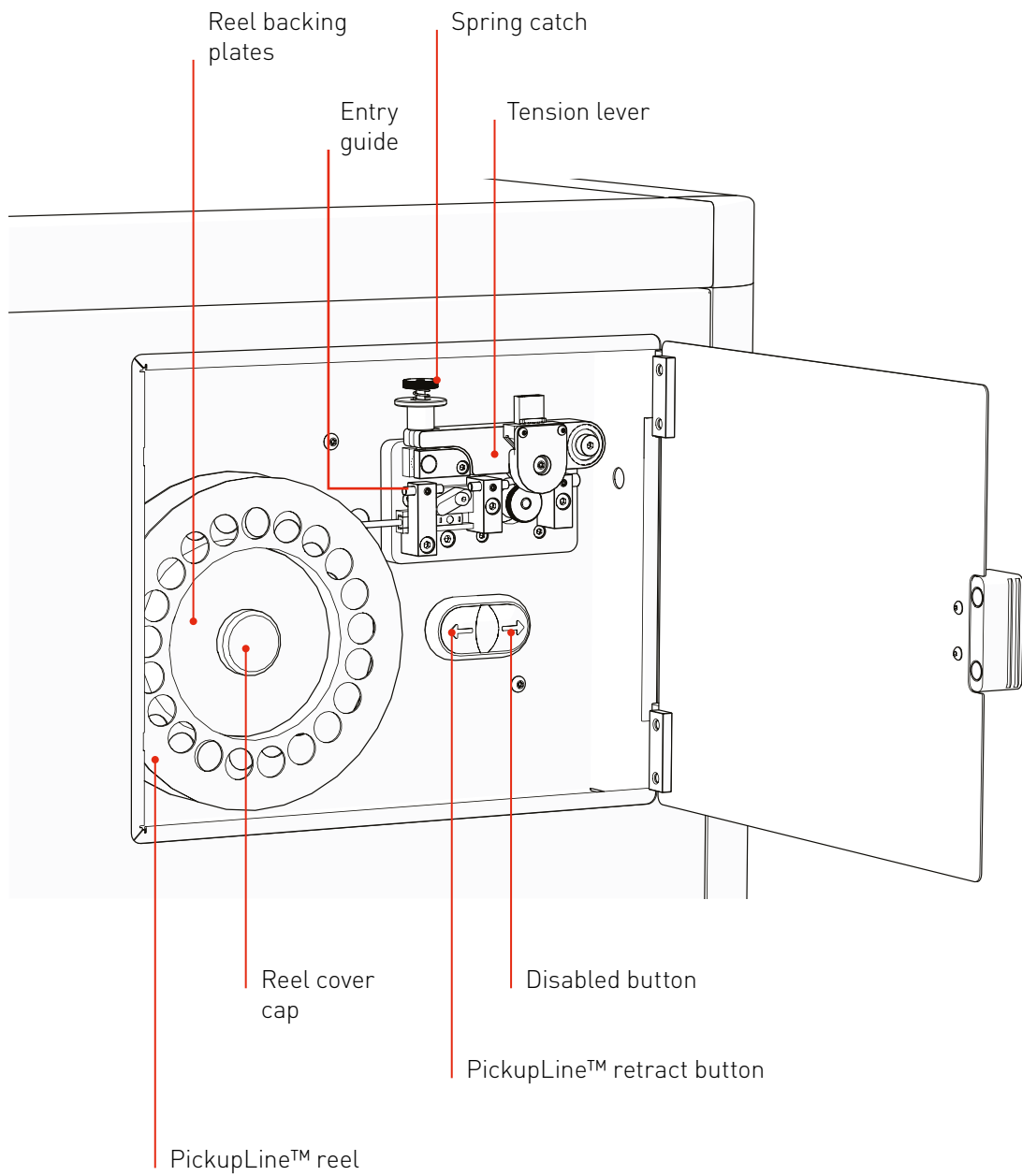

ANATOMY & FEATURES

ACCESSORIES

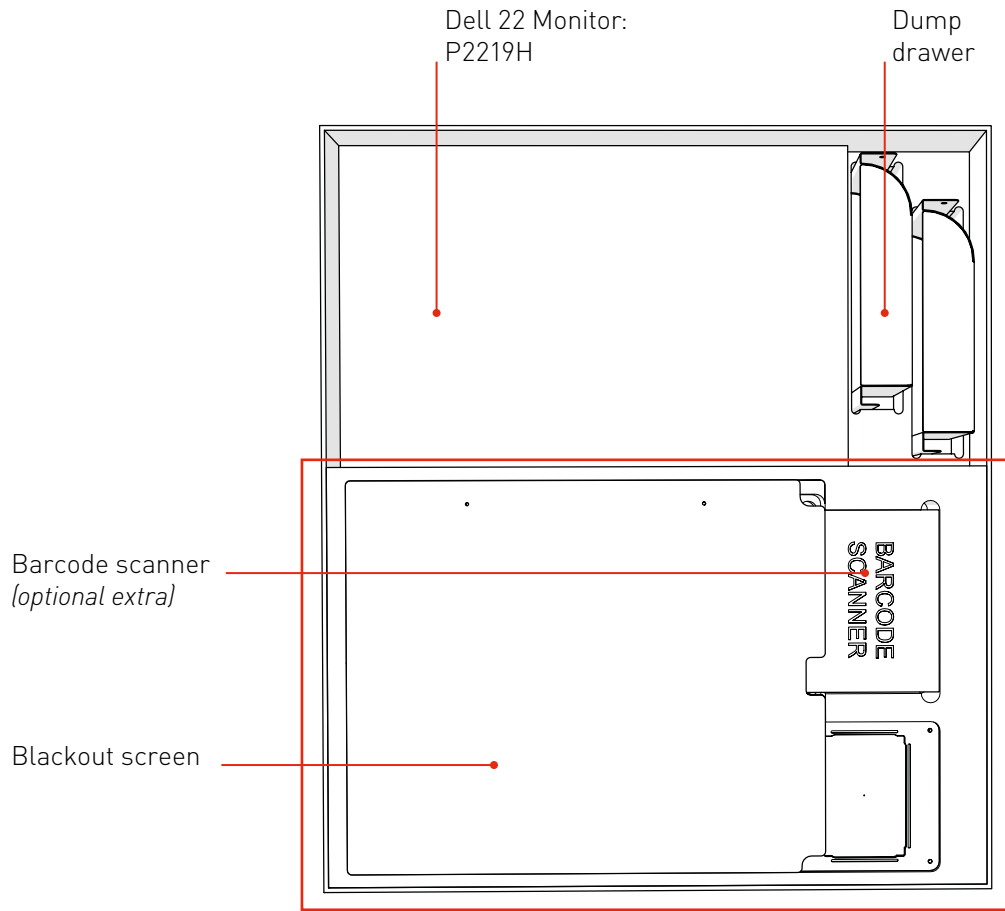

UNDER BLACKOUT SCREEN

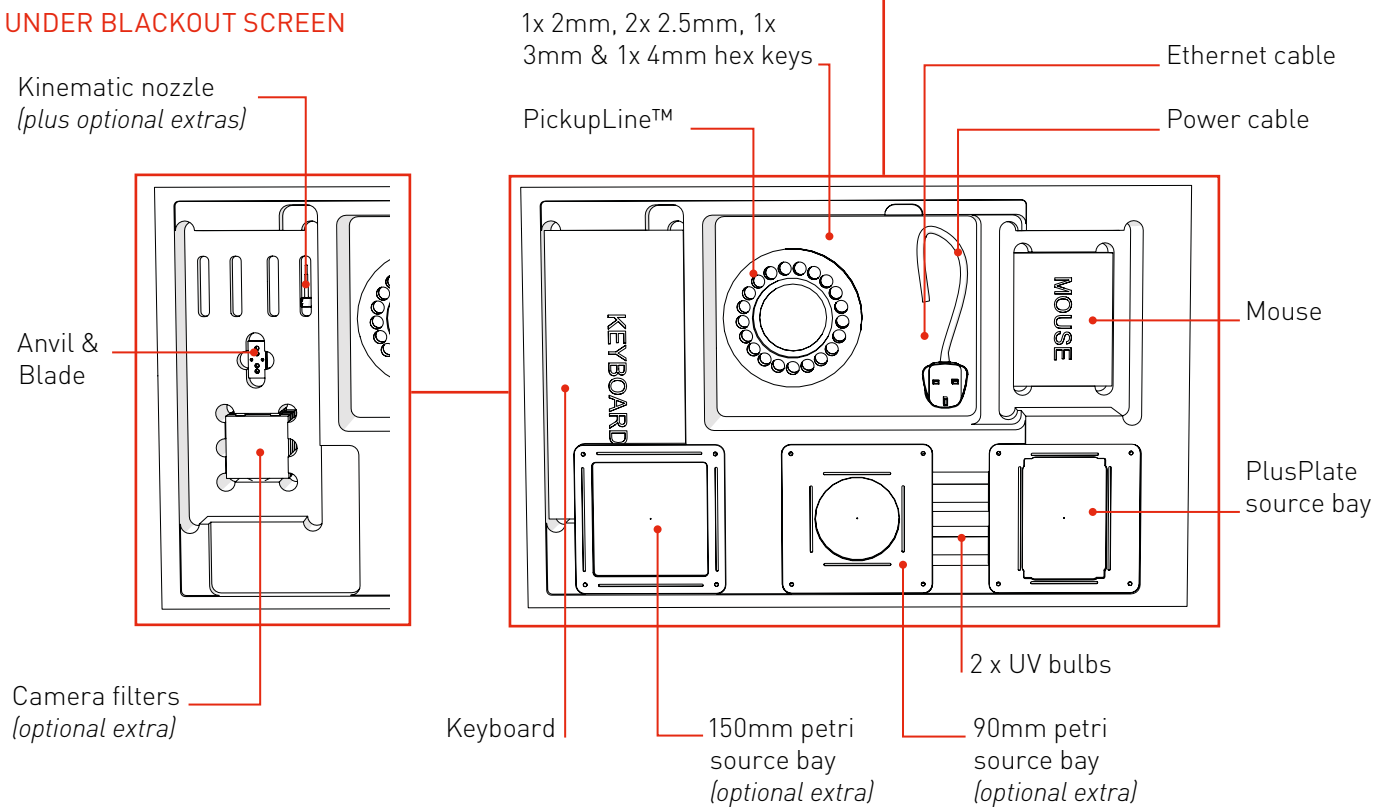

ANATOMY & FEATURES

SOFTWARE

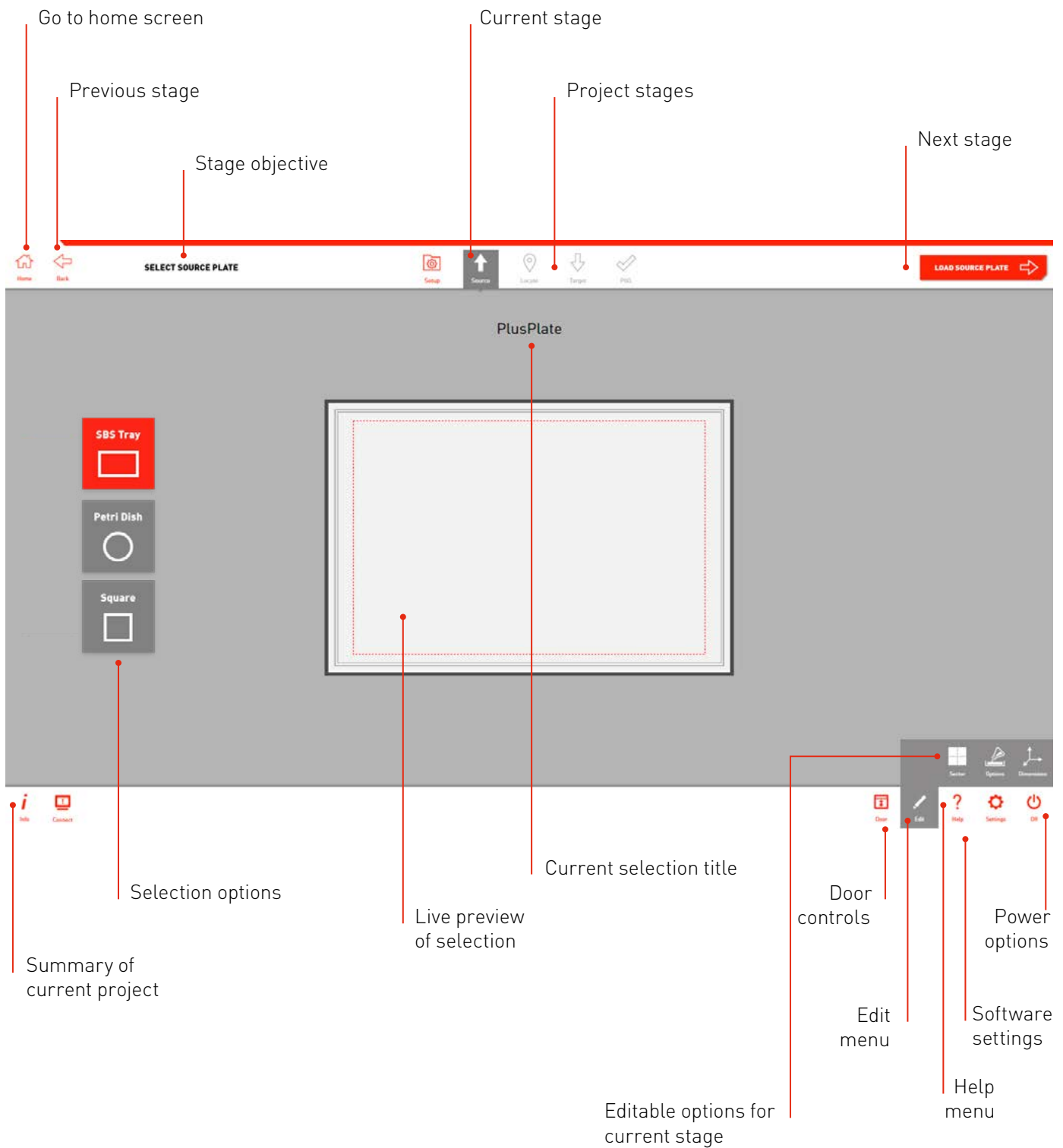

UNBOXING & ASSEMBLY

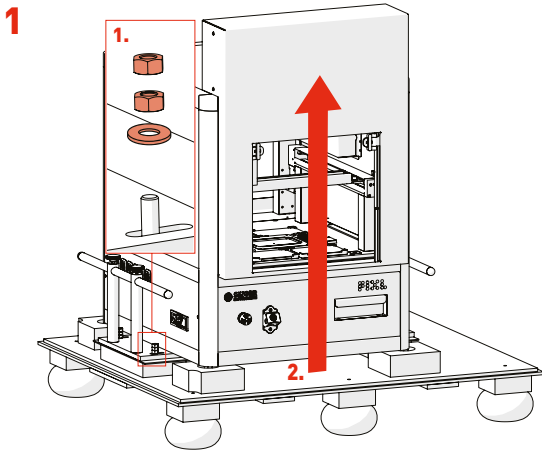

- Remove *Packing Crate Side Panels* and locking nuts (1).
- Carefully lift the PIXL and Place on a sturdy desk (2).
- **HEAVY: Minimum of 4 people recommended**

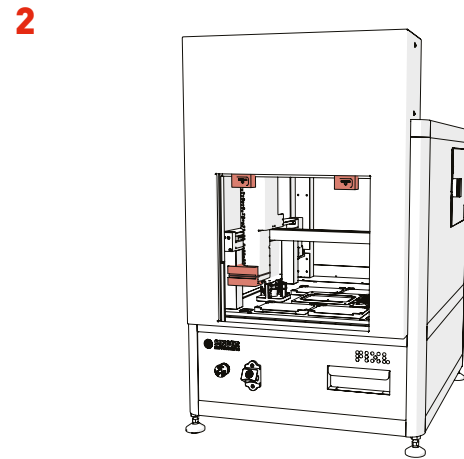

- To remove the *Red Transit Brackets* follow steps 3-5 below.

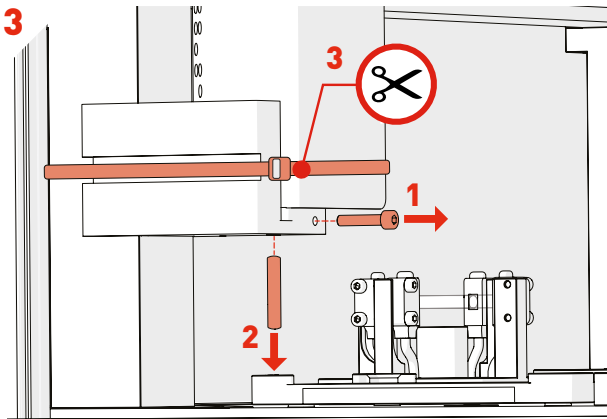

- Use *3mm Hex Key* to undo *Side Screw* (1), then remove *Securing Rod* (2). Cut the cable tie securing the floating head transit bracket with a pair of scissors (3).

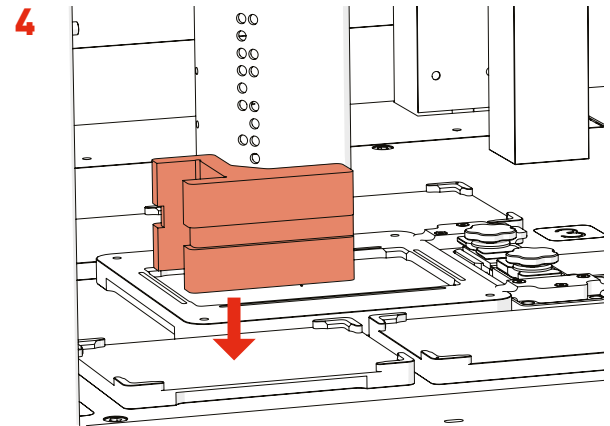

- Position the floating head in the middle of the machine and remove the transit bracket.

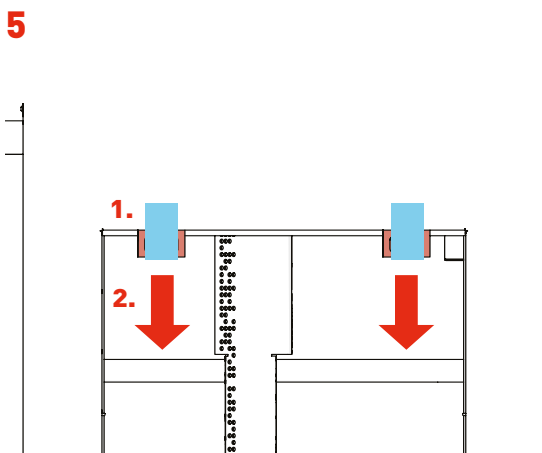

- Remove the blue tape from the *Door transit brackets* (1) Pull both *Door transit brackets* with a downward motion to remove (2).

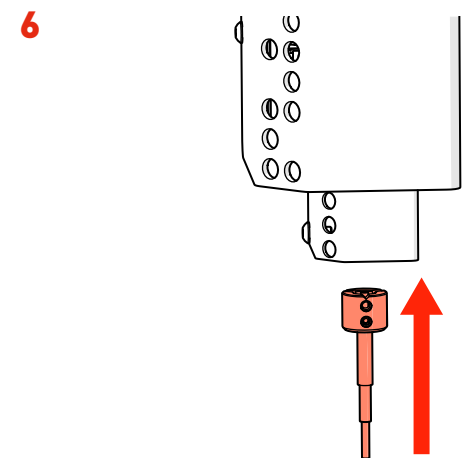

- Attach the *Kinematic Nozzle* onto the securing magnetic ring.
- Ensure the screws are at the front of the nozzle.

UNBOXING & ASSEMBLY

7

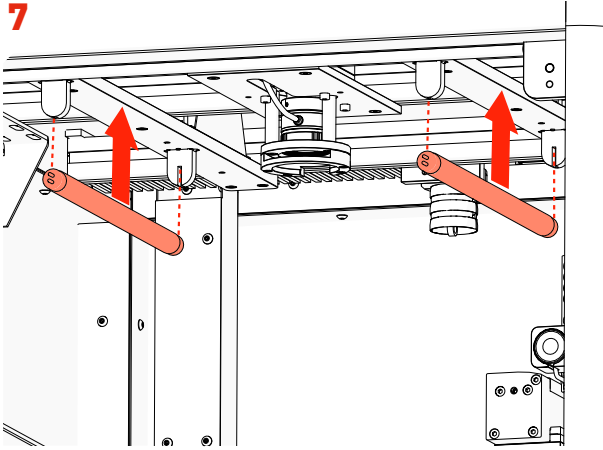

- Remove the 2 *UV Bulbs* from their protective box and slide between the *UV Sockets* attached to the roof of the main cabinet.
- NOTE: Wear gloves.

8

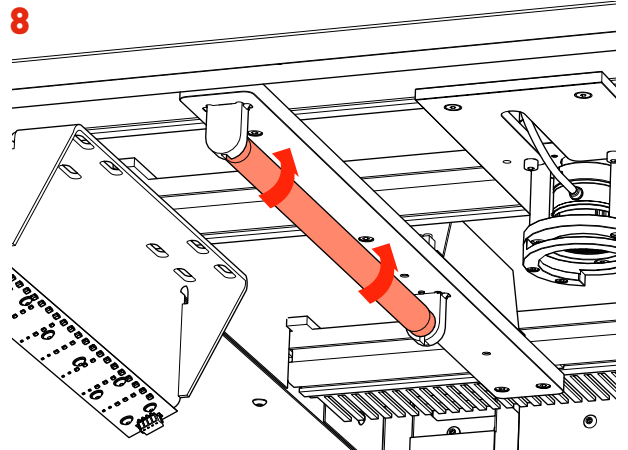

- To lock into place, turn each *UV Bulb* 90 degrees in any direction until you hear a click.

9

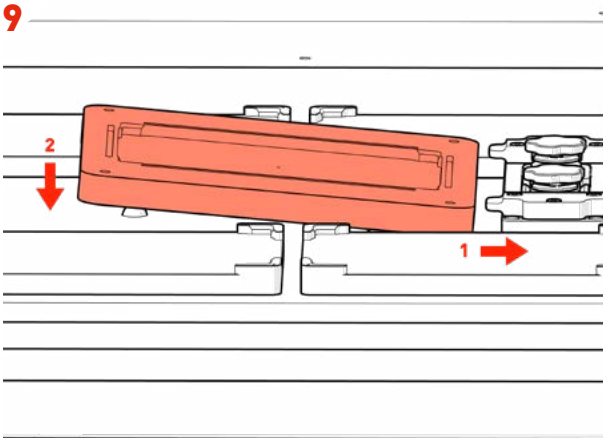

- Install the *Source Bay* by sliding the right side under the *Cleaver Tabs* (1), then lowering the left side onto the magnetic base (2).

10

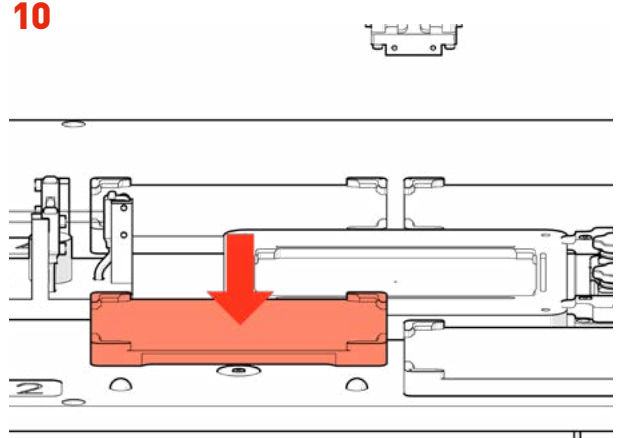

- If you have a Maldi compatible PIXL, install the removeable target bay in the Bay 2 position.

11

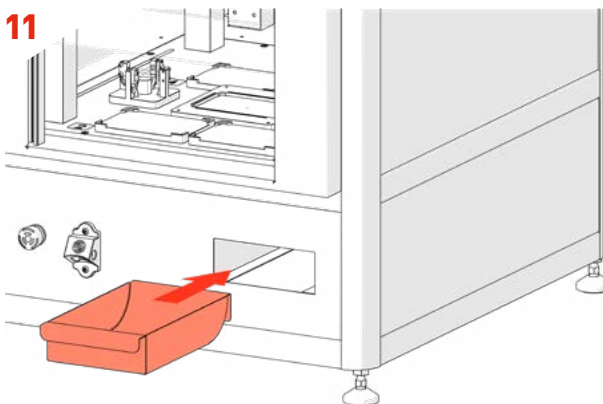

- Ensure the *Dump Drawer* is installed.

12

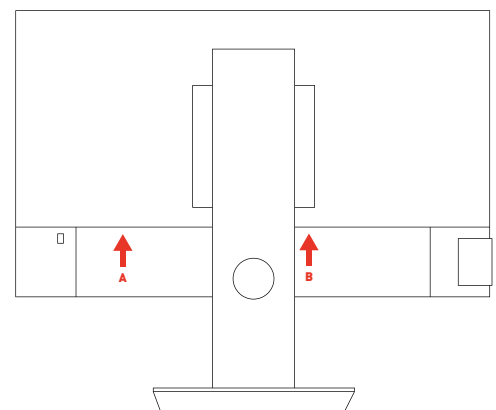

- Plug in the provided Screen cables: *Power (A)* and *HDMI (B)*.

UNBOXING & ASSEMBLY

13

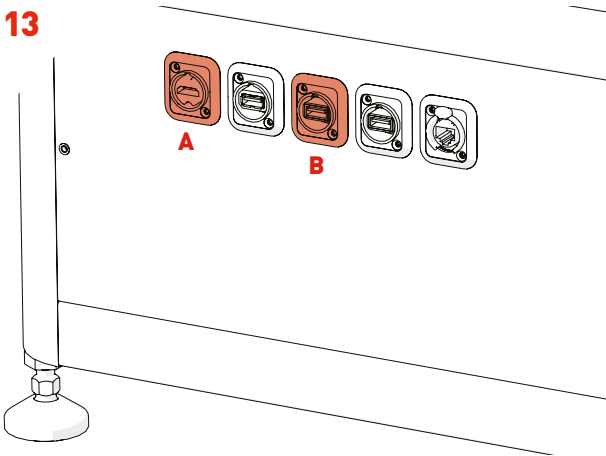

- Connect the Screen to the PIXL: HDMI (A).
- If using the Bluetooth mouse/keyboard, place the Bluetooth dongle into an available USB slot (B).

14

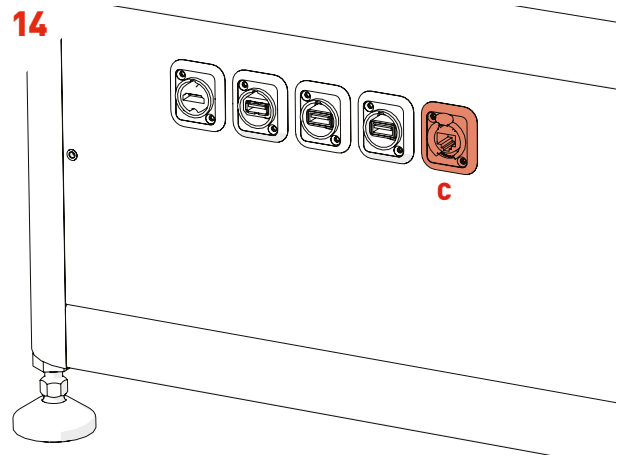

- For internal network access, connect an Ethernet Cable to the RJ45 Socket (C).

15

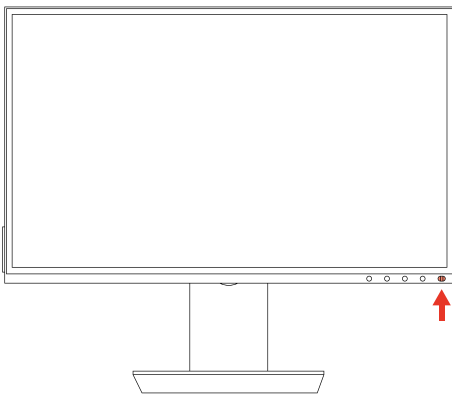

- Turn on the Screen Power Switch.

16

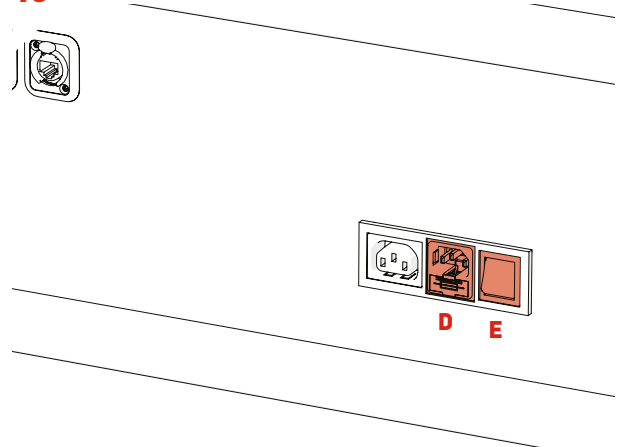

- Plug in the PIXL Power Cable (D) and press the Power Switch (E).
- The Screen will also turn on.

17



- After initialising follow on-screen instructions for PickupLine™ installation.

18

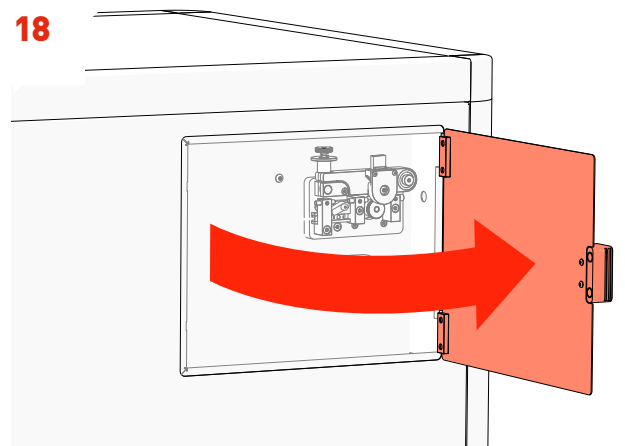

- Open the PickupLine™ Compartment.

UNBOXING & ASSEMBLY

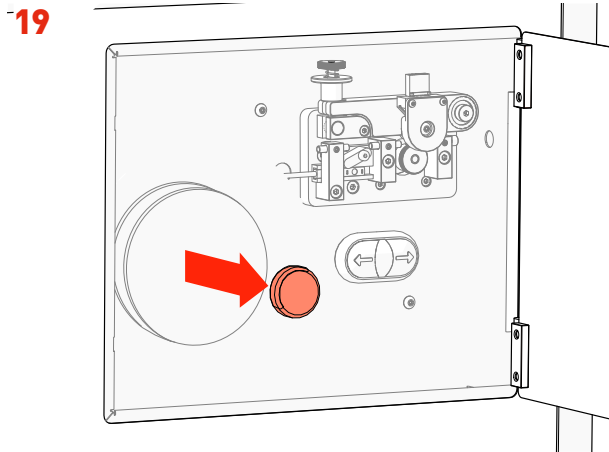

- Remove the *Reel Cap Cover*.

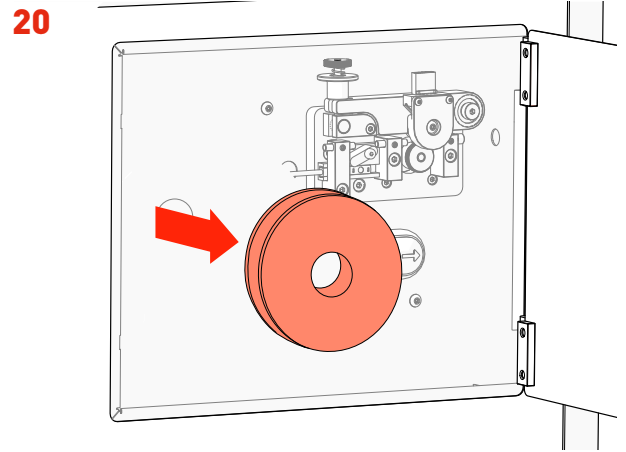

- Remove the *Reel Backing Plates*.

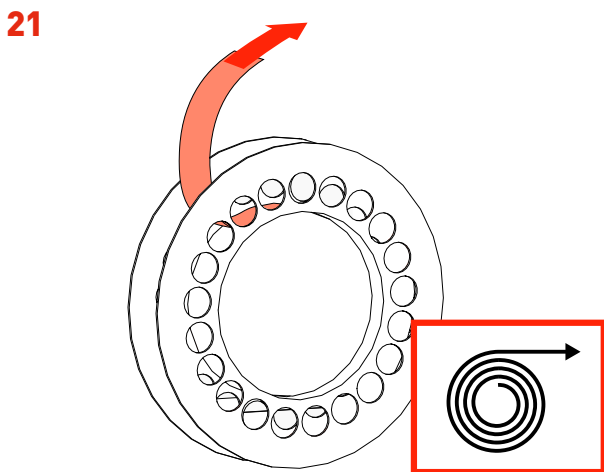

- Remove the new *PickupLine™ Reel* from its sterile packet and dispose of the *Securing Tape/Velcro*.

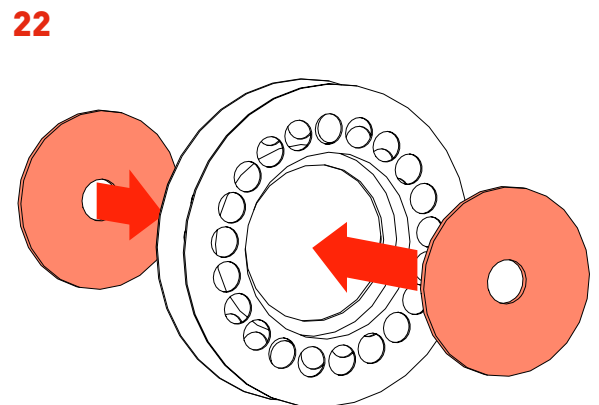

- Fit the *Reel Backing Plates* into the new *PickupLine™ Reel*.

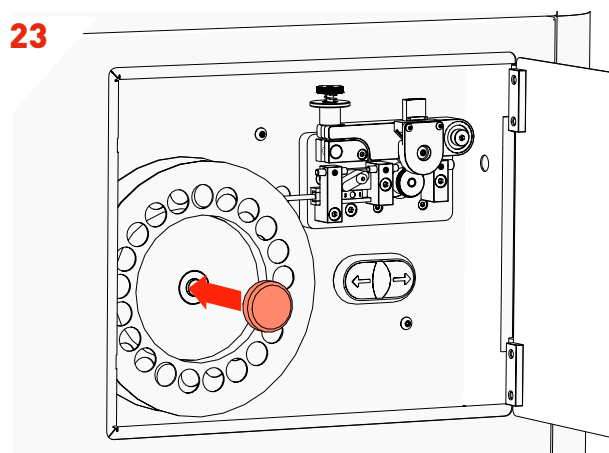

- Fit the new *PickupLine™ Reel* ensuring it feeds in a clockwise direction.
- Replace the *Reel Cap Cover*.

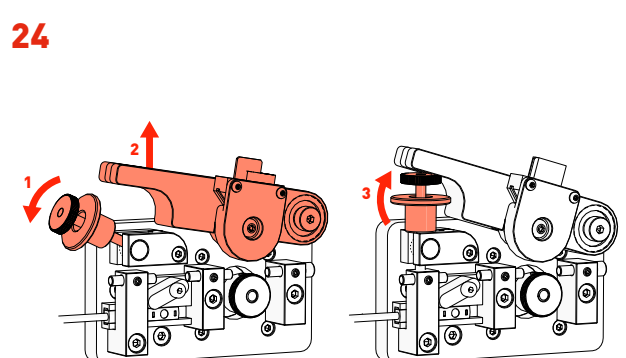

- Carefully lift the *Tension Lever* and rest it on the *Spring Catch* as shown.

UNBOXING & ASSEMBLY

25

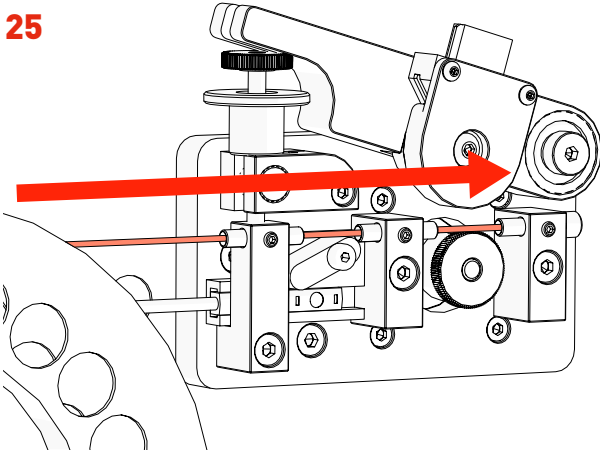

- Gently feed the *PickupLine™* by hand through the 3 *Entry Guides*. The *PickupLine™* is sterilised at the nozzle but for extra sterility gloves should be worn.
- If you meet resistance, pull back slightly and re-feed.

26

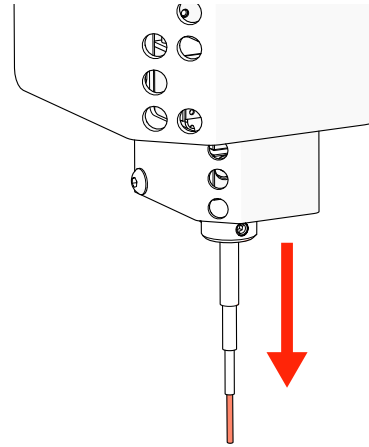

- Feed the *PickupLine™* until it protrudes 10mm from the *Kinematic Nozzle*.

27

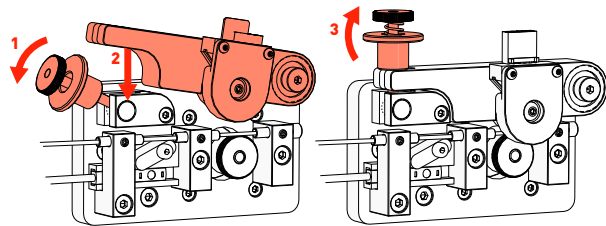

- Reset the *Tension Lever*.

28

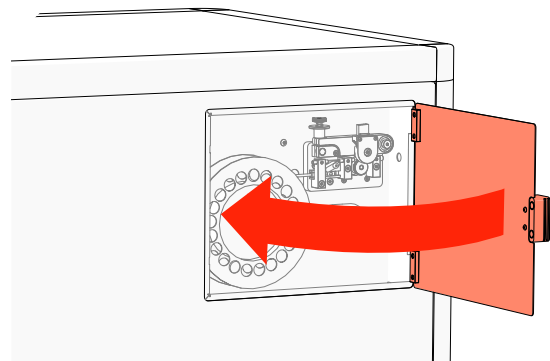

- Close the *PickupLine™ Compartment*.

29

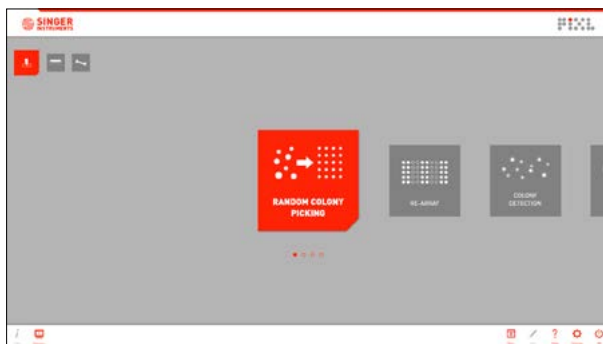

- Boom! You're ready to PIXL!

30

DOOR CONTROLS

Here's a quick guide on how to control the automatic doors using the software.

DOOR CONTROLS

IN A WORKFLOW

1

- Pop-up screens appear at specific points during workflows to control the main door and blackout screens.
- Press the *Open/Close* icon to Open/Close the Main Door or Blackout screen. Press *Cancel* to return to the previous screen.



IN THE MENU

1

- The Door and Blackout Screen can also be controlled using the menu on the *Lower Navigation Bar*.
- Selectable buttons will be displayed in red.

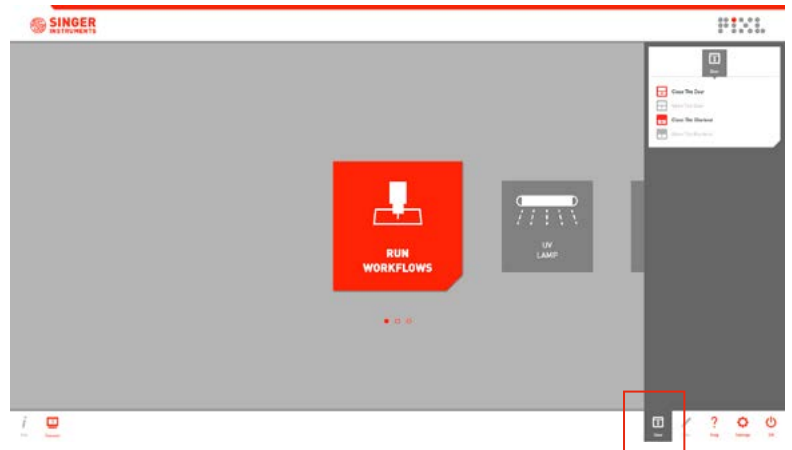

2

- When an option is selected, a door moving animation will appear and the door or blackout screen will move.

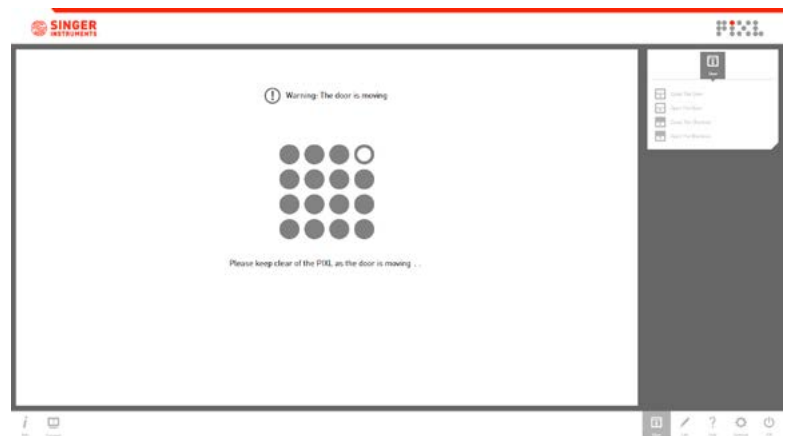

DOOR CONTROL OPTIONS



Close the Door



Open the Door



Close the Blackout



Open the blackout

RANDOM COLONY PICKING

Let's take a quick tour of the Random Colony Picking program to get you started with PIXL. Click *Run Workflows* then select *Random Colony Picking*.

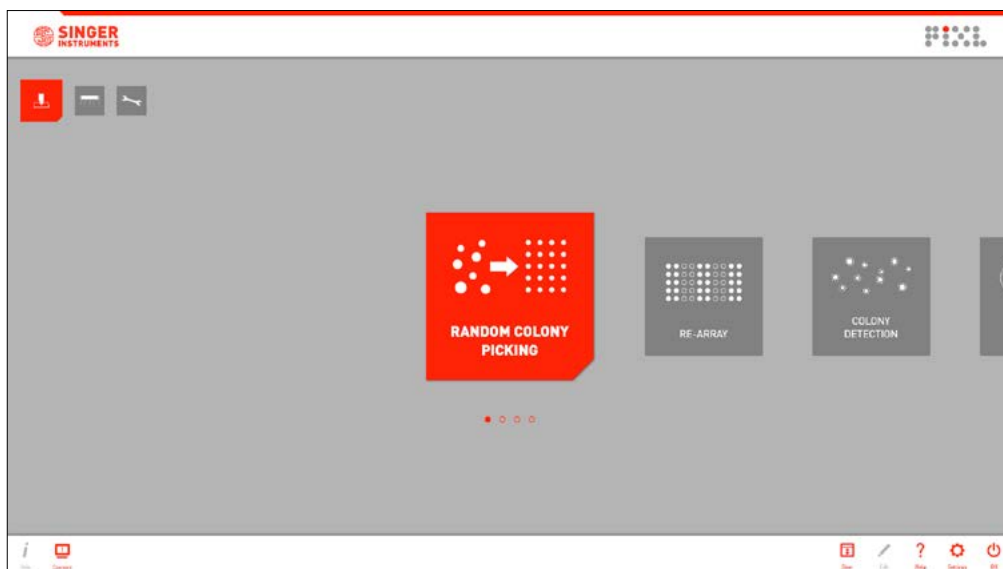

RANDOM COLONY PICKING OVERVIEW

1

- During project setup you can name your project and select from 3 workflow options:
Blank - Start a new project and select settings as you step through the software.
Last used - Select the settings you last used and proceed to plate loading.
Template - Select from a list of pre-made template settings and proceed to plate loading.
- The first time you use the software you will only have the option to use a blank project. Learn how to save a template on page 61.
- Click the *Select Source Plate* → button to move to the next stage.

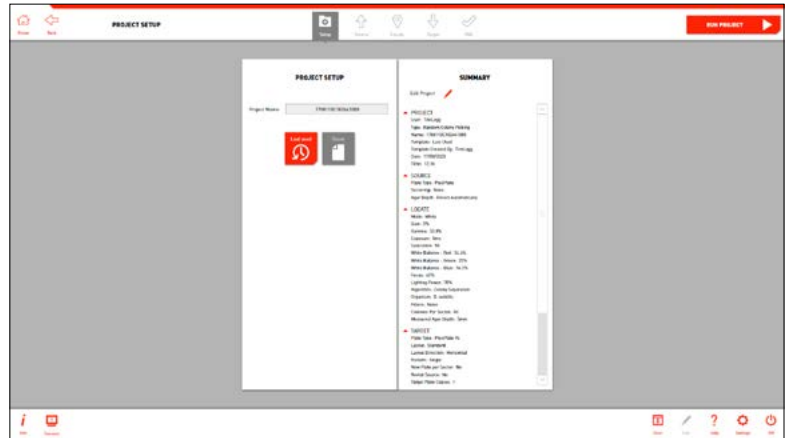

2

- Select the type of source plate that you plan on using. This is the plate you want to pick from.

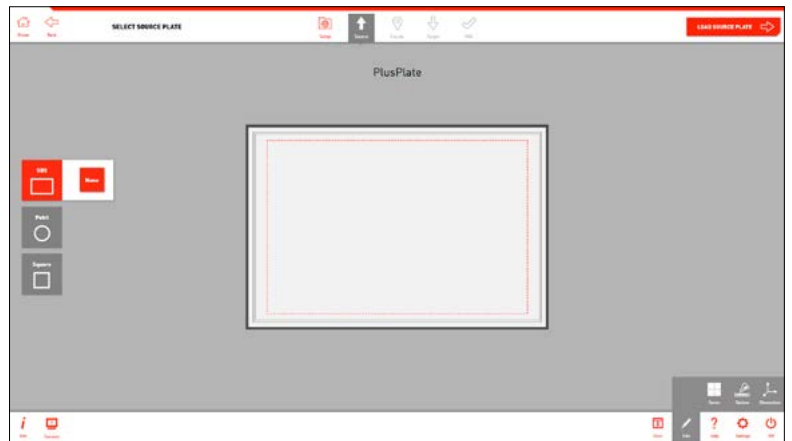

3

- Use the *Edit Options* on each stage to add detailed settings to your plate.
- At this stage you can add sectors to your plate or add specific dimensions/agar depth.
- Click the *Load Source Plate* → button to move to the next stage.

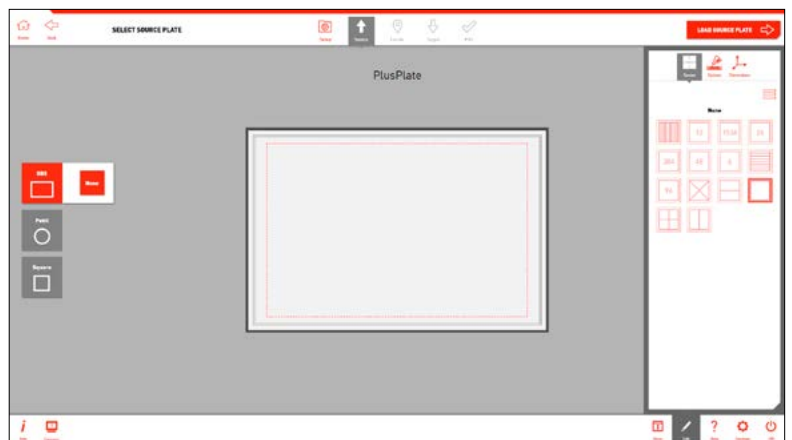

RANDOM COLONY PICKING OVERVIEW

4

- Remove the lid and load your *Source Plate* into the *Source Plate Bay*, as shown on-screen.
- NOTE: If you have the incorrect source plate bay installed, simply switch it out for the correct one. The source plate bays attach via magnets so can be switched in seconds. Follow instructions on page 58.

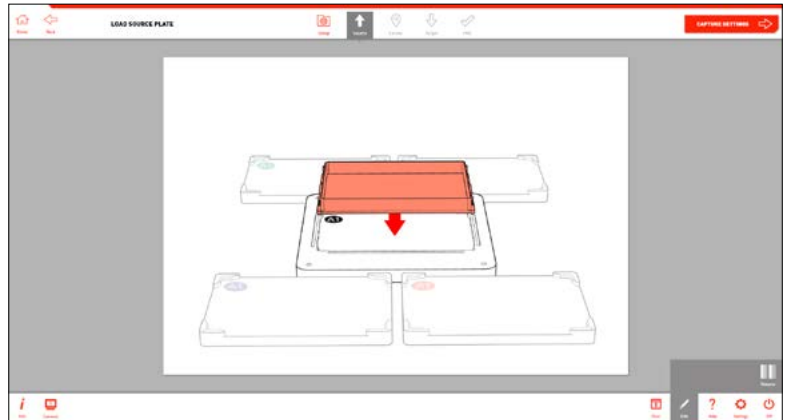

5

- Use the *Rename Option* in the edit menu to scan a barcode or manually add a name to your plate.
- Click the *Capture Settings* → button to move onto the next stage.

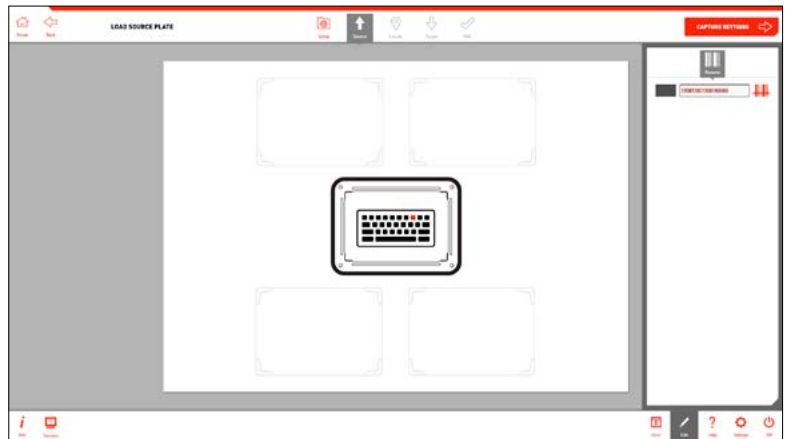

6

- A door control screen will appear to move onto the next stage.
- Click the *Close Blackout* button to close the Blackout Screen and continue to the next stage.
- Or click on the *Cancel* button to return to the previous stage.

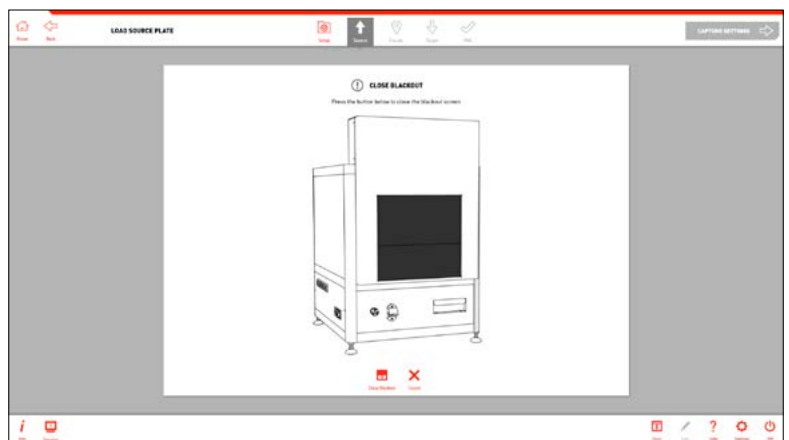

RANDOM COLONY PICKING OVERVIEW

7

- Select one of the 6 lighting channels. The wavelengths are listed on-screen.
- Use the *Imaging Option* in the edit menu to adjust the camera settings if necessary.
- Click the *Select Colonies* → button to move on.

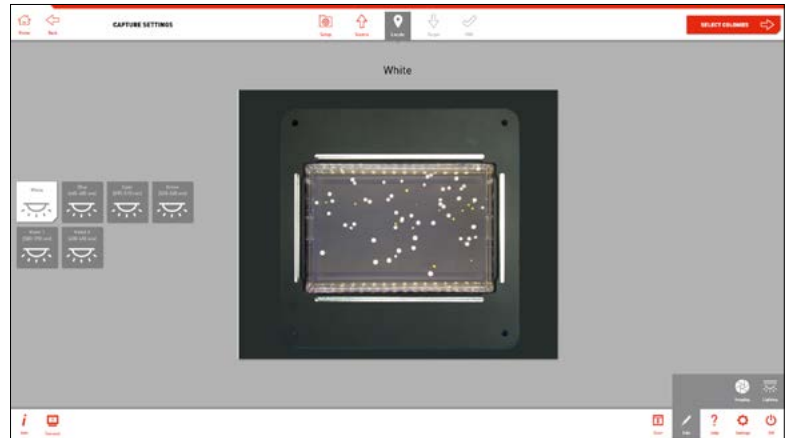

8

- If a camera filter is required, place it into the camera's *Filter Tray* before moving to the Select Colonies stage. Detailed instructions can be found on page 60.

Remember to take out any filters used when you're finished.

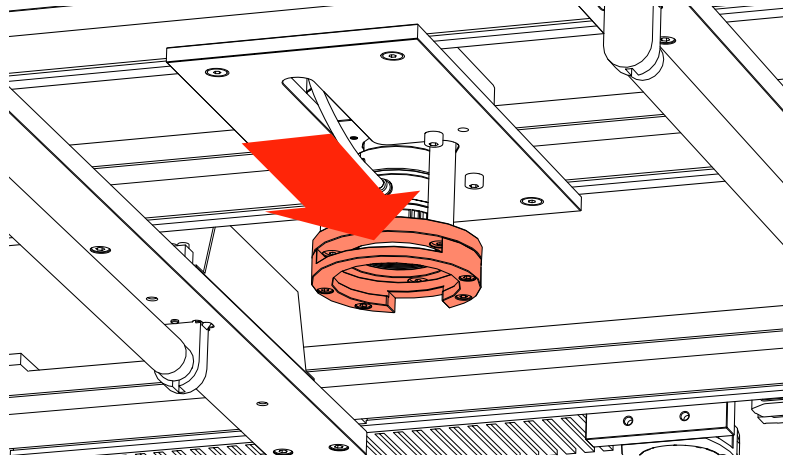

9

- PIXL will now analyse the image to detect the colonies.

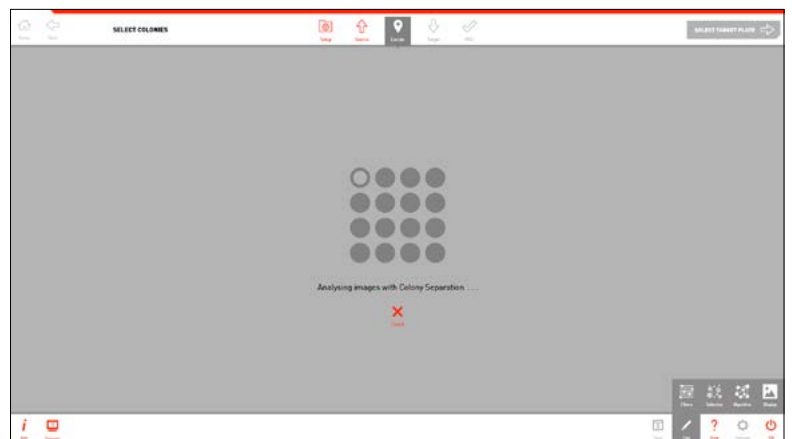





RANDOM COLONY PICKING OVERVIEW

10

- You can see how many colonies are detected and, of those, how many are selected for picking.
- The edit menu has 4 options:
 - Filters** - Filter your picking selection by: proximity, intensity, colour, circularity and area.
 - Selection** - Choose how many colonies you want to pick from each sector and what parameters to choose them by.
 - Algorithm** - Select detection based on organism.
 - Display** - Choose how to view your preview plate image.
- Manually deselect colonies by clicking on them.



11

- Use the *Filters Options* in the edit menu to select colonies within desired parameters. To edit a filter, click on it and use the sliders or type in the value boxes to create a range.
-  deletes the filter
-  adds a second range for a filter.
-  Colonies that meet the filter conditions have a bright red outline.
-  Colonies that don't meet the filter conditions have a pale blue outline.

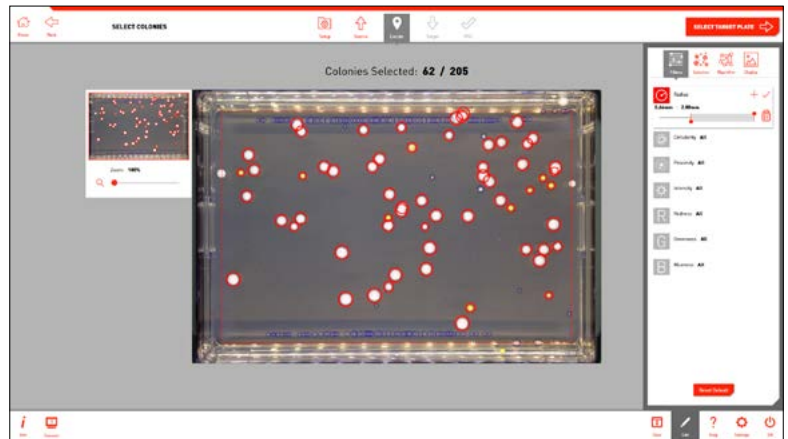

RANDOM COLONY PICKING OVERVIEW

12

- Colony selection can be refined using the *Selection Options*. Along with the automatic selection options you have 3 manual selection options:
- 1. **Manually select colony** - This tool is selected by default. Click on individual colonies to select or deselect them.

 Colonies that meet the filter conditions but have been deselected manually have a pale red outline.

 Colonies that don't meet the filter conditions but have been manually selected have a bright blue outline.

The number of colonies you have manually selected or deselected are displayed in the tool window.

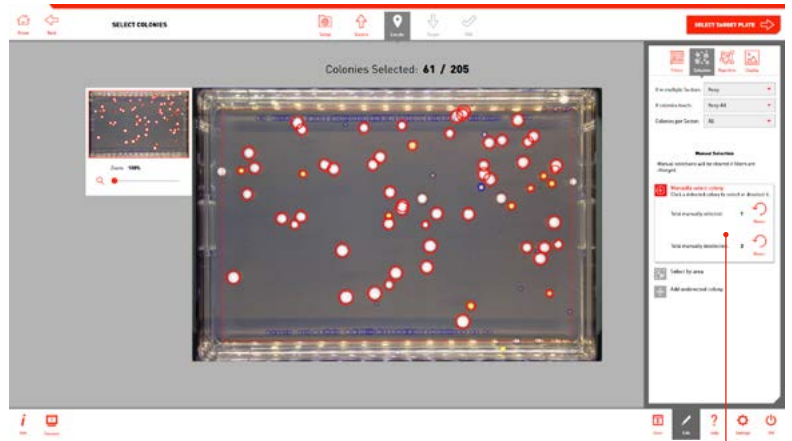

These selections can be reset using the  icon.

If you go back and edit your filters, any manual selections or deselections you have made will be reset.

- 2. **Select area** - Click on the *Select Area* tool to expand the tool box. Drag over a group of colonies to select or deselect the entire group.

When you have dragged an area over the plate, the tool box displays how many colonies are in that area. Colonies on the edge of the area will only be included if the check box is selected.

You have the option to select or deselect all colonies in that area. You can also click cancel to reset the area.

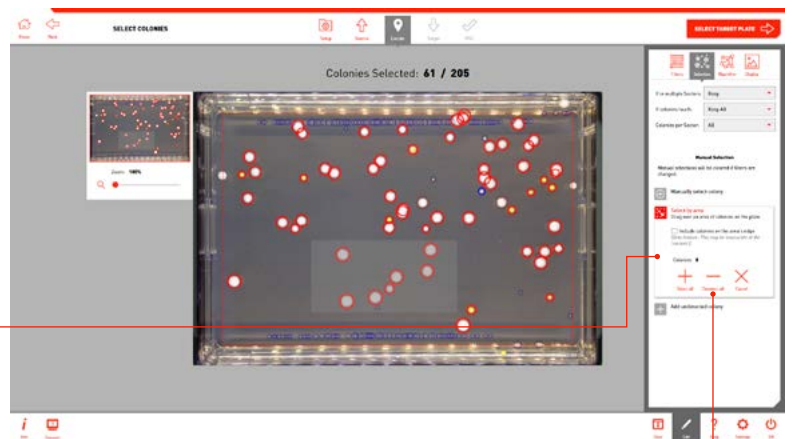

RANDOM COLONY PICKING OVERVIEW

- 3. Add undetected colony - Click on the *Add Undetected Colony* tool to expand the tool box. Click anywhere on the plate image to add a new location to be picked. This is useful for picking colonies that PIXL hasn't managed to detect, or for adding a control pick on a blank area of the plate.



Undetected colonies that you add are shown by a red cross.

The number of colonies you have manually selected or deselected are displayed in the tool window.

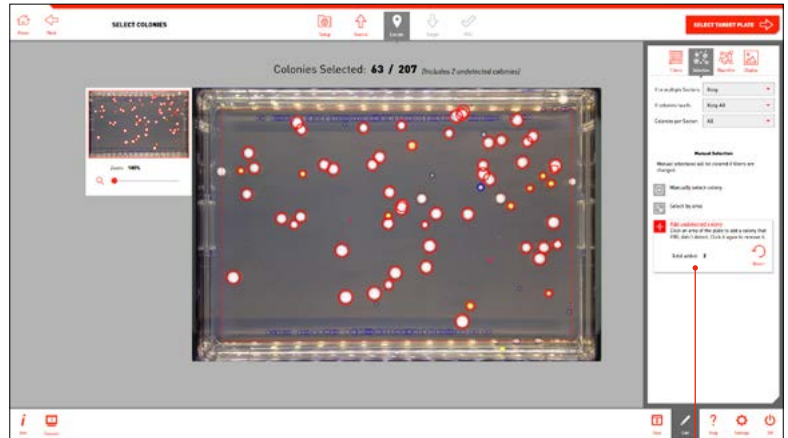

These selections can be reset using the icon.

- Click the *Select Target Plate* → button to move to the next stage.

13

- Select the type of target plate that you plan on using. This is where you will deposit your colonies.
- The edit menu has 4 options:
 - Layout** - Exclude rows or columns.
 - Replicates** - Choose how many copies of each colony you want to pin.
 - Plates** - Select any copies you want to make of each target plate.
 - Dimensions** - Enter detailed dimensions of your plate or choose from a list.

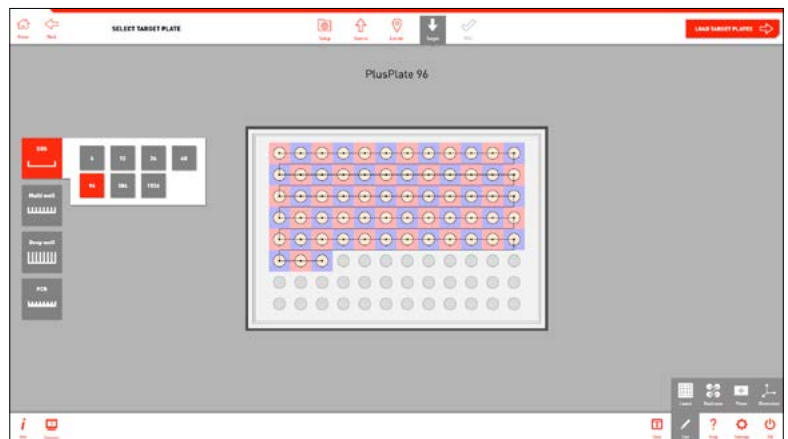

14

- With the *Layout Options* in the edit menu you can exclude rows or columns on your plate from being pinned into.
- You can also select the start row/column position and apply this to all of your target plates or just the first.

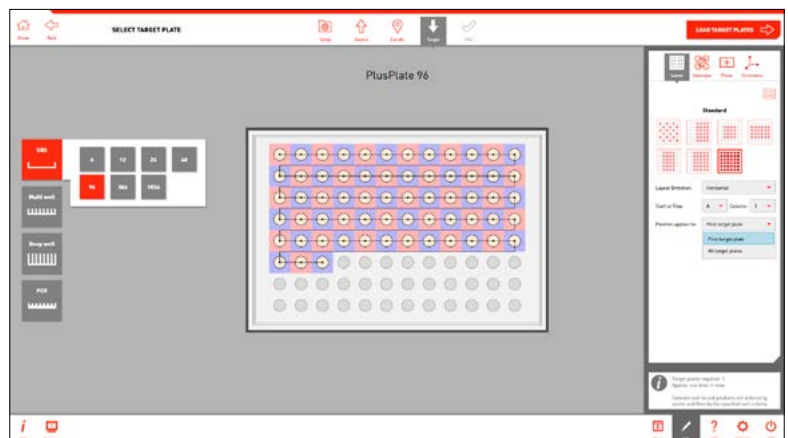

RANDOM COLONY PICKING OVERVIEW

15

- With the *Replicates Options* in the edit menu you can set the number of colony replicates as well as how they're laid out on the plate.
- Click the *Load Target Plate* → button to move to the next stage.

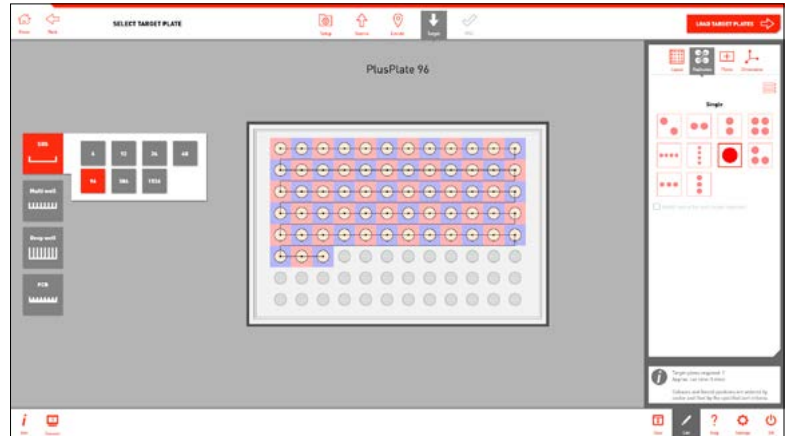

16

- A door control screen will appear to move onto the next stage.
- Click the *Open Blackout* button to open the Blackout Screen and continue to the next stage.
- Or click on the *Cancel* button to return to the previous stage.

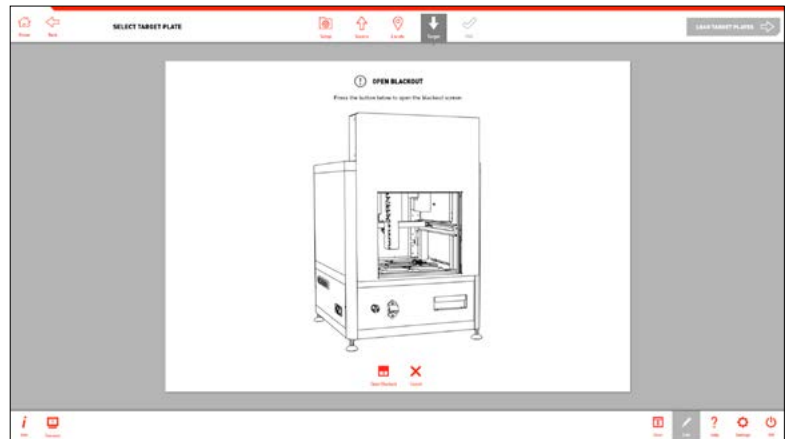

17

- Remove the lid and load your *Target Plate(s)* into the *Target Plate Bay(s)*, as shown on-screen.
- Plates can be renamed in the edit menu.

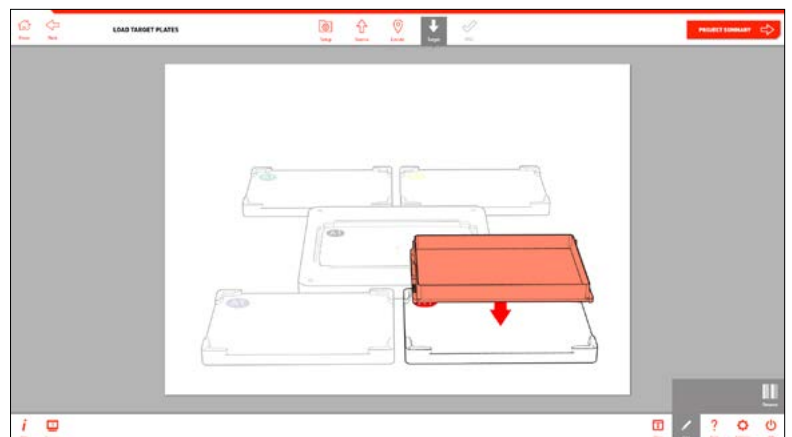

RANDOM COLONY PICKING OVERVIEW

18

- Use the *Rename Option* in the edit menu to scan a barcode or manually add a name to your plate.
- Click the *Project Summary* → button to move onto the next stage.

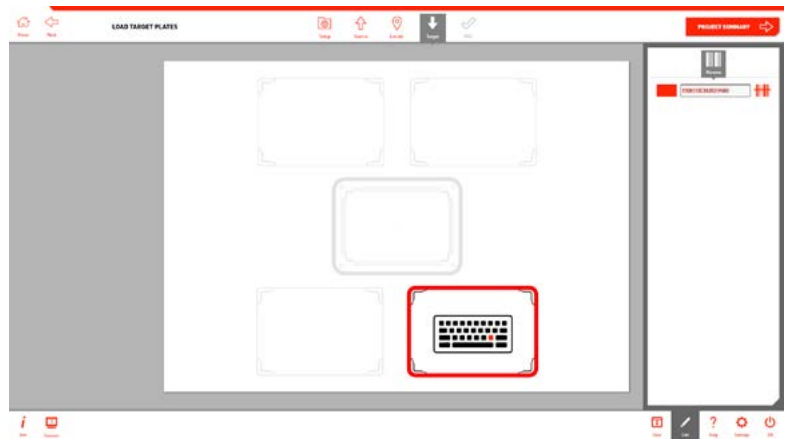

19

- A door control screen will appear to move onto the next stage.
- Click the *Close Door* button to close the Main Door and continue to the next stage.
- Or click on the *Cancel* button to return to the previous stage.



20

- Here is a summary of your pinning routine. For full details of your routine click the *Info Button* in the bottom left.
- If necessary, use the *Edit Menu* to change the pinning and mixing settings.

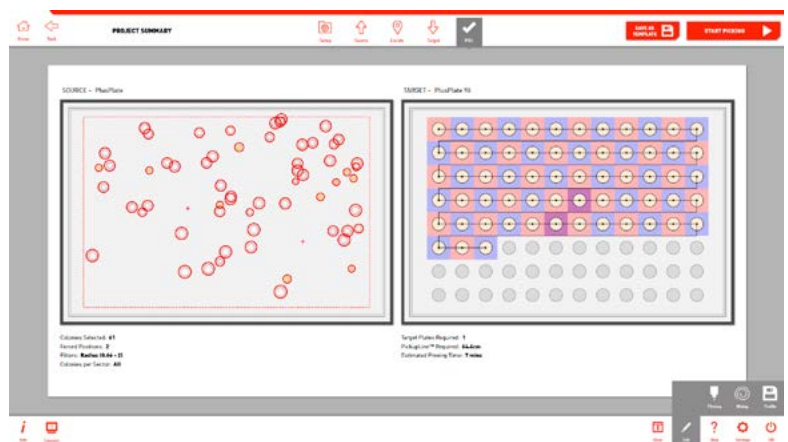

RANDOM COLONY PICKING OVERVIEW

21

- To edit the PIXL pinning and mixing settings, use the options in the edit menu as show.
- These options can be saved as a profile and recalled for future projects. See page 62.
- At this stage you can also save all of your project settings as a template by clicking Save as Template. Detailed instructions can be found on page 61.
- When you're happy, press *Start Picking* > to initiate the picking program.

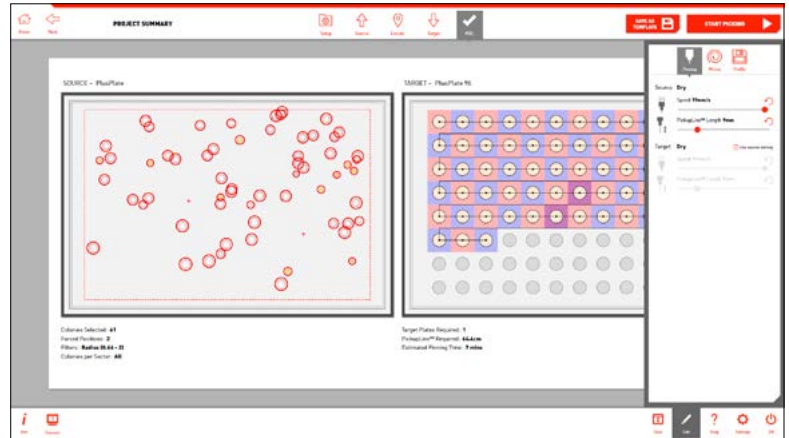

22

- The software will take a few moments to generate the picking program.

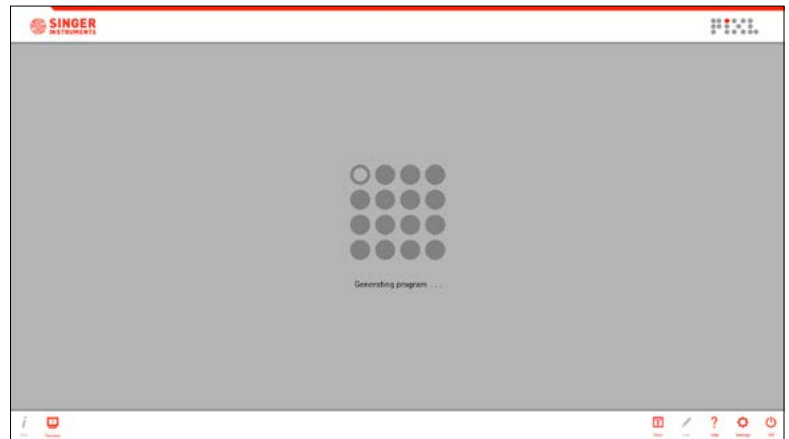

23

- The pinning summary screen shows you the current progress of the pinning routine.
- If the routine requires more than 4 target plates you will be notified when you need to swap in some fresh target plates.
- You can pause or abort the program, or edit the pinning and mixing options mid routine.

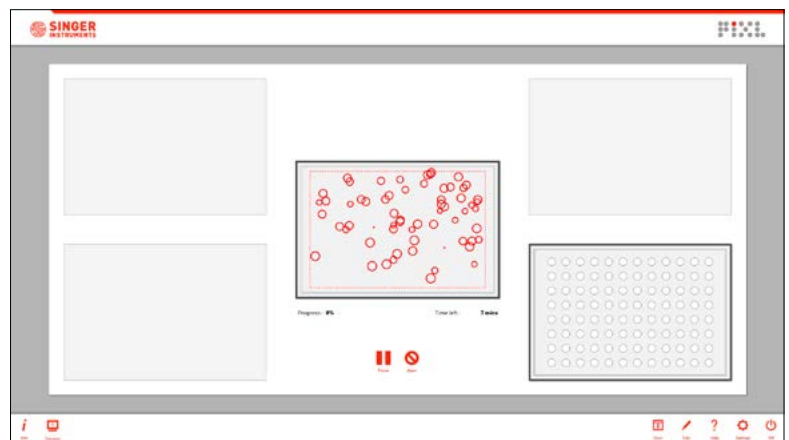

RANDOM COLONY PICKING OVERVIEW

24

- Once the pinning routine has finished, the summary screen will highlight any unsuccessful pins.
- Use the *Export* option to view all exported colony, routine information and templates for Re-arraying.
- To repeat the same routine click the *Repeat* button.

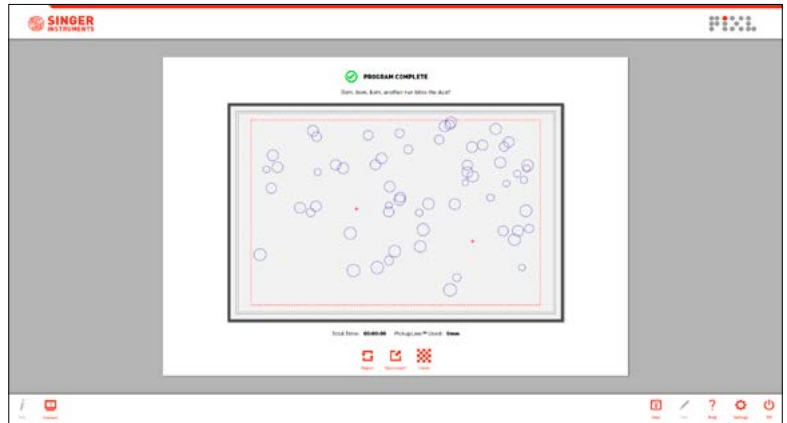

25

- A door control screen will appear to move onto the next stage.
- Click the *Open Door* button to open the Main Door and continue to the next stage.
- Or click the *Cancel* button to return to the previous stage.



26

- Replace the plate lids and remove your *Source and Target Plates* from the from the *Source and Target Bays*, as shown on-screen.

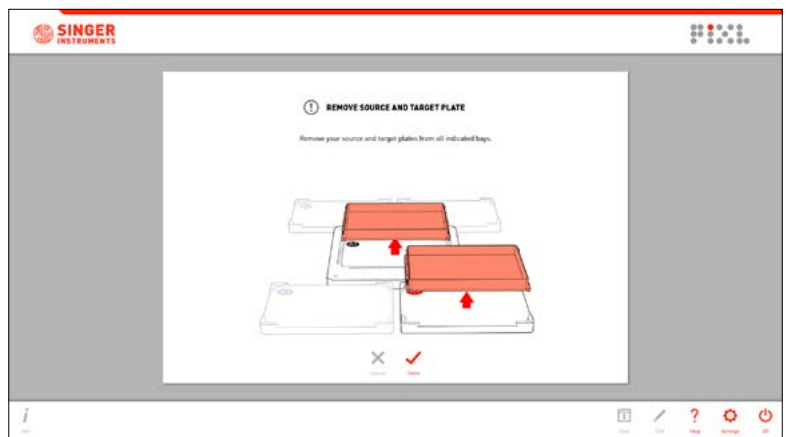

RE-ARRAY

The Re-array workflow allows you to pick colonies from user defined locations and place them to user defined positions.

Let's take a look! Click *Run Workflows* then select *Re-array*.

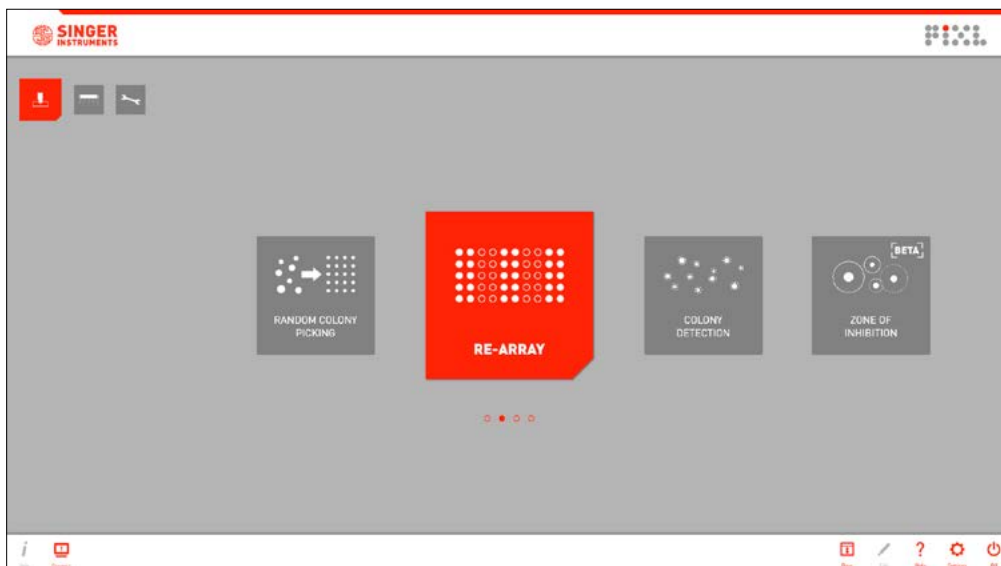

RE-ARRAY OVERVIEW

1

- During project setup you can name your project
- Click the *Import Data* → button to move to the next stage.

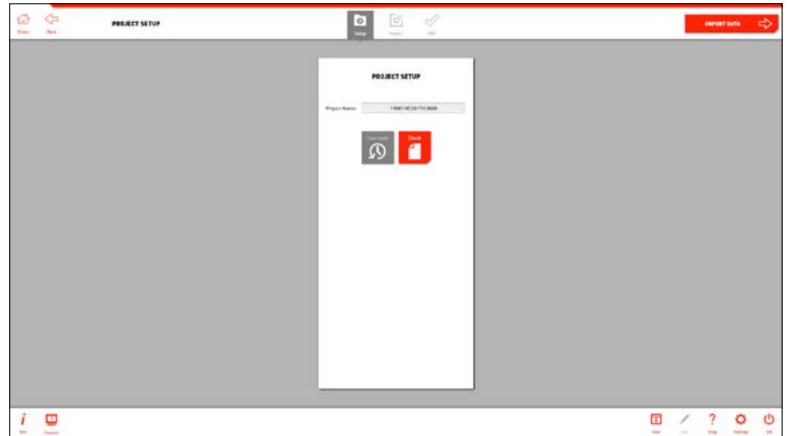

2

- Select the location of your re-arraying file from the directories list.
- Removable storage drives are shown automatically but specific folders on the PIXL will need to be added using the edit menu, as shown in step 3.

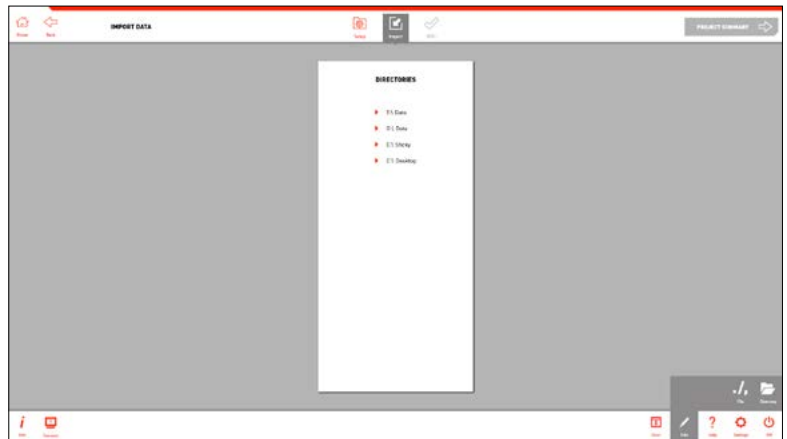

3

- Open the directories window in the edit menu and click *Add* to add a new file location.
- You can also edit the file settings from here.

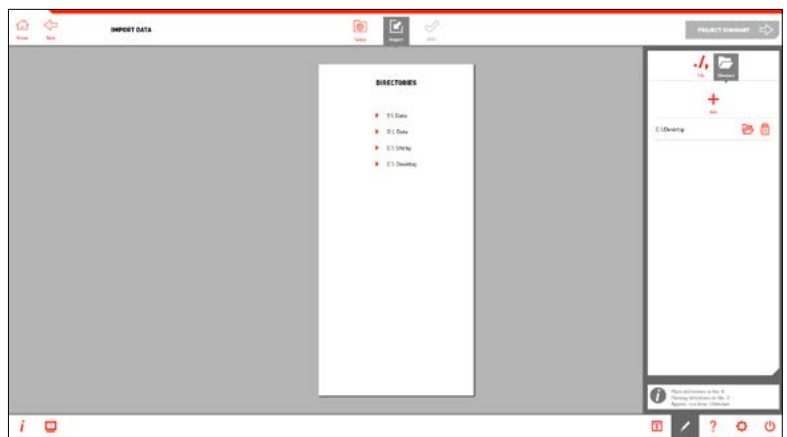

RE-ARRAY OVERVIEW

4

- Click your chosen directory to view the compatible files from that location
- Re-array templates are created with all Random Colony Picking and Colony Detection export files. To learn how to edit export templates and create files for re-arranging, see page 68.

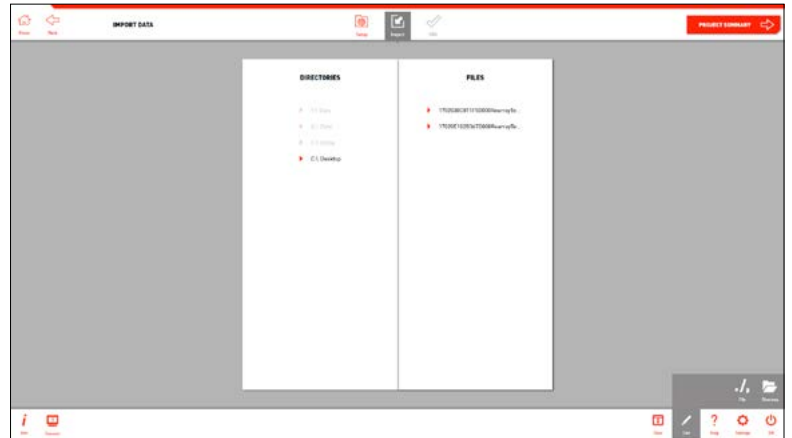

5

- Click on your chosen file and PIXL will check for errors. Any errors will be listed.
- If the file is error-free, click the *Project Summary* → button to move to the next stage.

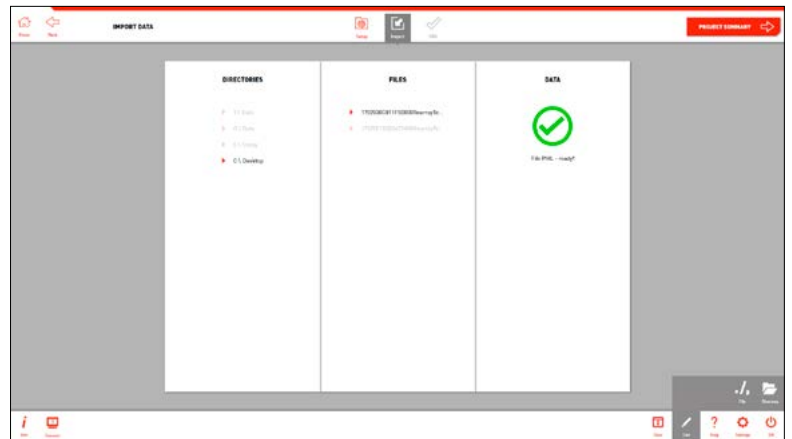

6

- Here is a summary of your pinning routine. For full details of your routine click the *Info Button* in the bottom left.
- If necessary, use the *Edit Menu* to change the pinning and mixing settings.
- Click the *Start Picking* → button to initiate the re-arranging program.

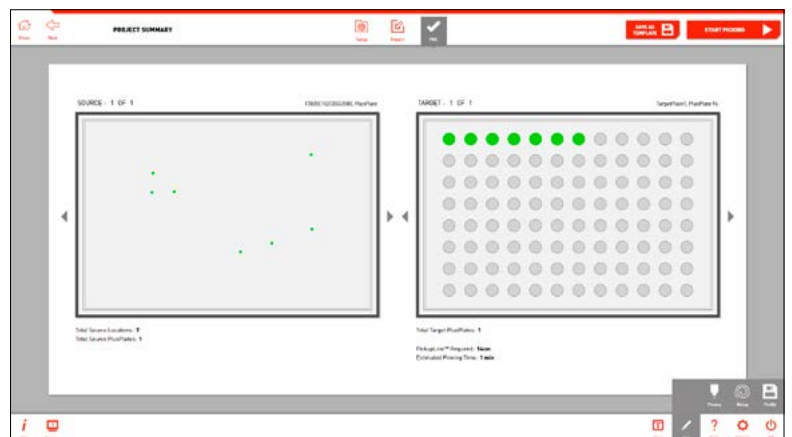

RE-ARRAY OVERVIEW

7

- The pinning summary screen shows you the current progress of the pinning routine.
- If the routine requires more than 4 target plates you will be notified when you need to swap in some fresh target plates.
- You can pause or abort the program, or edit the pinning and mixing options mid routine.

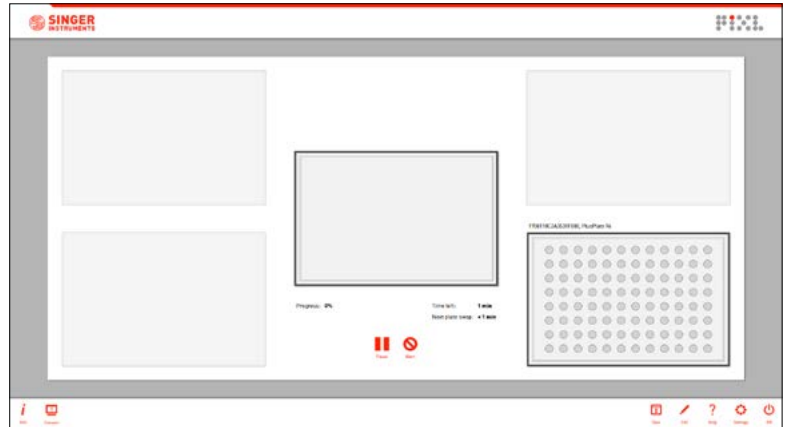

8

- Once the pinning routine has finished, the summary screen will highlight any unsuccessful pins.
- Use the *Export* option to export all colony and routine information.
- To repeat the same routine click the *Repeat* button.
- *Finish* will take you back to the workflows menu.

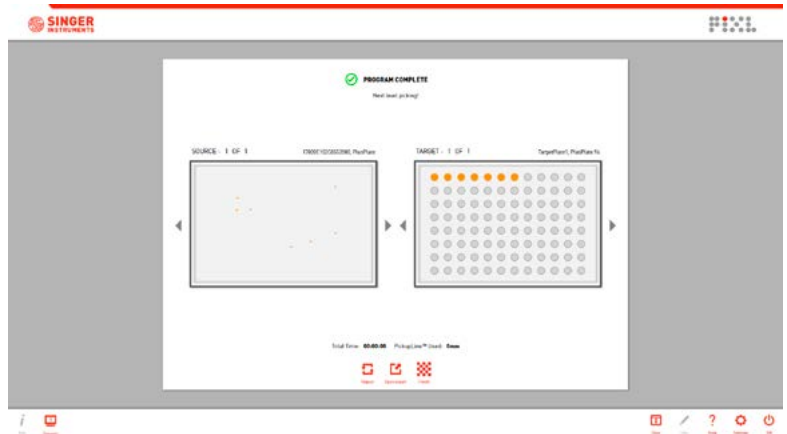

COLONY DETECTION

The Colony Detection workflow allows you to quickly image a plate and export the colony positions without having to pick from it.

Let's take a look! Click *Run Workflows* then select *Colony Detection*.

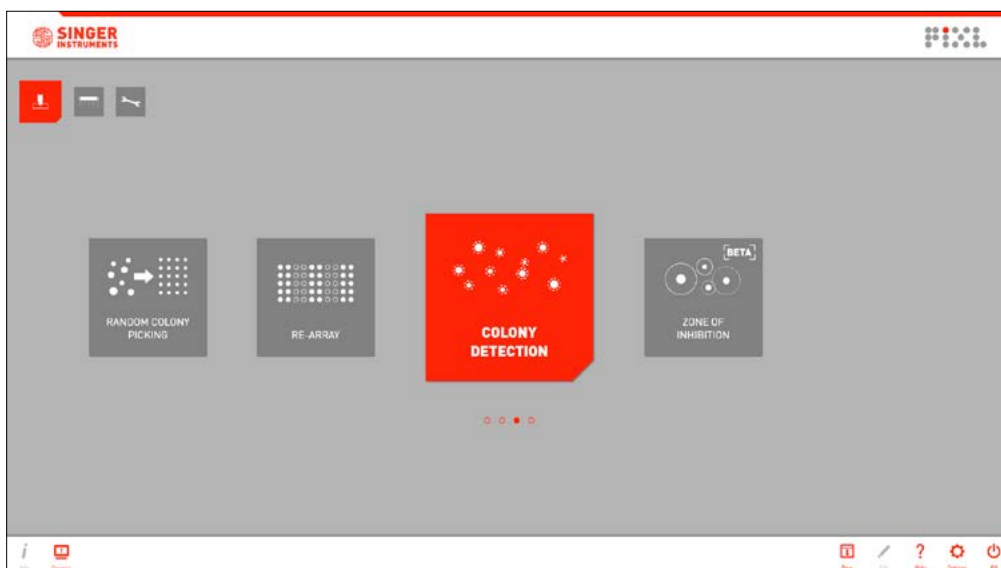

COLONY DETECTION OVERVIEW

1

- During project setup you can name your project and select from 3 workflow options:
Blank - Start a new project and select settings as you step through the software.
Last used - Select the settings you last used and proceed to plate loading.
Template - Select from a list of pre-made template settings and proceed to plate loading.
- The first time you use the software you will only have the option to use a blank project. Learn how to save a template on page 61.
- Click the *Select Source Plate* → button to move to the next stage.

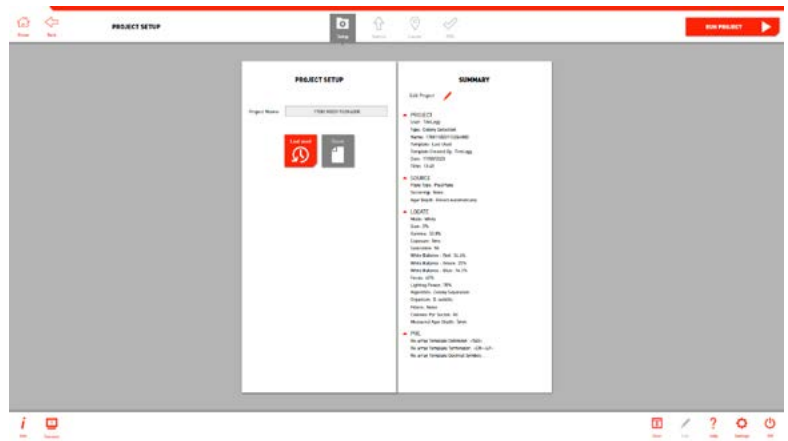

2

- Select the type of source plate that you plan to image.

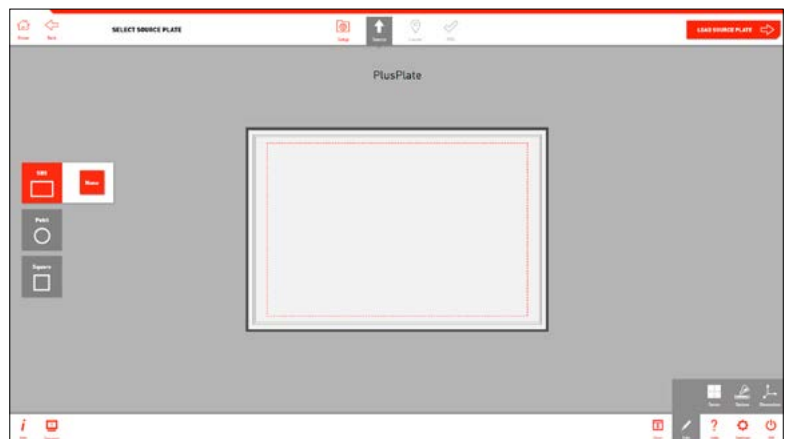

3

- Use the *Edit Options* on each stage to add detailed settings to your plate.
- At this stage you can add sectors to your plate or add specific dimensions/agar depth.
- Click the *Load Source Plate* → button to move to the next stage.

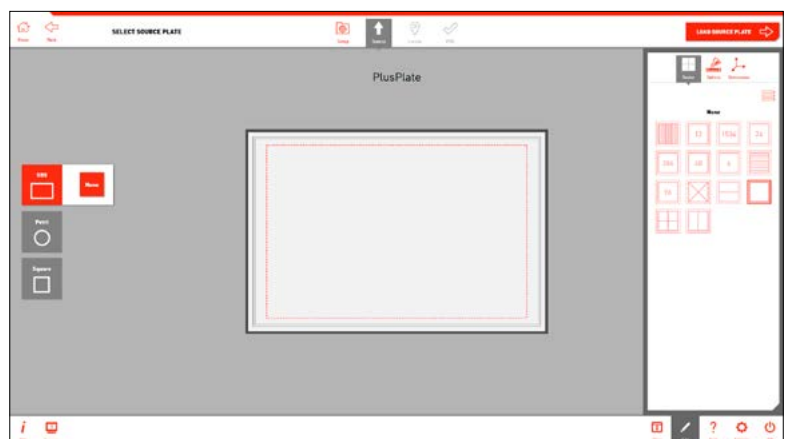

COLONY DETECTION OVERVIEW

4

- Remove the lid and load your *Source Plate* into the *Source Plate Bay*, as shown on-screen.
- NOTE: If you have the incorrect source plate bay installed, simply switch it out for the correct one. The source plate bays attach via magnets so can be switched in seconds. Follow instructions on page 58.

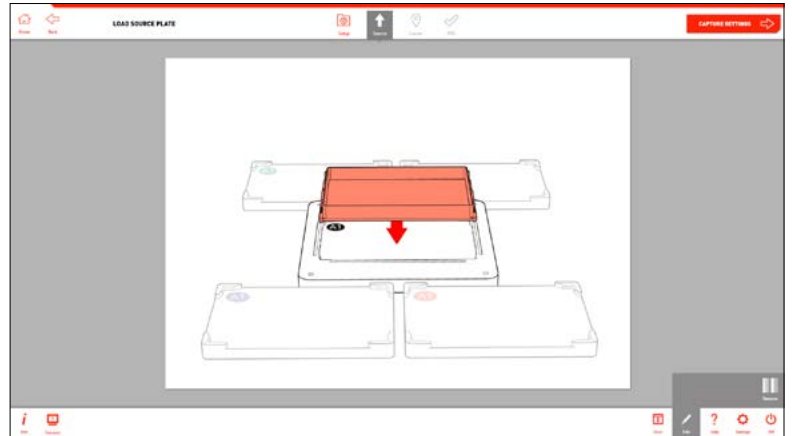

5

- Use the *Rename Option* in the edit menu to scan a barcode or manually add a name to your plate.
- Click the *Capture Settings* → button to move onto the next stage.

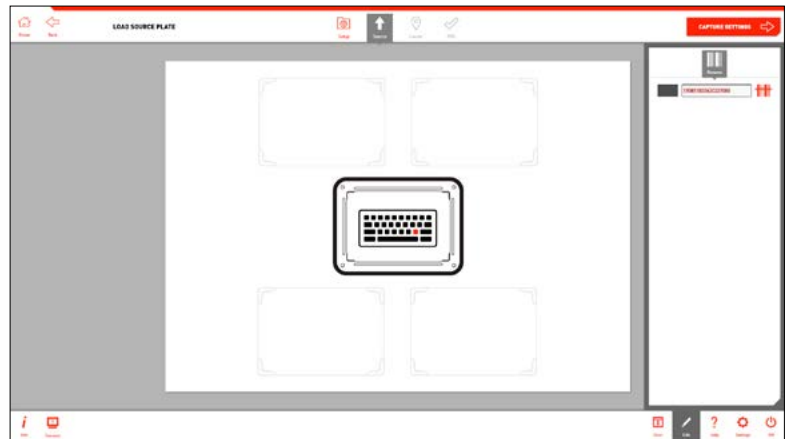

6

- A door control screen will appear to move onto the next stage.
- Click the *Close Blackout* button to close the Blackout Screen and continue to the next stage.
- Or click on the *Cancel* button to return to the previous stage.

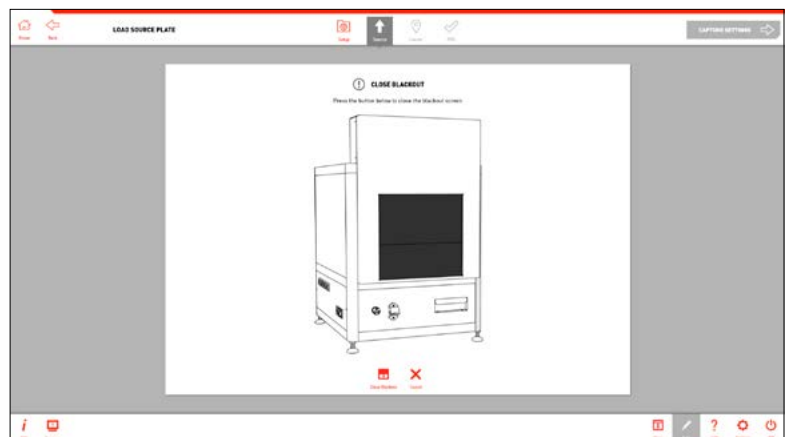

COLONY DETECTION OVERVIEW

7

- Select one of the 6 lighting channels. The wavelengths are listed on-screen.
- Use the *Imaging Option* in the edit menu to adjust the camera settings if necessary.
- Click the *Select Colonies* → button to move on.

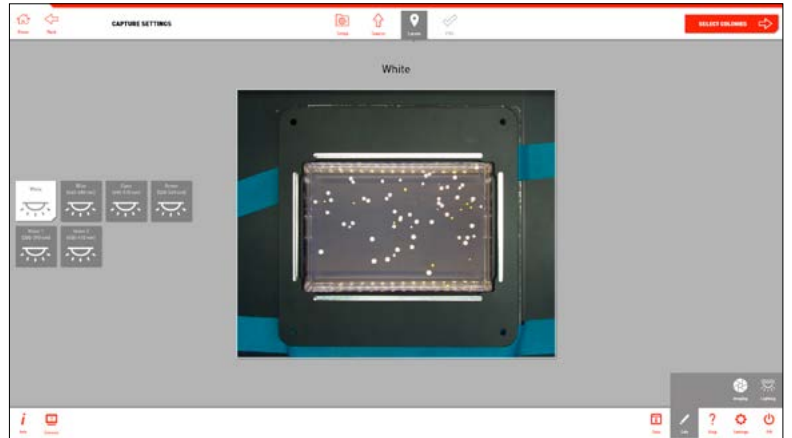

8

- If a camera filter is required, place it into the camera's *Filter Tray* before moving to the Select Colonies stage. Detailed instructions can be found on page 60.

Remember to take out any filters used when you're finished.

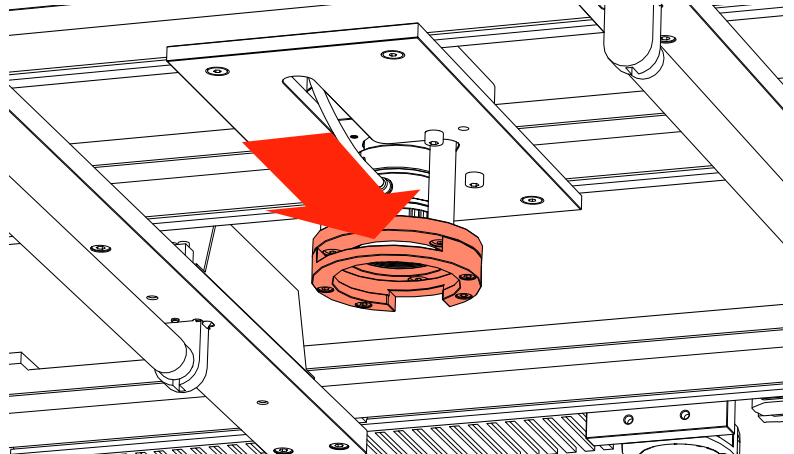

9

- PIXL will now analyse the image to detect the colonies.

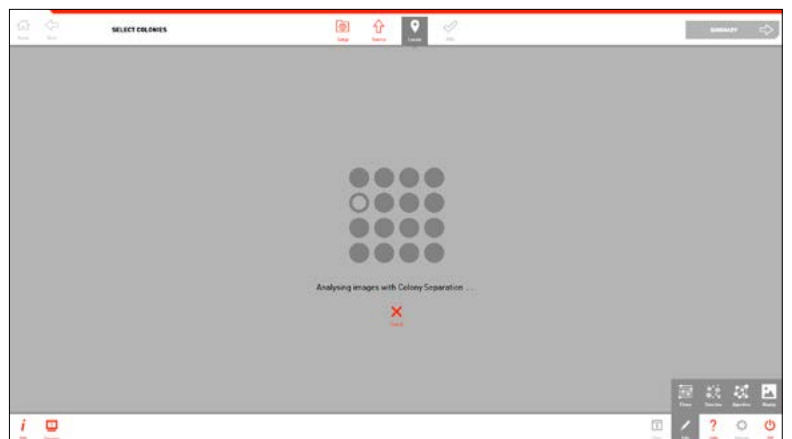

COLONY DETECTION OVERVIEW

10

- You can see how many colonies are detected and, of those, how many are selected for picking.
- The edit menu has 4 options:
 - Filters** - Filter your picking selection by: proximity, intensity, colour, circularity and area.
 - Selection** - Choose how many colonies you want to pick from each sector and what parameters to choose them by.
 - Algorithm** - Select detection based on organism and image contrast.
 - Options** - Choose how to view your preview plate image.
- Manually deselect colonies by clicking on them.



11

- Use the *Filters Options* in the edit menu to select colonies within desired parameters.

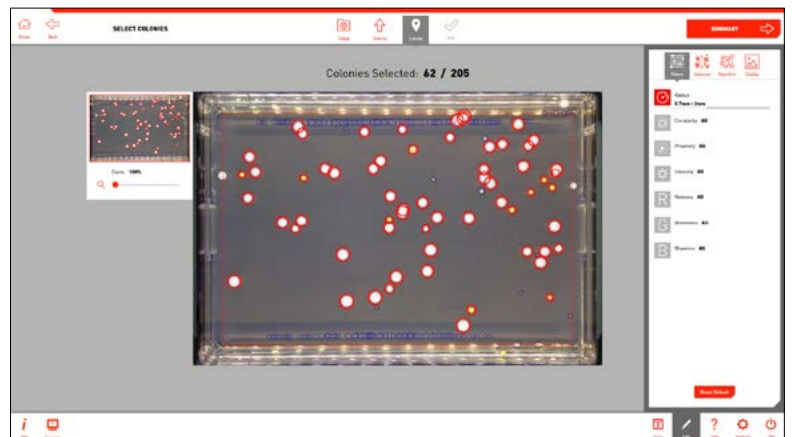

12

- Colony selection can be narrowed down even further by using the *Selection Options*.
- Click the *Summary* → button to move to the next stage.

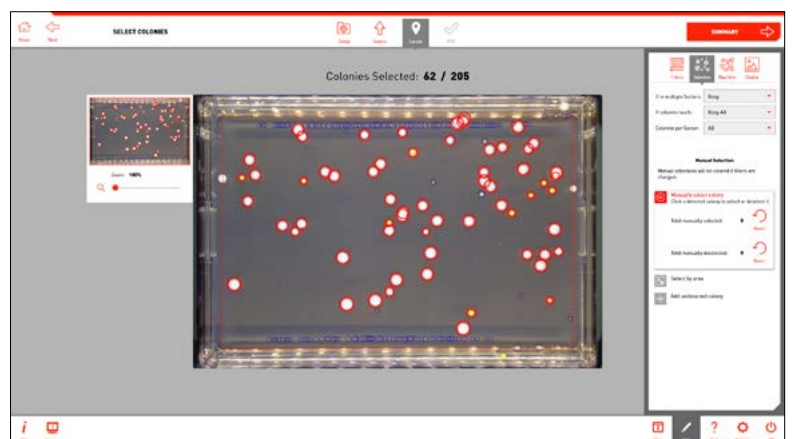

COLONY DETECTION OVERVIEW

12

- Here you will see a summary of the colonies selected for location export.



13

- Use the *Re-array Options* in the edit menu to change the format of the export file. This file will be the base of your Re-array file. Further details on creating Re-array files can be found on page 59.
- Click the *Finish* → button to move to the next export stage.



14

- Use the *Export* option to view all colony and routine information.
- This export will include a base Re-array template file, which lists the source colony locations. To turn this template into a working Re-array file, add the target plate information and pinning locations using the guide on page 68.

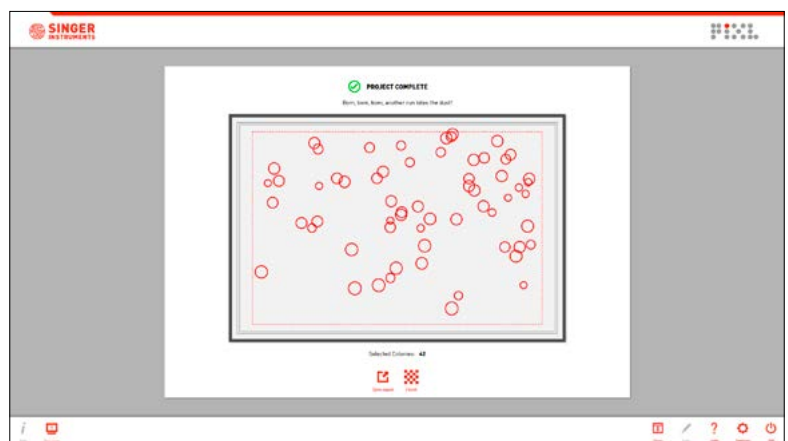

PICKING TO MALDI-TOF SLIDES

From PIXL 107 (Serial No: 000001058) onwards the PIXL baseplate has been upgraded to support Bruker MALDI-TOF targets. The blue target bay (Position 2) can be swapped out for an adapter, which will allow you to pin to Bruker MBT 96 and Bruker MTP 384 targets. Which can then be used as part of a downstream MALDI-TOF workflow.

To check if your PIXL is compatible, look at the blue target bay (Position 2). There will be 4 ball bearings in the place of the fixed target bay. This allows us to mount the removable adapters.

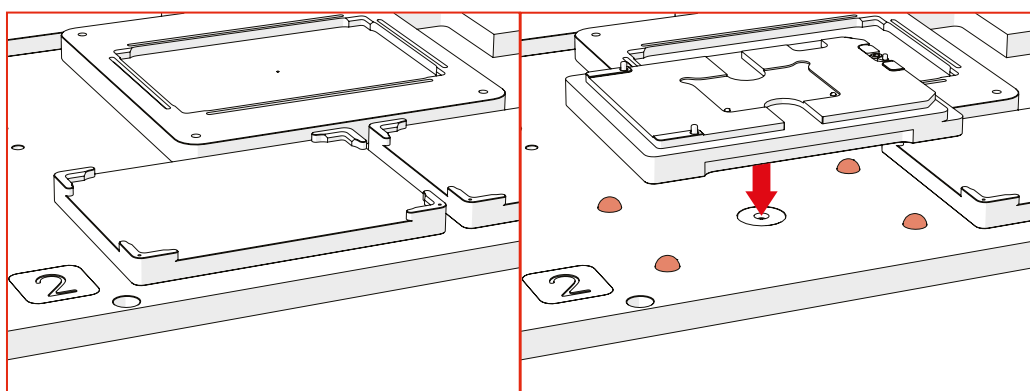

PIXL Fixed Target Bay

PIXL MALDI Target Bay

To pick to a MALDI-TOF target in the PIXL, click *Run Workflows* then select *Random Colony Picking*. Setup the project and follow Steps 1 - 11 as per the *Random Colony Picking* workflow instructions on page 17.

PICKING TO MALDI-TOF SLIDES OVERVIEW

1

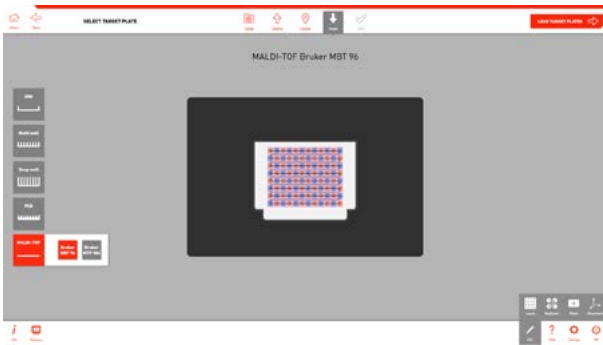

- Click on the *MALDI-TOF* plate type and select the MALDI-TOF target you would like to use as the target plate. This is where you will deposit your colonies.

3

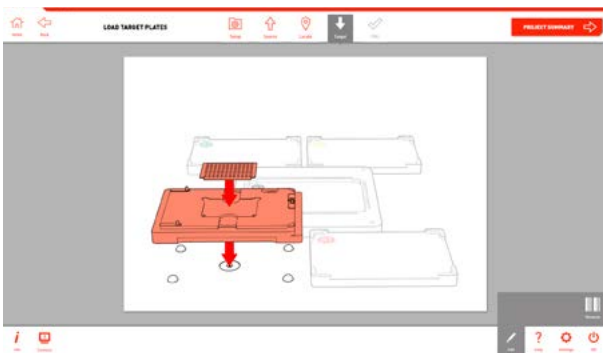

- Follow the onscreen diagram and insert the Bruker slide and adapter onto the target bay ball bearings.
- Use the diagrams below as a helpful guide to attach the slides to the adapters securely.

Bruker MBT 96 Slide

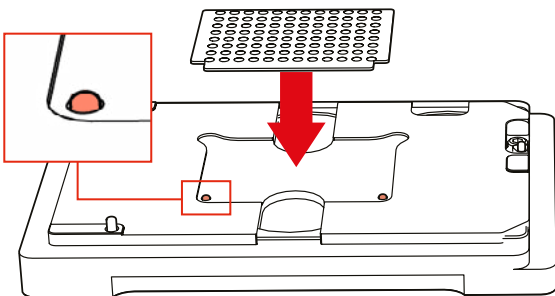

- Insert the Bruker MBT 96 target into the central well of the adapter. The small pins will fit into the notches on the slide and keep it in place.

2

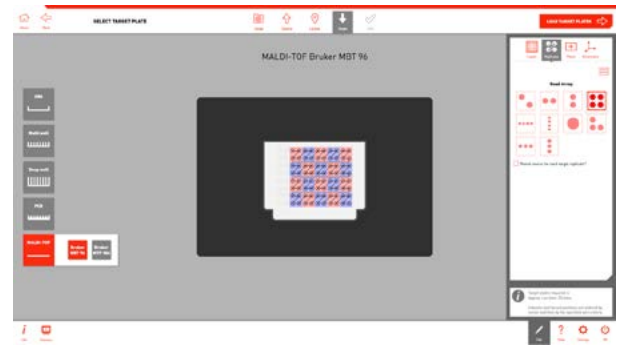

- The layout and replicate options for the selected MALDI-TOF target can be adjusted in the edit menu.
- Continue the workflow by clicking the *Load Target Plate* → button.

Bruker MTP 384 Slide

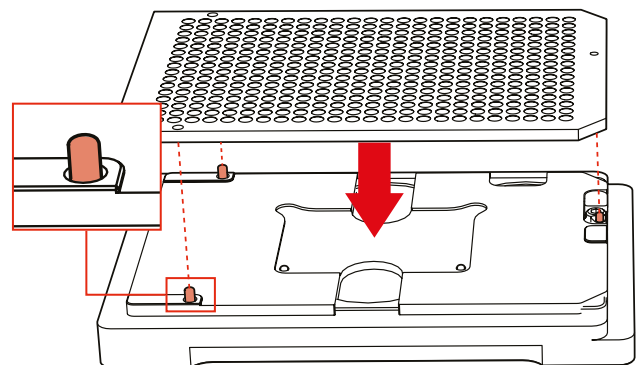

- Insert the Bruker MTP 384 target onto the 3 protruding pins on the adapter and press down firmly, so that the slide is lying flat on top of the adapter.

PICKING TO MALDI-TOF SLIDES OVERVIEW

4

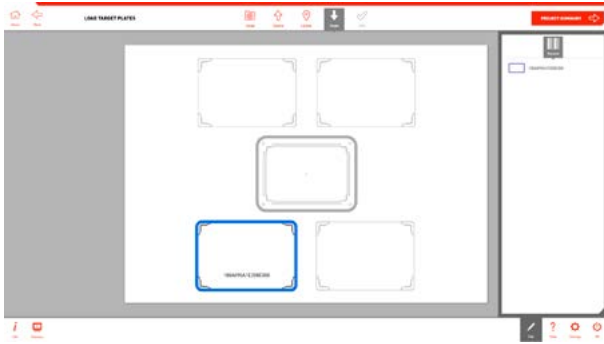

5

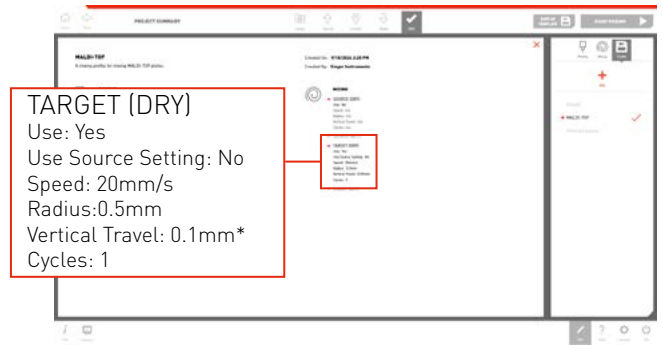

*Min value, should not be set lower.

- As with the other target plate types, the Bruker targets can be renamed. Use the *Rename Option* in the edit menu to scan a barcode or manually add a name to your targets. Click the *Project Summary* → button to continue with the workflow.

- The MALDI-TOF profile should be selected from the profile menu. PIXL will apply a dry mix on the target.
- NOTE: Optimum settings are shown above however these can be adjusted in the mixing menu.

6

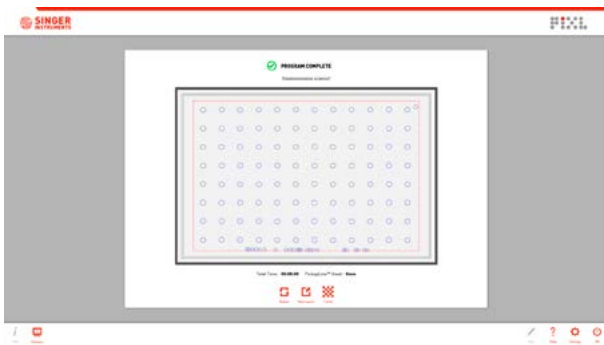

7

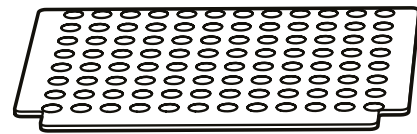

- The rest of the workflow will be the same as steps 17-21 of the *Random Colony Picking Workflow* section (P24).
- Once the pinning routine has finished, you will be presented with the summary screen. Use the Repeat/ Export options or press Finish to return to the main menu.

- Use the diagrams below as a helpful guide to remove the target from the adapter.
- Once removed the pinned Bruker target can then be used as part of a downstream MALDI-TOF workflow.

Bruker MBT 96 Slide

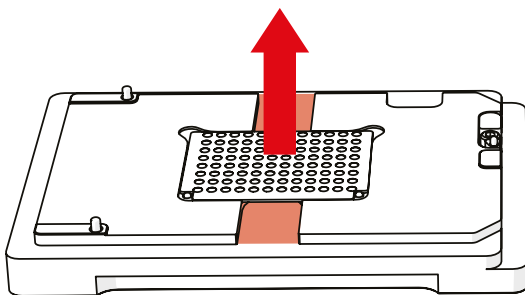

- Hold the slide from the central channel and pull up carefully to remove the target from the adapter.

Bruker MTP 384 Slide

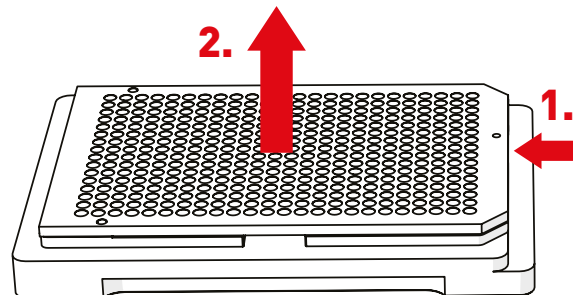

- Hold the target and press in the side latch (1). Carefully pull up to remove the target from the adapter (2).

FLUORESCENCE

The PIXL allows you to add fluorescence to your workflow with several different lighting and filter options.

Let's take a look! Click *Run Workflows* then select *Random Colony Picking*.

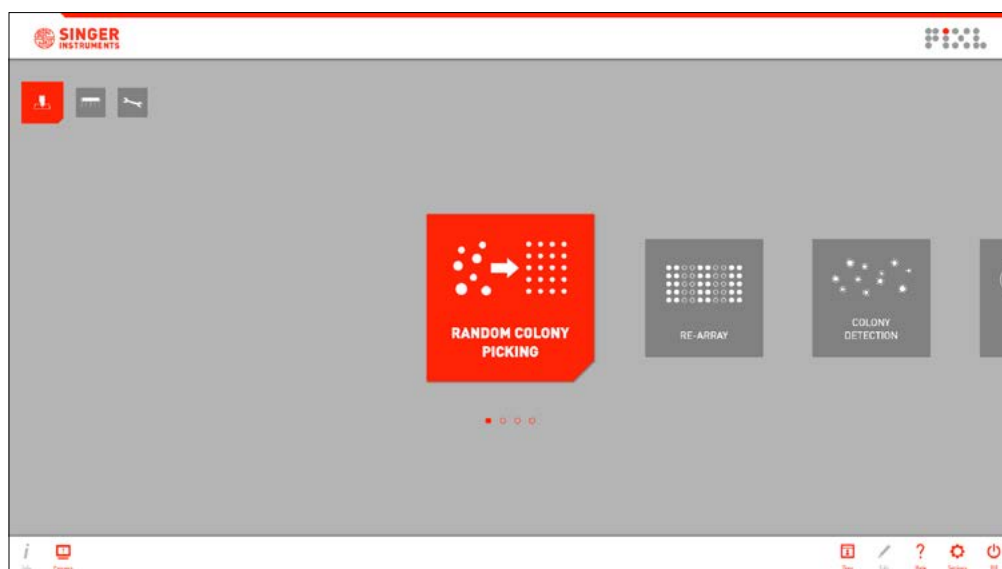

FLUORESCENCE OVERVIEW

1

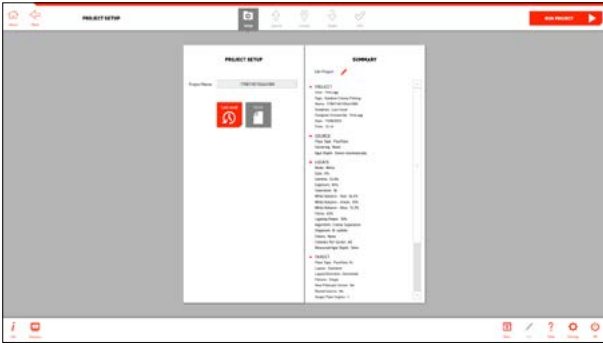

- Begin the workflow as normal following the steps as detailed in the Random Colony Picking section.

2

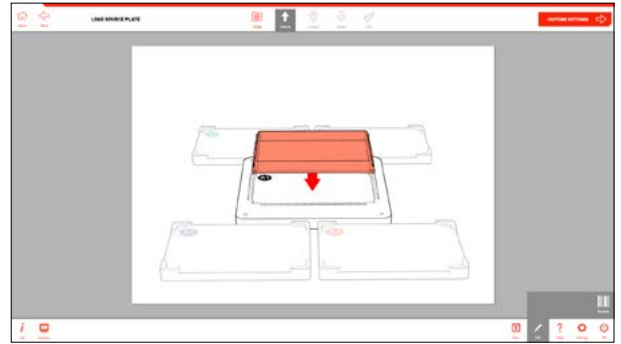

- At the Load the Source Bay screen, insert the required filter into the camera adapter.

3

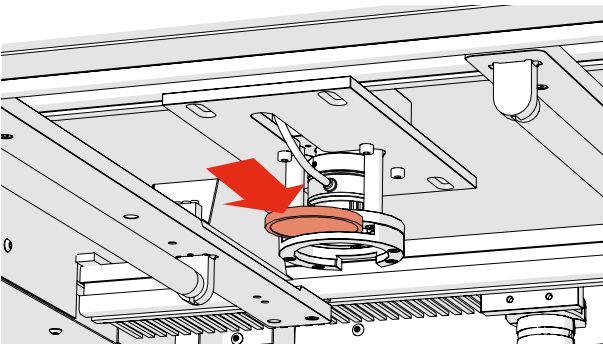

- The camera adapter can be found directly below the camera.

3

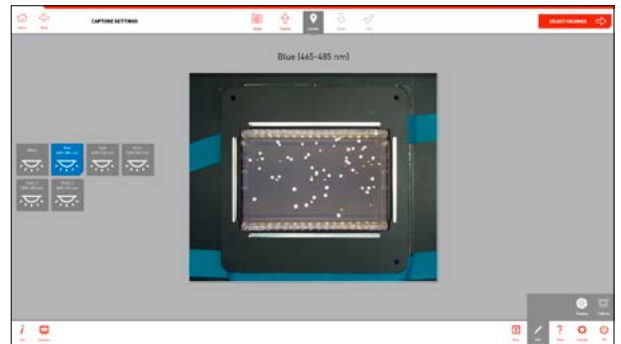

- When you get to Capture Settings, pick the required lighting condition that will excite your colonies.

LIGHTING QUICK REFERENCE

- Available lighting options in PIXL and their corresponding wavelength.

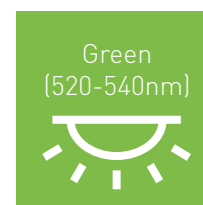
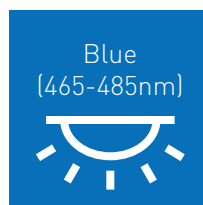
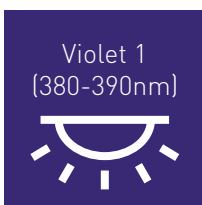

MAINTENANCE MENU

The PIXL software gives you detailed, animated instructions for all maintenance tasks, but this section also includes some step-by-step instructions as an offline reference.

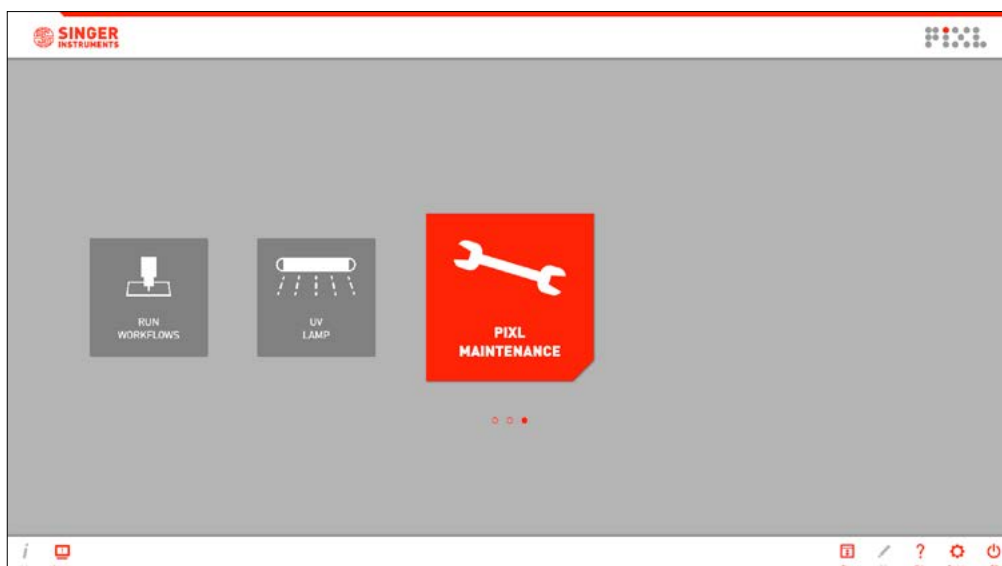

REPLACE PICKUPLINE™

1

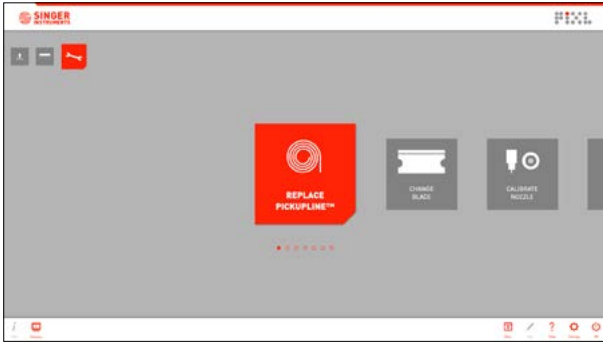

- In the Maintenance Menu, select the *Replace PickupLine* option and follow the on-screen instructions.

2

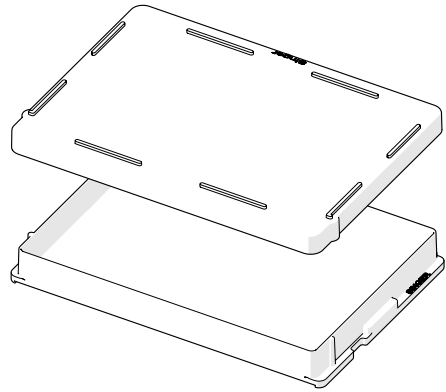

- If you're mid run, place lids on any plates in the PIXL.

3



- Follow all door prompts while the PIXL moves the arm into position.
- **NOTE:** The door will always close when the PIXL has to move a component.

4

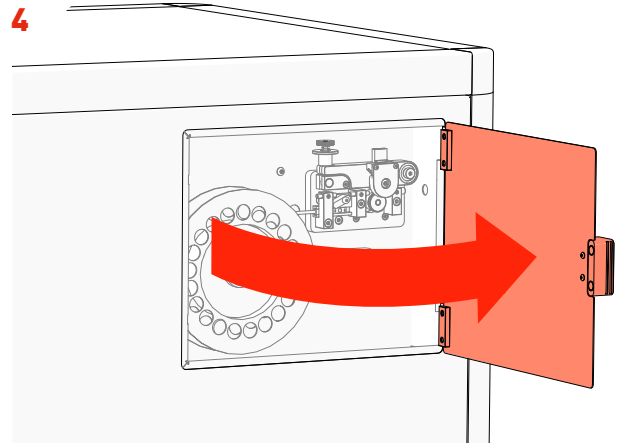

- Open the *PickupLine™ Compartment*.

5

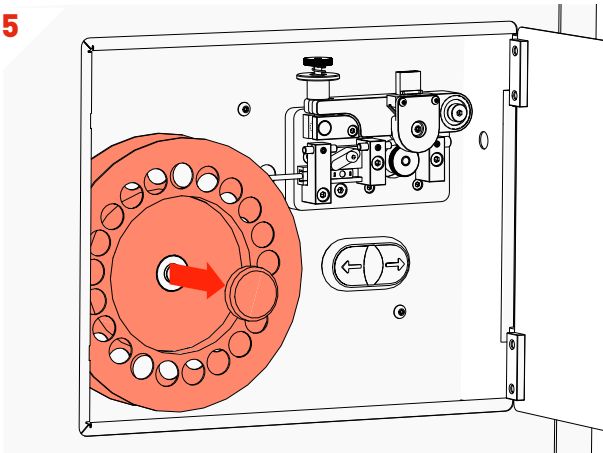

- Cut the remaining *PickupLine™* from the reel.
- Remove the magnetic *Reel Cap Cover*.
- Remove the empty *PickupLine™ Reel*.

6

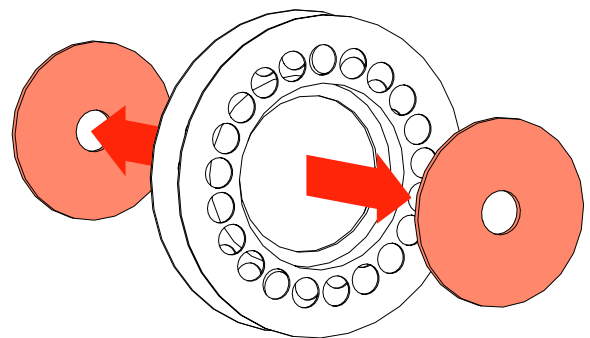

- Remove the *Reel Backing Plates* from the empty reel.

REPLACE PICKUPLINE™

7

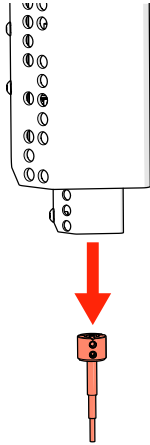

- In the main cabinet, gently remove the *Kinematic Nozzle*. The nozzle is connected magnetically, gently pull holding it by the black top.
- **WARNING: May be hot.**

8

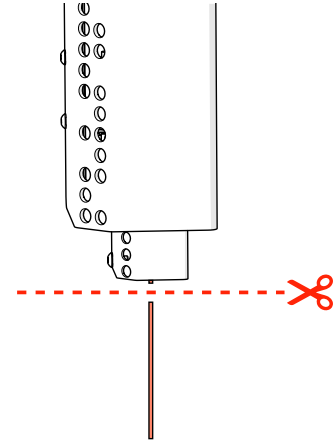

- Trim the remaining *PickupLine™* and dispose.
- **WARNING: Failure to trim the end of the PickupLine™ may clog the machine.**

9

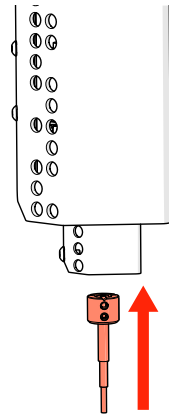

- Reattach the *Kinematic Nozzle* to the *PinPoint™ Picking Arm*.
- **NOTE:** Ensure the screw is facing forwards.

10

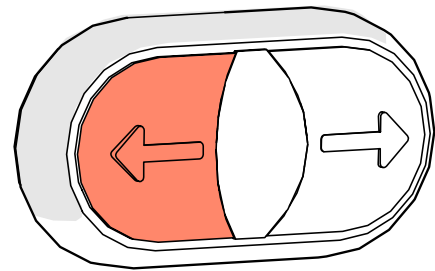

- Hold the *PickupLine™ Retract Button* to removed the leftover *PickupLine™*.

11

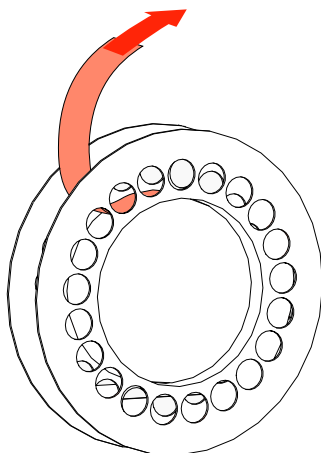

- Remove the new *PickupLine™ Reel* from it's sterile packet and dispose of the *Securing Tape/Velcro*.

12

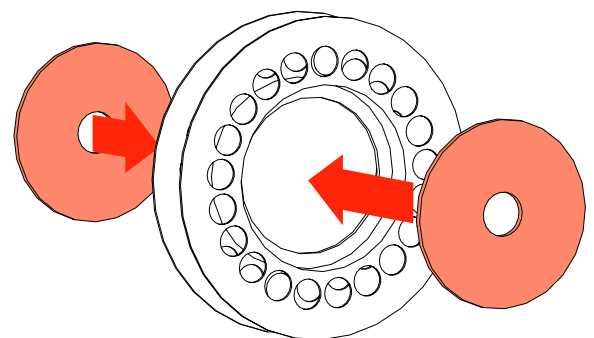

- Fit the *Reel Backing Plates* into new the *PickupLine™ Reel*.

REPLACE PICKUPLINE™

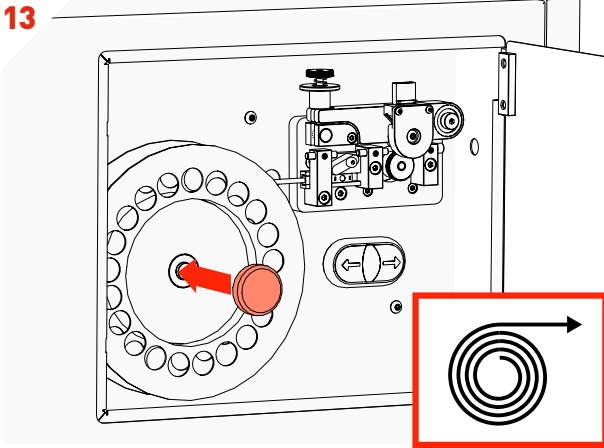

- Fit the new *PickupLine™* Reel ensuring it feeds in a clockwise direction.
- Replace the *Reel Cap Cover*.

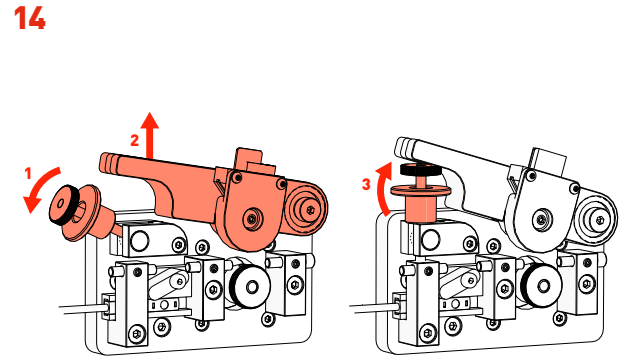

- Carefully lift the *Tension Lever* and rest it on the *Spring Catch* as shown.

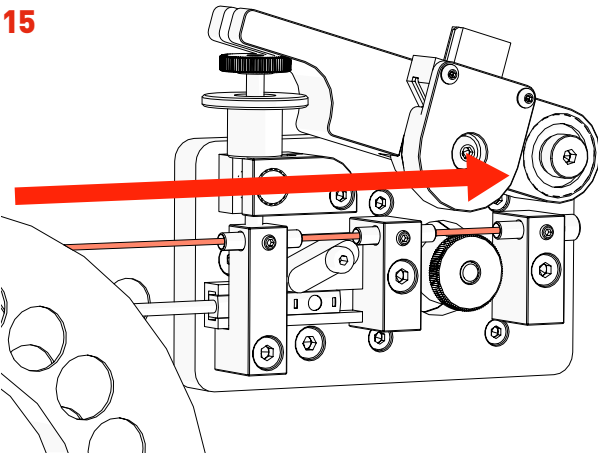

- Gently feed the *PickupLine™* by hand through the 3 *Entry Guides*. The *PickupLine™* is sterilised at the nozzle but for extra sterility gloves should be worn.
- If you meet resistance, pull back slightly and re-feed.

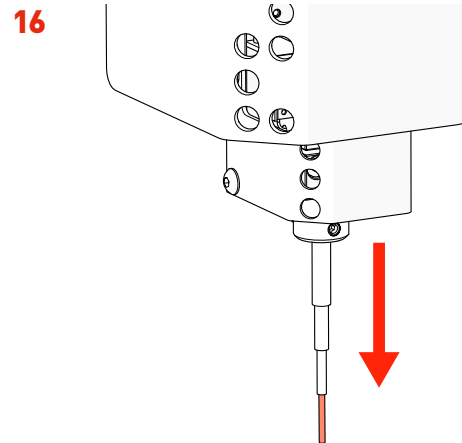

- Feed the *PickupLine™* until it protrudes 10mm from the *Kinematic Nozzle*.

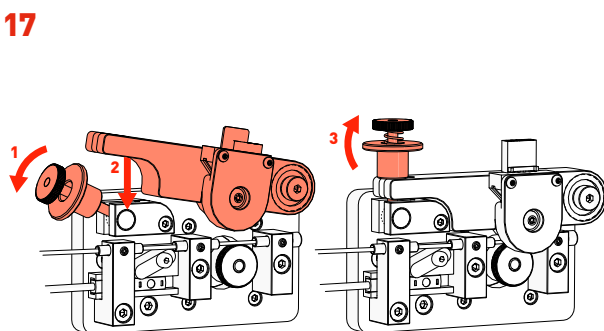

- Reset the *Tension Lever*.

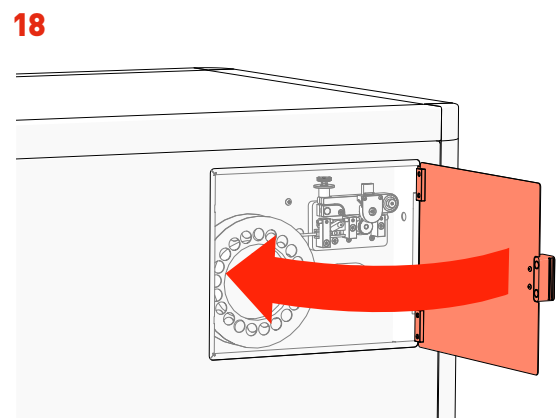

- Close the *PickupLine™* Compartment.

REPLACE PICKUPLINE™ / CHANGE BLADE

19



- Press Close Door to close the Main door while the PIXL returns the arm to its home position. You'll then be returned to the maintenance screen.
- **NOTE:** The door will always close when the PIXL has to move a component.

1



- On the maintenance menu, select *Change Blade*.
- Follow the on-screen instructions.

2



- Follow all door prompts while the PIXL moves the cleaver to its open position.
- **NOTE:** The door will always close when the PIXL has to move a component.

3

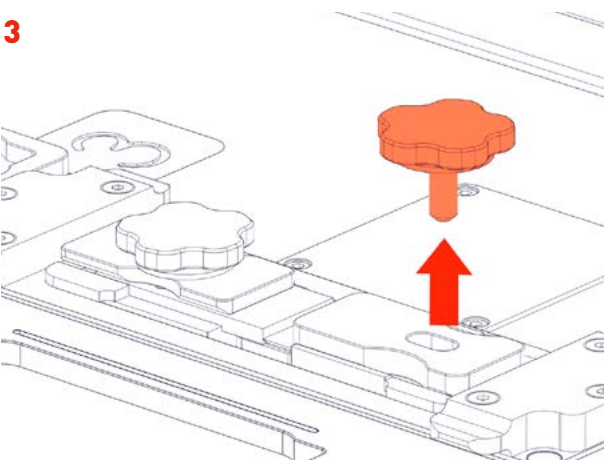

- Unscrew and remove blade thumbscrew.
- **NOTE:** The thumbscrew is magnetic and can be used later to safely pick up the blade.

4

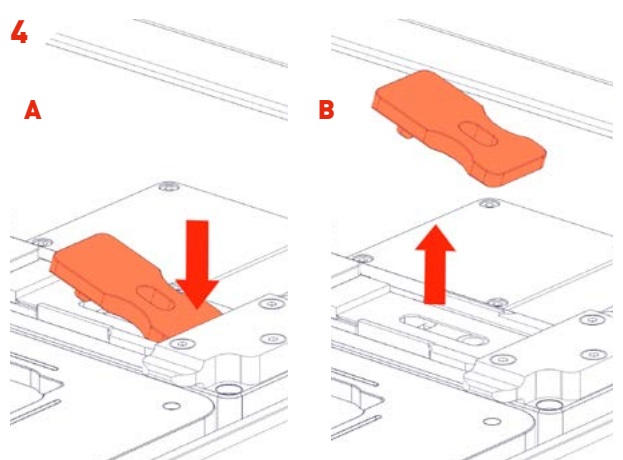

- Press the back of the blade clamp plate to unsecure it (A) and then remove (B).

CHANGE BLADE

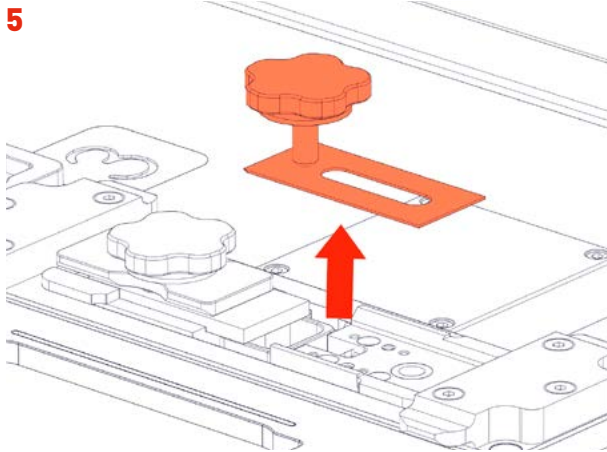

- Use the thumbscrew magnet to safely remove and dispose of the old blade.
- **WARNING: Blade is sharp! Handle with care.**

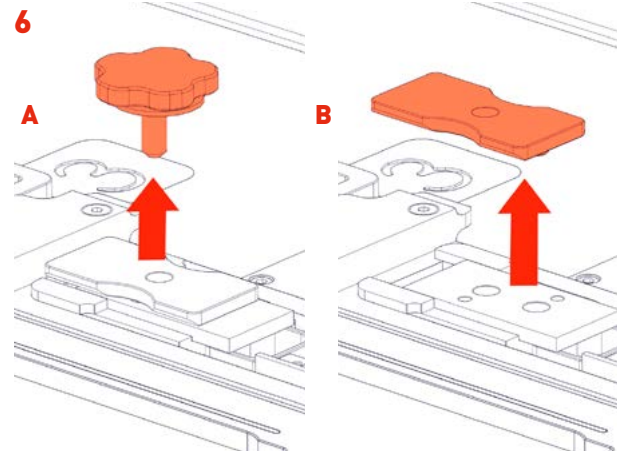

- Unscrew and remove the anvil thumbscrew (A).
- Remove the anvil clamp plate (B).

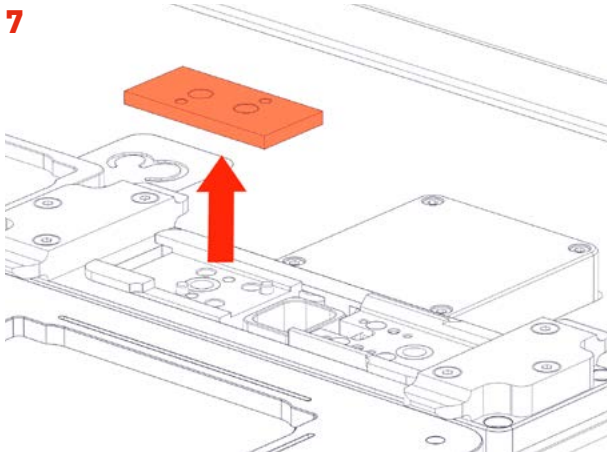

- Remove the old anvil and dispose.

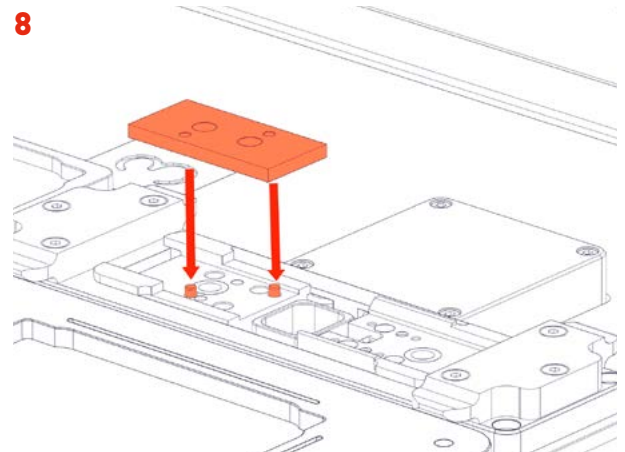

- Install the new anvil.
- Line up the base dowels with the holes in the anvil and press down firmly.

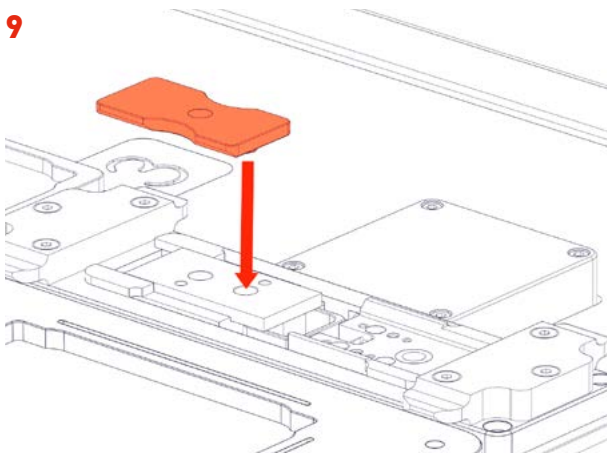

- Place the anvil clamp plate over the anvil, lining up the clamp's dowel with the front hole of the anvil as shown.

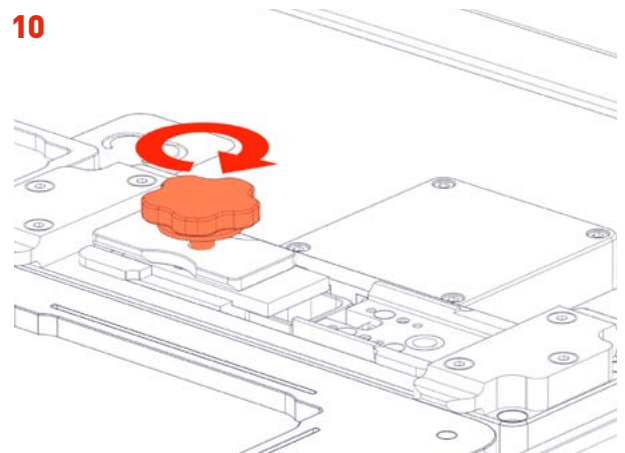

- Secure the anvil and clamp plate by fully tightening the thumbscrew clockwise.

CHANGE BLADE

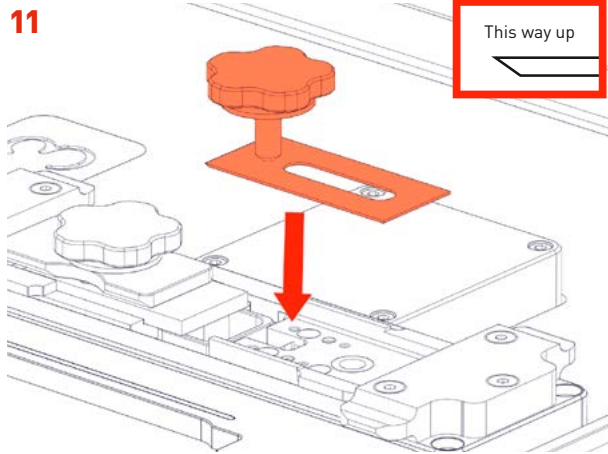

- Carefully place the blade into the blade bay and slide forward to touch the anvil.
- **WARNING: Blade is sharp! Use the thumbscrew magnet for safety.**

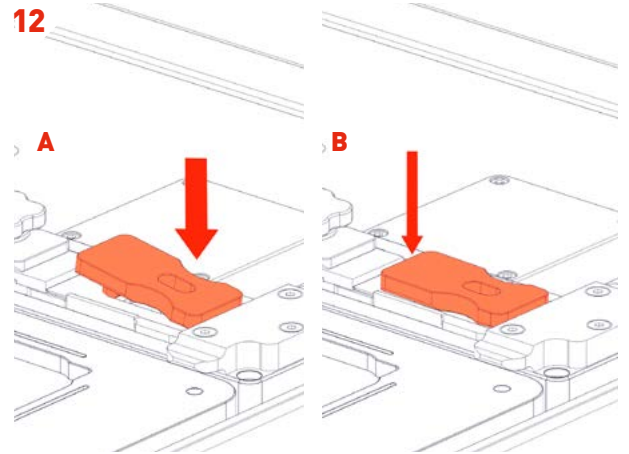

- Place the blade clamp over the blade (A) and press the dowel into the gap in the blade (B).

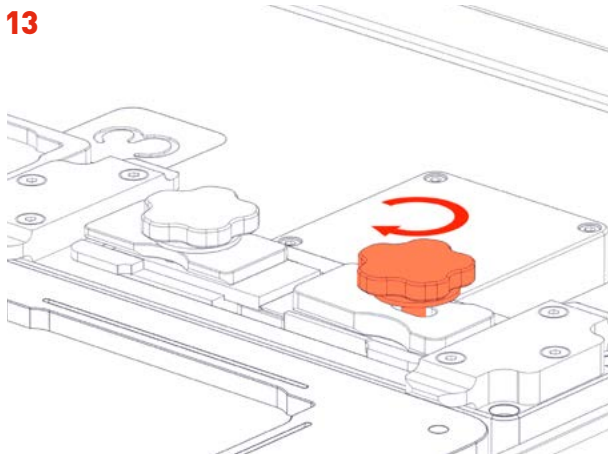

- Secure the blade and clamp in place by fully tightening the thumbscrew clockwise.
- **NOTE:** Ensure the thumbscrew is fully tightened.
- Click *Done* to return to the maintenance menu.



- Press Close Door to close the Main door while the Cleaver performs a couple of test cuts. You'll then be returned to the maintenance screen.
- **NOTE: The door will always close when the PIXL has to move a component.**

REPLACE NOZZLE

1

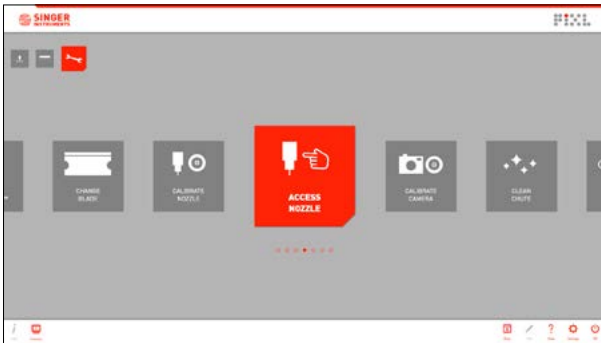

- On the maintenance menu, select *Access Nozzle*.

2



- Follow all door prompts while the PIXL moves the arm into position.
- **NOTE:** The door will always close when the PIXL has to move a component.

3

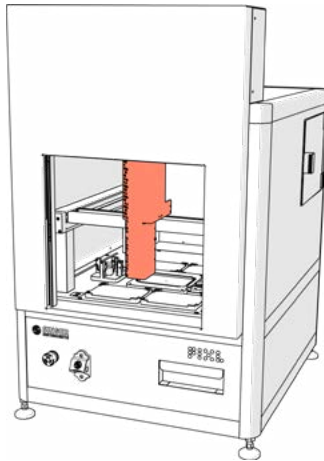

- The nozzle will move to the front of the machine to allow access.

4

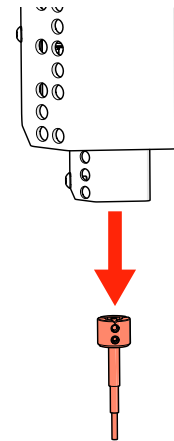

- Gently pull the *Kinematic Nozzle* from its securing magnet. The nozzle is autoclavable.
- **WARNING:** The nozzle may be hot!

5

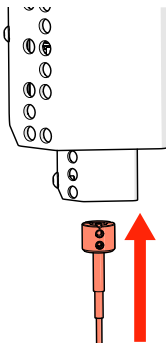

- Attach the new/autoclaved *Kinematic Nozzle* back onto the securing magnetic, being sure to feed any PickupLine™ through the nozzle in the process.
- Ensure the screws are at the front of the nozzle.

6



- Press Close Door to close the Main door while the PIXL calibrates the Kinematic Nozzle. You'll then be returned to the maintenance screen.
- **NOTE:** The door will always close when the PIXL has to move a component.

CALIBRATE NOZZLE

1

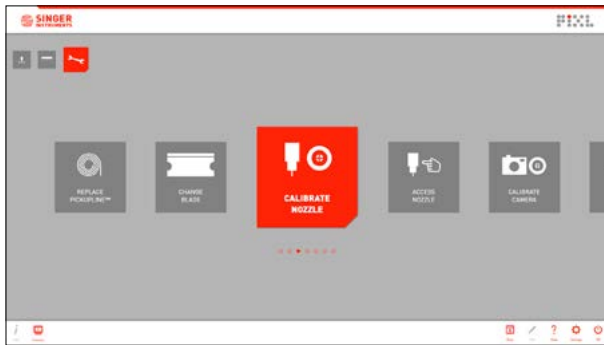

2



- To ensure picking accuracy, the nozzle needs to be calibrated any time it has been removed.
- On the maintenance menu, select *Calibrate Nozzle*.

- Follow all door prompts while the PIXL moves the arm into position.
- **NOTE:** The door will always close when the PIXL has to move a component.

3

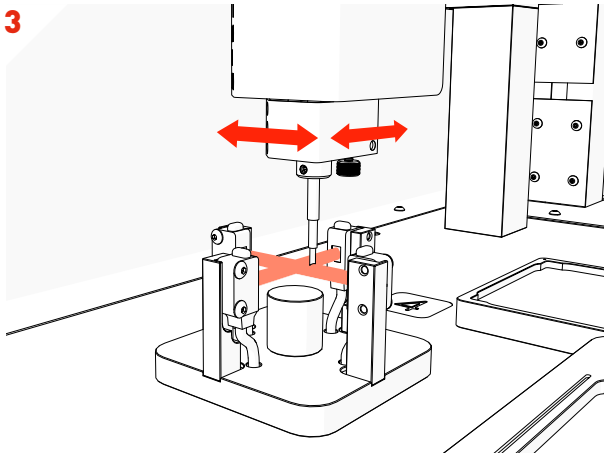

- Follow the on-screen instructions as the nozzle calibrates on the calibration plate.
- Once complete, you will be returned to the *Maintenance Menu*.

CALIBRATE CAMERA

1

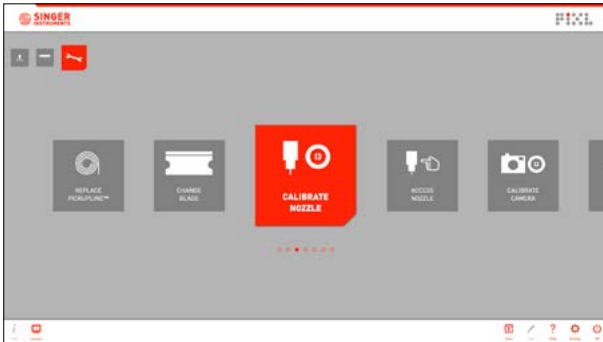

- On the maintenance menu, select *Calibrate Camera*.
- Ensure you have removed any plates from the PIXL, and make sure there is a source plate bay loaded.

2



- Follow all door prompts while the PIXL sets up the camera.
- **NOTE:** The door will always close when the PIXL has to move a component.

3

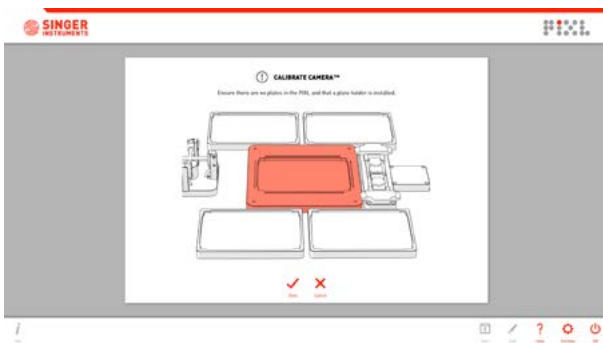

- Click *Done* and the camera will calibrate.
- Once complete, you will be returned to the *Maintenance Menu*.

CLEAN WASTE CHUTE

1

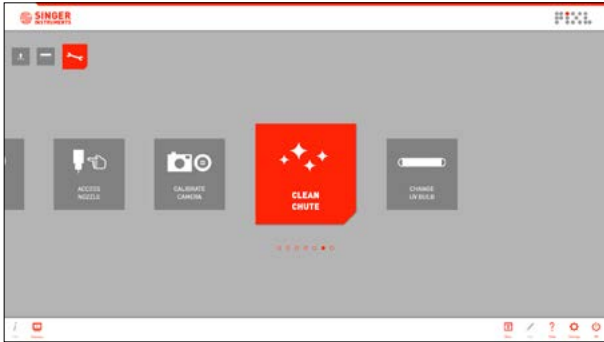

- On the maintenance menu, select *Clean Chute*.

3

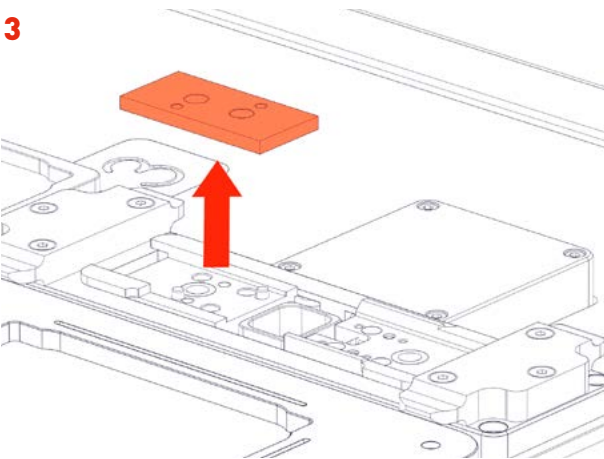

- Remove the blade and anvil as shown on pages 49-51, steps 2-6.

5

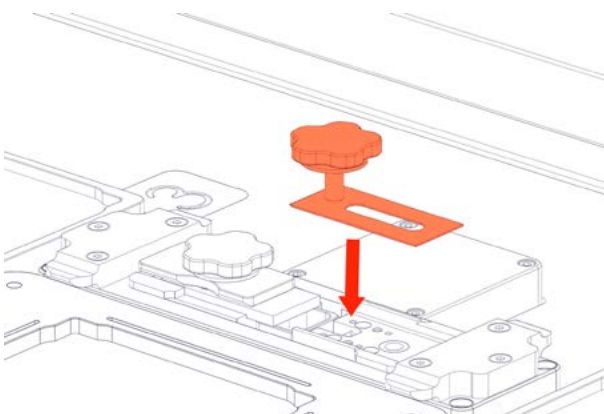

- Reinstall the blade and anvil as shown on page 50, steps 7-12.

2



- Follow all door prompts while the PIXL moves the cleaver to its open position.
- **NOTE:** The door will always close when the PIXL has to move a component.

4

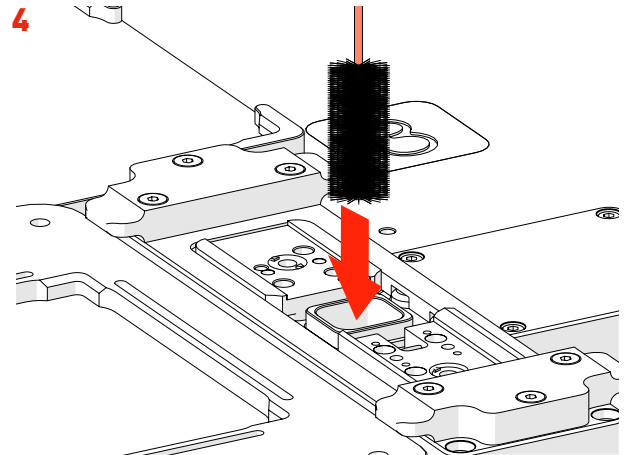

- The waste chute comes into contact with used PickupLine™. Use a bottle cleaner and ethanol to clean the inside of the chute.

6



- Press Close Door to close the Main door while the Cleaver performs a couple of test cuts. You'll then be returned to the maintenance screen.
- **NOTE:** The door will always close when the PIXL has to move a component.

CHANGE UV BULB

1



- On the maintenance menu, select *Change UV Bulb*.

2



- Follow all door prompts while the PIXL moves the cleaver to its open position.
- **NOTE:** The door will always close when the PIXL has to move a component.

3

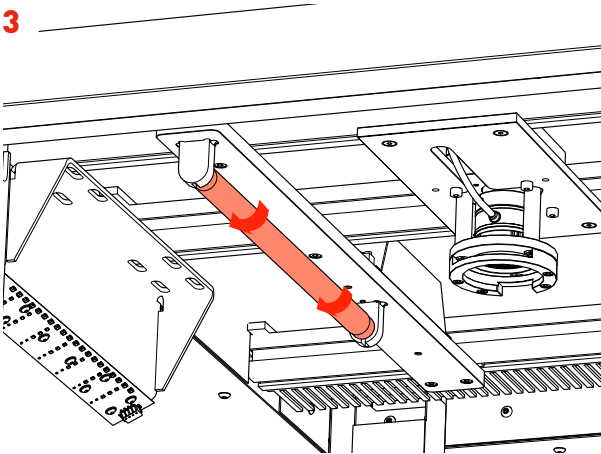

- Rotate the *UV Bulb* that you want to change 90 degrees, in either direction, until you hear a click.
- **NOTE:** Wear gloves.

4

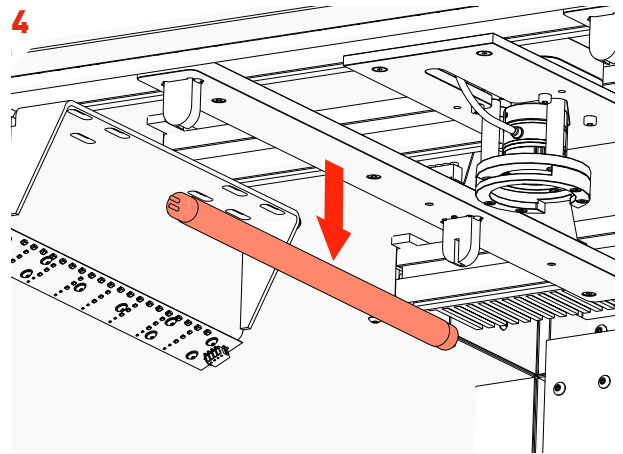

- Carefully pull the old *UV Bulb* down and remove.

5

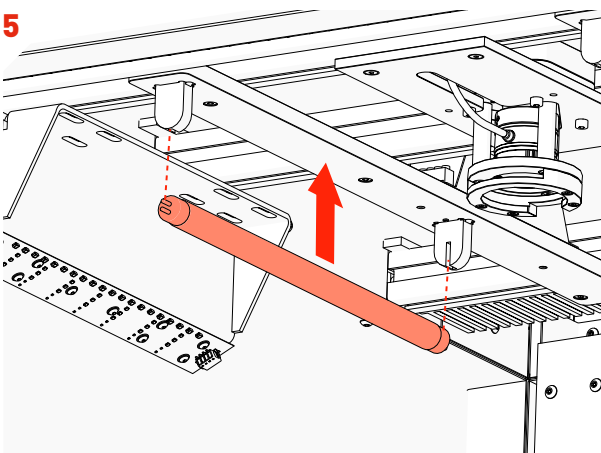

- Slot the new *UV Bulb* into the *UV Socket Grooves* and rotate the new UV Bulb 90 degrees, in either direction until you hear a click.

6



- Press *Close Door* to close the Main door and return to the Maintenance Menu.

BEST PRACTICE

We want you to have a trouble-free time with your PIXL so we've assembled some handy hints, tips and troubleshooting answers to keep you on the straight and narrow.

PLATES

SOURCE PLATES

The PIXL accepts the following source plate formats:

- 90 mm Petri Dishes
- 150 mm Petri Dishes
- 120 mm Square Petri Dishes
- Rectangular PlusPlates™

TARGET PLATES

The PIXL accepts the following target plate formats:

- 96 Multiwell
- 96 Well PCR
- 384 Multiwell
- 384 Well PCR
- 96 Deep Well
- Rectangular PlusPlates™
- 384 Deep Well

LOADING PLATES

When loading your source plate, ensure that you have the correct source bay installed.

Source bays fit magnetically, simply lift the current source bay out and replace it with the correct source bay for your plate type, as shown in *Figure 1*.

Each target bay is colour-coded and numbered. The software will show you which bays to load your plates into. A1 is in the top left corner of each bay, *Figure 2*.

NOTE: Remove lids before loading plates into PIXL.

PLATE DIMENSIONS

All source and target plate types have default dimensions in the PIXL software. You can view these when on the *Source and Target Stages*, in the *Edit Menu*, under the *Dimensions Tab*, as shown in *Figure 3*.

If the plates you plan to use are drastically different from the default dimensions, please contact technical support and we'll add your specific plate type to the drop down list:

technicalsupport@singerinstruments.com

Figure 1

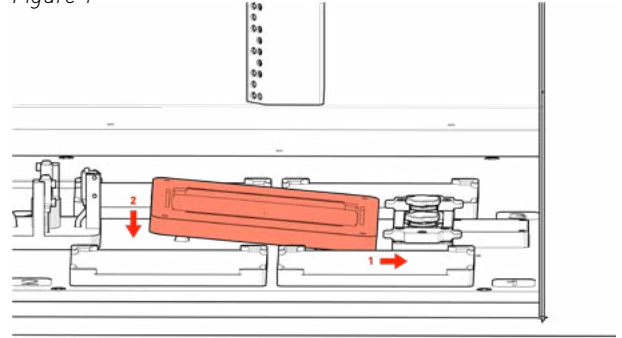

Figure 2

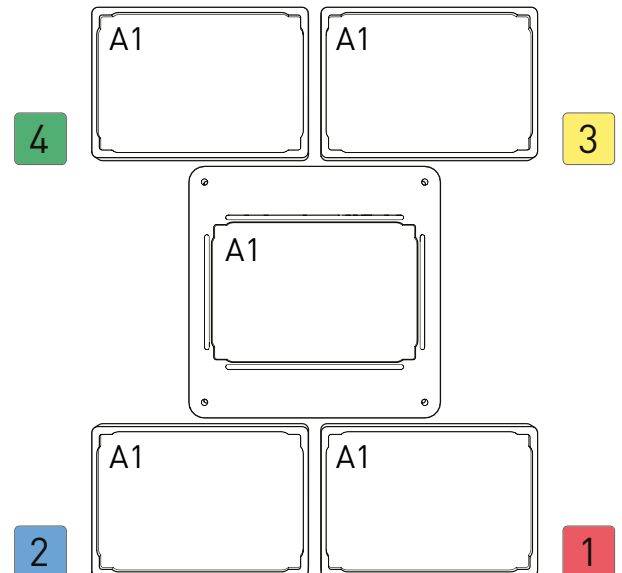
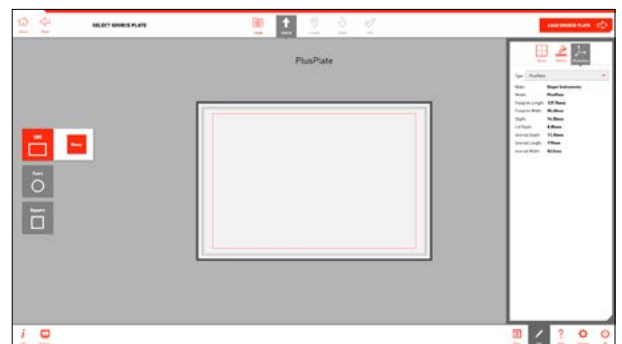

Figure 3



CLEANING

WASTE CHUTE

The waste chute comes into contact with used PickupLine™. Use a bottle cleaner, with ethanol or an appropriate cleaning agent, to clean the chute, as shown in *Figure 4*.

To gain access to the waste chute, you will need to remove the cleaver assembly. For full instructions see page 52.

DUMP DRAWER

The dump drawer collects all of the used tips at the bottom of the waste chute *Figure 5*.

The dump drawer can also be autoclaved.

KINEMATIC NOZZLE

To help ensure sterility, the kinematic nozzle is autoclavable. Spare nozzles are also available to reduce downtime during autoclaving.

UV

The UV lamp program is located on the home screen *Figure 6*. The UV lamp can be set to run for up to 60 minutes to sterilise the main cabinet *Figure 7*. For complete sterility, we recommend each day giving the inside of the machine a wipe down with ethanol and running a small UV routine.

Figure 4

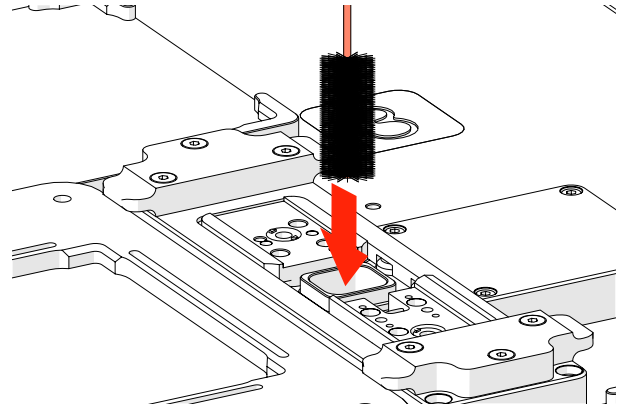

Figure 5

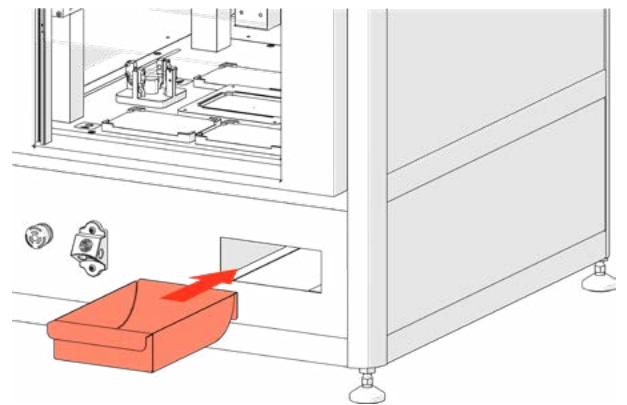

Figure 6

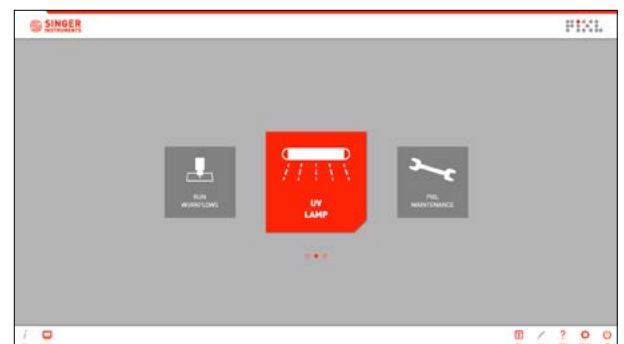

Figure 7



FILTERS

USING FILTERS

PIXL accepts standard 50mm filters. You can easily switch between all of your favourite lighting conditions to filter for the markers that interest you.

Insert your filters at the locate stage while you have the live preview image on screen, *Figure 8*.

The filters are manually inserted in front of the CMOS camera, into the *Filter Tray*, as shown in *Figure 9*.

Figure 8

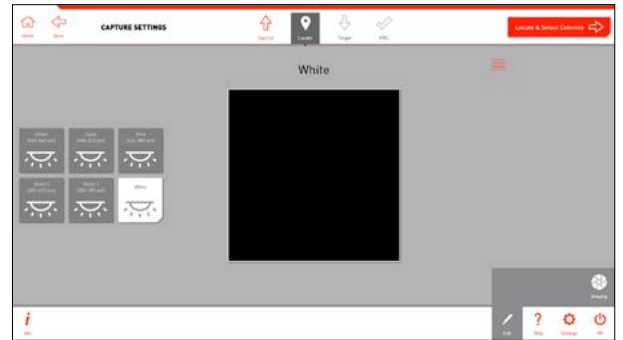
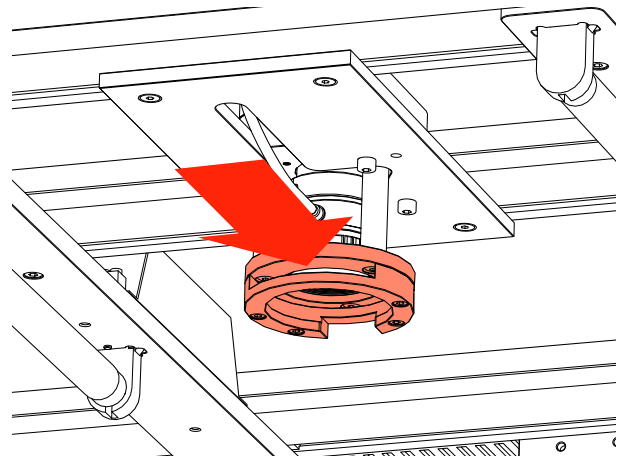

Figure 9



PROJECT TEMPLATES

1

- You can save projects as templates at the *Project Summary* stage by clicking the *Save as Template* button.



2

- Name your template and add a quick description then click *Save*.

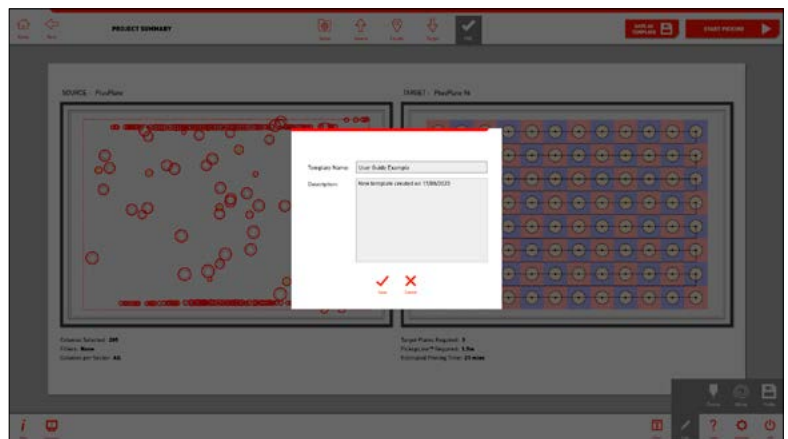

3

- At the *Project Setup* stage you can see all project templates.
- When you select a template, clicking *Run Project* → will take you to the plate loading stages then a project summary.
- Clicking *Edit Project* will allow you to step through a workflow using the template as a base.

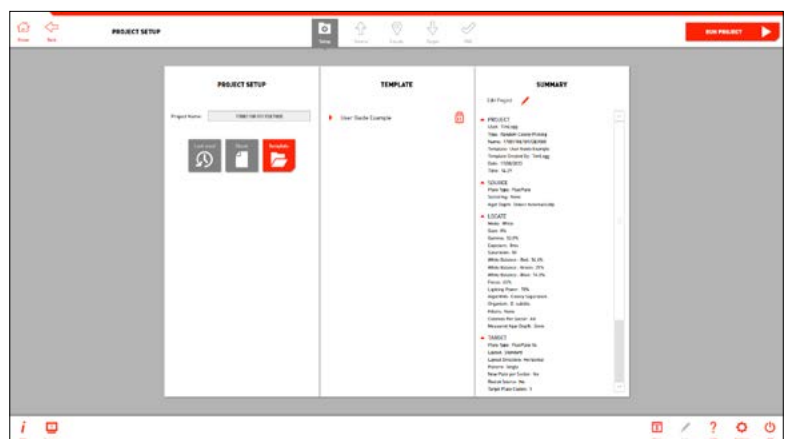

PINNING AND MIXING PROFILES

1

- You can save your pinning and mixing settings as a profile to be recalled for any future projects using the *Profile Options* in the edit menu.
- Click *Add* to save your current pinning and mixing settings.

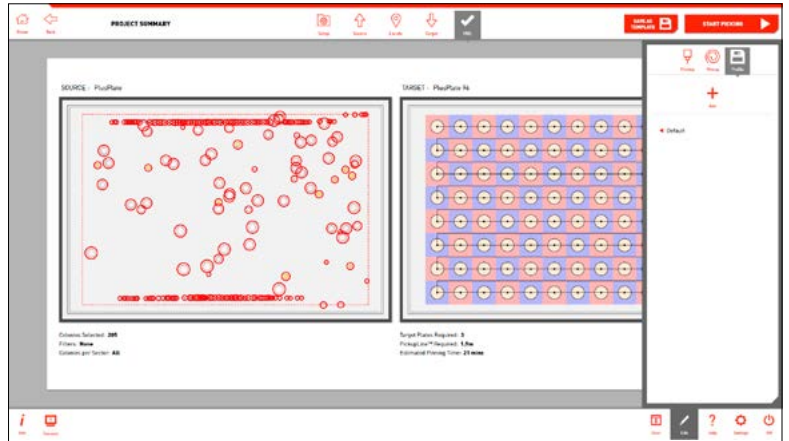

2

- Name your profile and add a quick description then click *Save*.

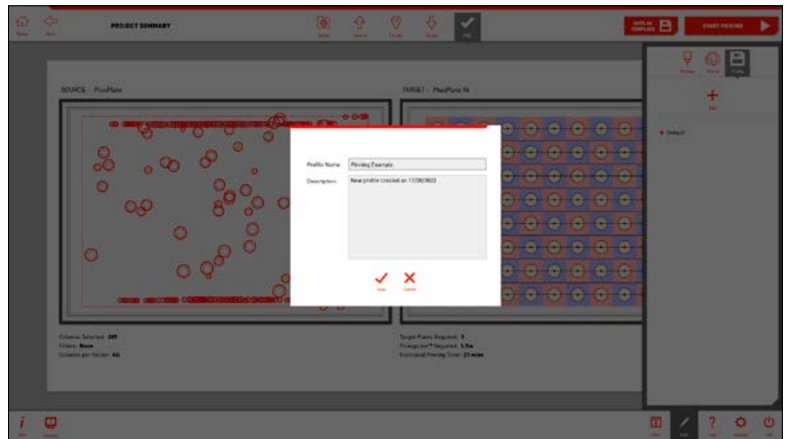

3

- Click on any of the saved profiles to see a summary of the pinning and mixing options.
- Click the tick icon to select that profile for your current project.



HELP - SEE HOW VIDEOS

1

- When you select an action in the maintenance menu you are guided through the process with step by step animations.
- You can access these videos at any time in the *Help Menu*.

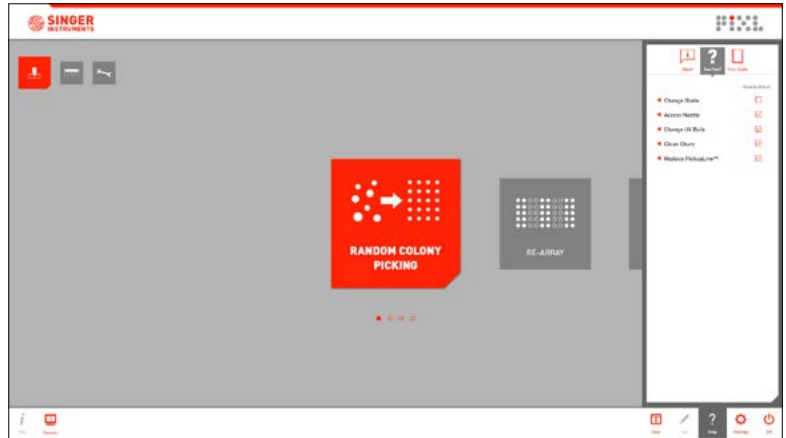

2

- Click on an item from the list to see the step by step instructions.

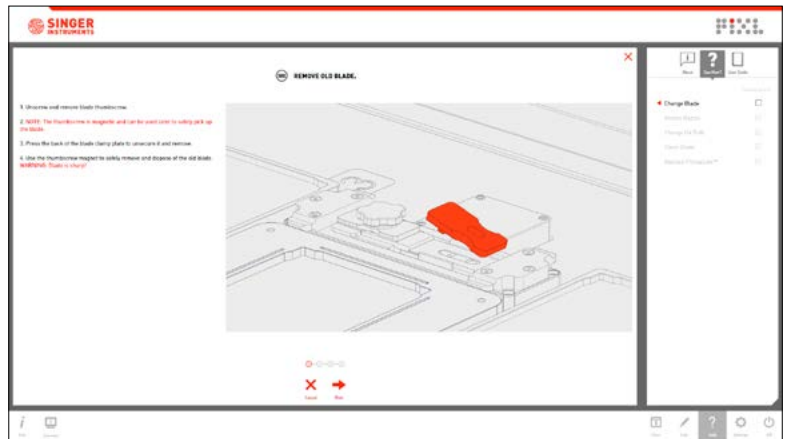

SOFTWARE ICONS

HOME SCREEN



RUN WORKFLOWS
Takes you to the PIXL Workflows Menu.



UV LAMP
Allows you to run the UV lamp for a specified period of time.

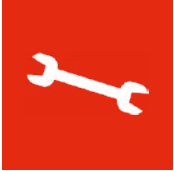

PIXL MAINTENANCE
Takes you to the PIXL Maintenance Menu.

WORKFLOWS MENU

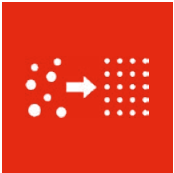

RANDOM COLONY PICKING
Starts a new Random Colony Picking routine.

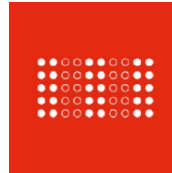

RE-ARRAY
Starts a new Re-array routine.

MAINTENANCE MENU



REPLACE PICKUPLINE™
Allows you to change the PickupLine™ reel. On-screen instructions are provided.



CHANGE BLADE
Allows you to change the cleaver blade and anvil. On-screen instructions are provided.



CALIBRATE NOZZLE
Automatically calibrates the kinematic nozzle to ensure picking accuracy.

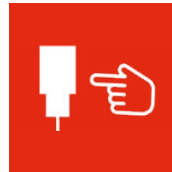

ACCESS NOZZLE
Brings the kinematic nozzle to the front of the machine. From here you can remove for autoclaving.



CALIBRATE CAMERA
Automatically calibrates the camera to ensure colonies are located accurately.





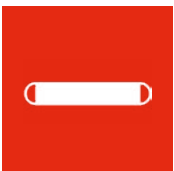

CLEAN CHUTE
Allows you to remove the cleaver assembly to give access to the waste chute for cleaning.











CHANGE UV BULB
Allows you to change the UV bulbs. On-screen instructions are provided.

SOFTWARE ICONS





BOTTOM BAR (COMMANDS)

	PROJECT INFO Shows a full project summary so far.		EDIT MENU Edit stage-specific project options.
	HELP MENU Opens the PIXL help menu.		SOFTWARE SETTINGS Run the UV lamp for a specified period of time.
	OFF Switch users, exit software, reset PIXL, or shutdown PIXL.		

TOP BAR (NAVIGATION)

	HOME Takes you back to the home screen.		BACK Takes you back to the previous stage.
	PROJECT SETUP Takes you back to the project setup stage. Icon is grey when disabled.		SOURCE Takes you back to the source stage. Icon is grey when disabled.
	LOCATE Takes you back to the locate stage. Icon is grey when disabled.		TARGET Takes you back to the target stage. Icon is grey when disabled.
	PIXL This is the summary stage — the last stage before the pinning routine starts.		NEXT STAGE Takes you on to the next stage.

EDIT MENU

	SECTORS Found on the source stage. Split your source plate into sectors.		DIMENSIONS Found on the source and target stage. Shows the default dimensions of each plate type.
	RENAME Found on the plate loading stages. Scan barcodes or rename plates manually.		IMAGING Found on the locate stage. Allows you to edit the camera settings.

SOFTWARE ICONS



FILTERS

Found on the locate stage.
Filter your selected colonies by proximity, colour, intensity, circularity, and area.



SELECTION

Found on the locate stage.
Further refine your colony selection for picking.



ALGORITHM

Found on the locate stage.
Optimise the colony detection for specific organisms.



PICTURE OPTIONS

Found on the locate stage.
Choose how to display the source plate.



LAYOUT

Found on the target stage.
Exclude rows and columns on your target plates.



REPLICATES

Found on the target stage.
Select how many copies of each colony to pin.



ADDITIONAL PLATES

Found on the target stage.
Select how many copies of each target plate to make.



PINNING

Found on the PIXL stage. Adjust the pinning options such as speed or well clearance.



MIXING

Found on the PIXL stage. Turn on and adjust the mixing options such as speed or number of cycles.



PROFILE

Found on the PIXL stage. Save pinning and mixing options as a profile.

SELECTION LAYOUT OPTIONS



SORT ALPHABETICALLY

Sort options alphabetically.



SORT BY LAST USED

Sort options by last used first.



SORT BY POPULARITY

Sort options by most popular options first.



GRID LAYOUT

Display options in a grid



CAROUSEL LAYOUT

Display options in a carousel.



RESET SLIDER

Reset slider to the default value.



EXPAND SLIDER

Expand slider to a full screen view.

TROUBLESHOOTING

PROBLEM

Plate guides could not be detected

The PickupLine™ hits the top plate as the picking arm moves between positions

The PIXL is missing colonies.

Blades wear down quickly.

SOLUTION

Ensure that a source plate holder is installed into the PIXL.

Ensure that the plate dimensions in the software match that of the plate being used. If the plate type is unsupported please contact technicalsupport@singerinstruments.com and we'll make a new dimensions file for the plate.

Ensure that the nozzle has been calibrated by running the 'Calibrate Nozzle' routine in the software. Ensure that the Detect automatically' option is selected for 'Agar Depth'.

Please correctly follow instructions for changing the blade on page 42.



For more support resources visit
bit.ly/PIXLhelp

CREATING A RE-ARRAY FILE

THE BASICS

So, you're looking to get stuck into re-arranging - awesome.

Re-Array mode allows you to pick colonies from a source plate and place (or pin) them onto a target plate, in a completely customisable pattern. You can use several different plate types and either traditional well locations or exact coordinates.

What this really means is, you can pick from anywhere to anywhere, in almost any plate type - how cool!

So, what do we need to get started?

- A program that can export .tsv (or .csv) files; Excel and Google Sheets both work. (This is where we'll create the file)
- Which plates you want to pick from, and to. (The Source and Target)
- An idea of the locations we're pinning from and to

Got all this? Awesome.

A FULL BREAKDOWN

Step 1: Define The Plates

Let's start with a basic example. You have colonies in a 96 Multi Well Plate and you'd like to pin them to a SBS Plate. To begin, we need to define the plates. In a blank spreadsheet, starting in cell A1 lay out the plate name, type, density and role as in the diagram below.

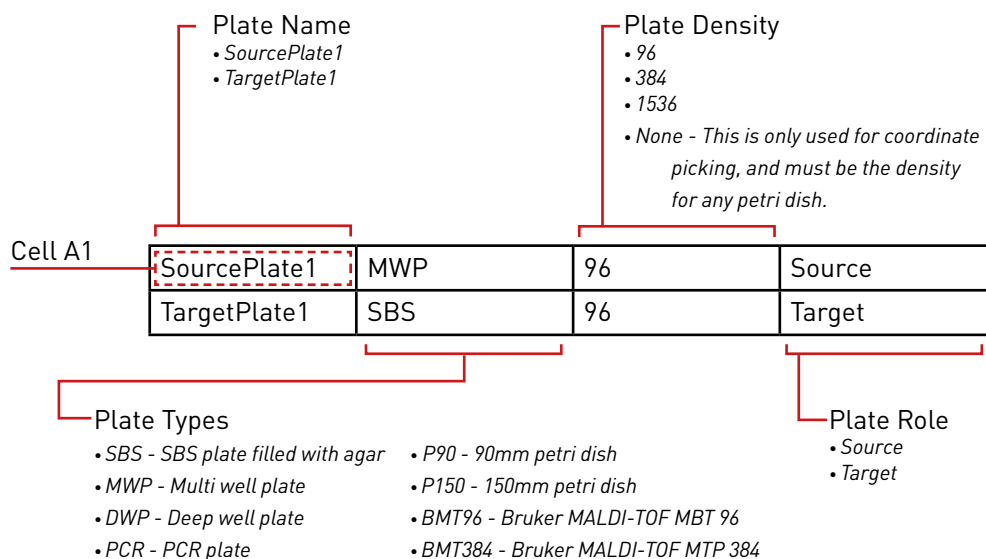

We have used arbitrary plate names above. If you place a '\$' prior to the name the plate will be given a unique ID. This name is only used within the exported data logs, so you can use anything. For simplicity, consider using '\$SourcePlate1' and '\$TargetPlate1' for ease of file creation, and PIXL will assign unique names for the export logs.

PIXL will decide which plates should go where, typically the 'Source' plate will go to the source bay, and the first target plate will go into bay 1. This is necessary as some plates are required to be in specific bays, and user defined plate locations will limit the flexibility of re-arranging. PIXL will produce instructions on where to load plates, based on the Plate Name.

Note: if you're using '\$TargetPlate1' or similar, the plate names will already be automatically generated and will not match the original input.

PLATE DIMENSIONS (OPTIONAL)

You can specify dimensions after the plate role, however, this is not needed - PIXL will run based on the standard stored dimensions for each plate type. If you have a custom dimension file or need to use one of the preset options then you can specify this in the file.

CREATING A RE-ARRAY FILE

Available plate types will appear on a drop-down menu in the Target selection screen during Random Colony Picking, in this example we are using the *Corning Costar Assay Plate*.

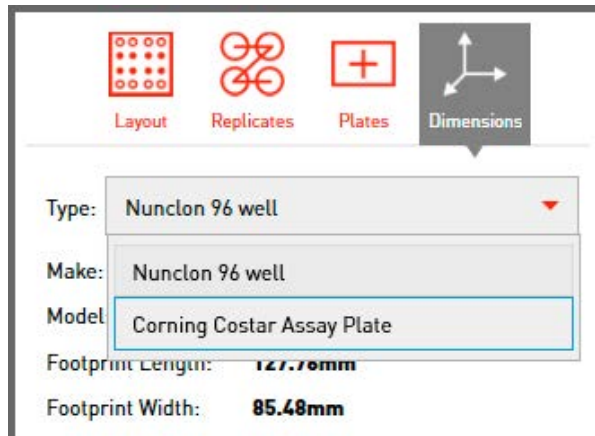

Make sure the plate name is noted exactly as it is written, add this to the empty cell to the right of the plate you want to define.

SourcePlate1	MWP	96	Source	Corning Costar Assay Plate
TargetPlate1	SBS	96	Target	

Step 2: Define The Pinning Locations

Now we've completely defined our plates, the second step is to define the pinning locations, this can be done in two ways:

Method 1. Using grid (well) references, e.g. A1, B3, H7 etc.

For this method it's important to note that the locations are written Y,X as is normal on a 96 well plate, and not a standard graph. The letters of the Y location can also be replaced with numbers, e.g. 1,1 / 2,3 / 8,7, etc.

		X											
		1	2	3	4	5	6	7	8	9	10	11	12
Y	A	A,1	A,2	A,3	A,4	A,5	A,6	A,7	A,8	A,9	A,10	A,11	A,12
	B	B,1	B,2	B,3	B,4	B,5	B,6	B,7	B,8	B,9	B,10	B,11	B,12
	C	C,1	C,2	C,3	C,4	C,5	C,6	C,7	C,8	C,9	C,10	C,11	C,12
	D	D,1	D,2	D,3	D,4	D,5	D,6	D,7	D,8	D,9	D,10	D,11	D,12
	E	E,1	E,2	E,3	E,4	E,5	E,6	E,7	E,8	E,9	E,10	E,11	E,12
	F	F,1	F,2	F,3	F,4	F,5	F,6	F,7	F,8	F,9	F,10	F,11	F,12
	G	G,1	G,2	G,3	G,4	G,5	G,6	G,7	G,8	G,9	G,10	G,11	G,12
	H	H,1	H,2	H,3	H,4	H,5	H,6	H,7	H,8	H,9	H,10	H,11	H,12

Method 2. Using Cartesian co-ordinates, e.g. -34.0,22.5 etc.

This is a more complex, but precise method of telling PIXL exactly where to pick. When using cartesian co-ordinates the centre of the plate is 0.0,0.0 as shown below. This is measured in mm. You'll need to generate coordinates for your colonies, which you can get from PIXL outputs, or potentially other plate analysis software. You can also see the approximate location coordinates of the four corner wells on a 96 well plate.

CREATING A RE-ARRAY FILE

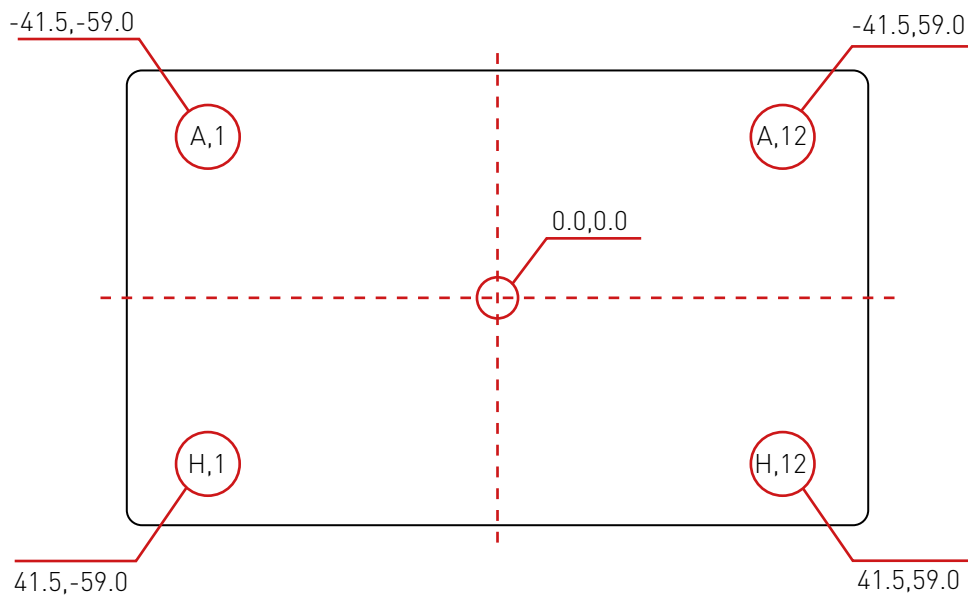

When using coordinates, you must have the plate density set to 'None' and in each coordinate you must use a decimal point; '0.0,0.0' is valid, however '0,0' is not and PIXL will interpret this as a plate location as seen in Method 1. This will lead to an error in the file.

WRITING A PINNING COMMAND

We're now ready to combine everything above into a command, continuing from the earlier example (where we set our source plate as a 96 MWP, and our target as an SBS agar plate with a density 96). We're going to pin from well A1 to the first 4 positions A1-A4.

Source Plate			Target Plate		
SourcePlate1	A	1	TargetPlate1	A	1
SourcePlate1	A	1	TargetPlate1	A	2
SourcePlate1	A	1	TargetPlate1	A	3
SourcePlate1	A	1	TargetPlate1	A	4

Plate Name
Y
X
Plate Name
Y
X

*Line Break

LINE BREAKS

Finally, a line break will define when the PickupLine is cleaved. This is the point where a line finishes and the next one starts. This allows you to control the exact function before cleaving, offering multiple picks. In the example above The PickupLine is cleaved after the target plate is pinned at location A,1.

Step 3: Combining The File & Export

We've now defined our plate types and desired picking locations, let's combine Step 1 & 2 into the final file. Your spreadsheet should look like the example below.

SourcePlate1	MWP	96	Source		
TargetPlate1	SBS	96	Target		
SourcePlate1	A	1	TargetPlate1	A	1
SourcePlate1	A	1	TargetPlate1	A	2
SourcePlate1	A	1	TargetPlate1	A	3
SourcePlate1	A	1	TargetPlate1	A	4

CREATING A RE-ARRAY FILE

Export this as tab-separated values (.tsv) or comma-separated values (.csv), a .tsv file will look like this:

SourcePlate1	MWP	96	Source		
TargetPlate1	SBS	96	Target		
SourcePlate1	A	1	TargetPlate1	A	1
SourcePlate1	A	1	TargetPlate1	A	2
SourcePlate1	A	1	TargetPlate1	A	3
SourcePlate1	A	1	TargetPlate1	A	4

Step 4: Loading onto PIXL

Now the file is finished and exported as either a CSV or TSV file, save that to a USB stick and upload this onto PIXL. Run the Re-array program and select your file - PIXL will quickly scan the file to make sure there are no errors, it will either show a green tick or a red cross and explain where the errors are. Depending on the file type you've used, you may need to alter the settings, click on 'Edit' and 'File', make sure the drop down boxes are correct for your file delimiter, terminator and decimal.

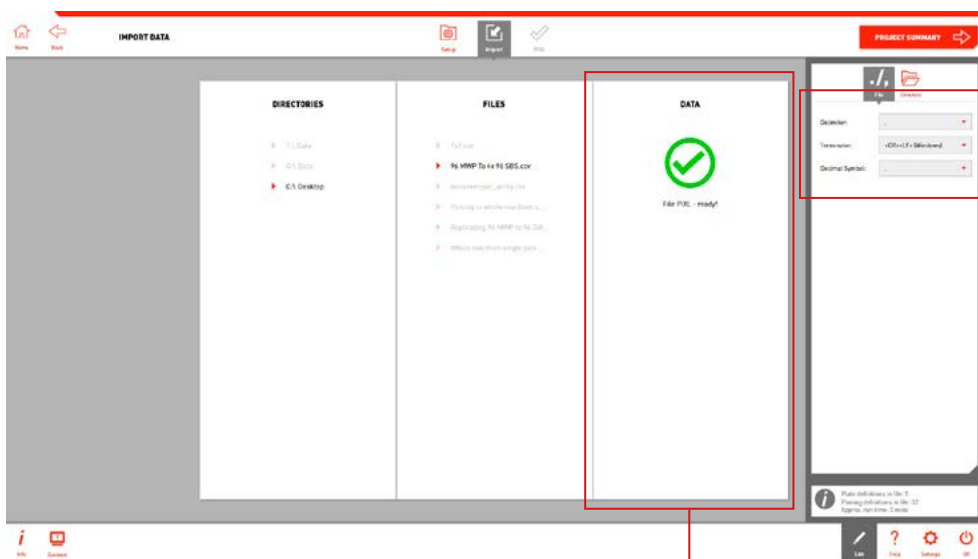

The Delimiter, Terminator and Decimal can be adjusted here.

Any errors in the file will appear here.

Note: A Re-Array Template is exported for all random colony picking projects.

This can be found in the PIXL tracking directory:

C:\Users**(user name)**\AppData\Roaming\Singer Instrument Company Limited\PIXL\Tracking

Simply open the required project folder for the rearray template.

Put in the plates, and... done; PIXL Master 2.0!

Please contact us if you're having any issues or need help. For more examples of PIXL re-array files, check out our Technical Support site: <http://bit.ly/pixlrearray>



SINGER INSTRUMENTS

A RESPONSIBILITY TO SCIENCE!

Roadwater
Watchet
Somerset
TA23 0RE
UK

+44 (0)1984 640226 (tel)
+44 (0)1984 641166 (fax)

contact@singerinstruments.com
singerinstruments.com



**SCAN TO VISIT WEBSITE FOR MORE
HELPFUL TIPS AND TUTORIALS!**



DISCLAIMER

At Singer Instruments, we are constantly seeking to improve our products and adapt them to the requirements of modern research techniques and testing methods. This involves modification to the mechanical structure and optical design of our instruments. Therefore, all descriptions and illustrations in this user guide, including all specifications are subject to change without notice.