

Membrane Air Dryer Series *IDG*

Dew point indicator confirms air drying at a glance

(except IDG1)
(optional on IDG3, IDG5, IDG3H, IDG5H)

- Compact
- Lightweight
- Space saving

Also available with fittings for purge air discharge

When purge air discharge is undesirable in the area around the membrane air dryer, it can be discharged to atmosphere via tubing (optional).

Discharged air noise reduced with built-in silencer

(Except IDG1, IDG3, IDG3H, IDG5, IDG5H, IDG30, IDG30H, IDG30L, IDG50, IDG50H, IDG50L)



Purge air discharge fitting for dew point indicator



Purge air discharge fitting for dehumidification



Environmentally friendly (non-freon)

Power supply not required

A power supply is completely unnecessary. Wiring labor is not required and there is no need to consider electrical standards, etc.

No vibration or heat discharge

There are no mechanical moving parts as in the case of refrigeration equipment.

Compatible with low dew points

Outlet air atmospheric pressure dew point -40°C
(IDG30L, IDG50L, IDG60L)
IDG75L, IDG100L

Outlet air atmospheric pressure dew point -60°C
(IDG60S, IDG75S, IDG100S)

Unit style Integrated pre-filter and regulator



IDG1

Flexible piping is possible

Low flow rate type tube configuration
Outlet air flow rate: 10l/min (ANR)



M type

Mist separator + Micro mist separator + IDG
Micro mist separator with pre-filter + IDG

V type

Mist separator + Micro mist separator + IDG + Regulator
Micro mist separator with pre-filter + IDG + Regulator

HA

IDG

AMG

AFF

AM

FQ1

Related products

Dehumidification principle

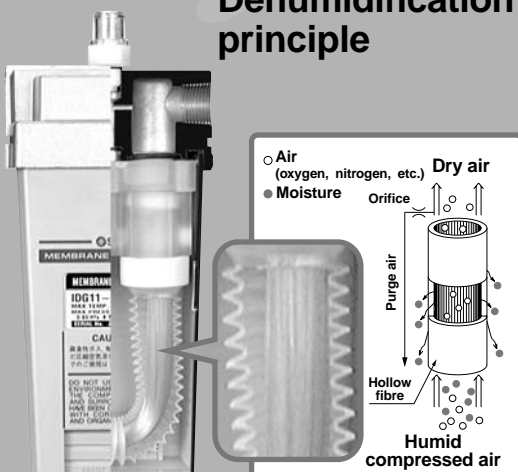

The membrane air dryer uses hollow fibres composed of a macro molecular membrane through which moisture passes easily, but is difficult for air (oxygen and nitrogen) to pass through.

When humid, compressed air is supplied to the inside of the hollow fibres, only moisture permeates the membrane and moves to the outside due to the pressure difference between the moisture inside and outside of the fibres. The compressed air becomes dry air and continues out of the dryer. Part of the dry air from the outlet side is passed through a very small orifice to reduce the pressure and purge the outside of the hollow fibres. The moisture which permeated to the outside of the hollow fibres is discharged to the atmosphere by this purge air. In this way, the partial pressure outside of the hollow fibres remains low and dehumidification is continuously performed.

Applications

- Machine tools (air bearings, lasers, etc.)
- Precision measuring equipment (3-D measuring machines)
- Semiconductor manufacturing equipment
Semiconductor inspection equipment
- Dental equipment
- Chemical analysis equipment
- Ozonizers, Hydrogen gas generating equipment
- Packaging machines, Paper making machines, Food processing machines
- Printed circuit board IC mounting machines
- Fine particle drying, Transfer equipment
- Electrostatic and high grade coating
- Drying and cleaning of precision parts
- Condensation prevention in control panels
- General pneumatic equipment and pneumatic tools

Series Variations

Compatible with a wide range of flow rates (10 to 1000ℓ/min (ANR)) and dew point temperatures (atmospheric pressure dew point: -15°C to -60°C)

IDG3, IDG3H: Outlet air flow rate 25ℓ/min (ANR) and IDG60S, IDG75S, IDG100S: Standard dew point -60°C types introduced

Standard dew point: -20°C ^{Note)} Standard purge Note) Standard purge rate: 20%	Standard dew point: -15°C ^{Note)} Low purge Note) Standard purge rate: 10%	Standard dew point: -40°C ^{Note)} Low dew point Note) Standard purge rate: 25%	Standard dew point: -60°C ^{Note)} Low dew point Note) Standard purge rate: 35%
---	--	--	--

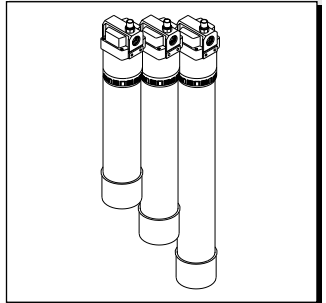
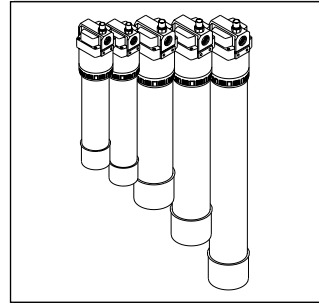
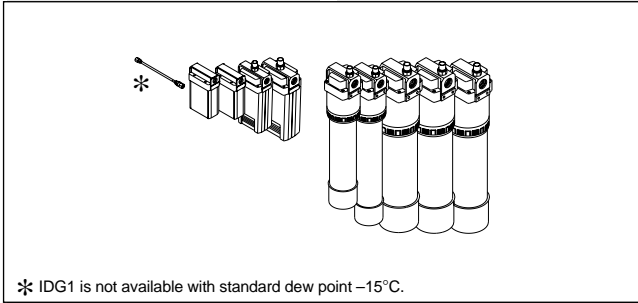

Single Style	Series	Outlet air flow rate ℓ/min (ANR) ^{Note)}	Series	Outlet air flow rate ℓ/min (ANR) ^{Note)}	Series	Outlet air flow rate ℓ/min (ANR) ^{Note)}	Series	Outlet air flow rate ℓ/min (ANR) ^{Note)}
	▼	IDG1	10	IDG3H	25	IDG30L	75	IDG60S
	IDG3	25	IDG5H	50	IDG50L	110	IDG75S	100
	IDG5	50	IDG10H	100	IDG60L	170	IDG100S	150
	IDG10	100	IDG20H	200	IDG75L	240		
	IDG20	200	IDG30H	300	IDG100L	300		
	IDG30	300	IDG50H	500				
	IDG50	500	IDG60H	600				
	IDG60	600	IDG75H	750				
	IDG75	750	IDG100H	1000				
	IDG100	1000						

Unit Style	M type A mist separator, micro mist separator, or micro mist separator with pre-filter combined with the single style							
	Series	Outlet air flow rate ℓ/min (ANR)	Series	Outlet air flow rate ℓ/min (ANR)	Series	Outlet air flow rate ℓ/min (ANR)	Series	Outlet air flow rate ℓ/min (ANR)
	IDG3M	25	IDG3HM	25	IDG30LM	75	IDG60SM	50
	IDG5M	50	IDG5HM	50	IDG50LM	110	IDG75SM	100
	IDG10M	100	IDG10HM	100	IDG60LM	170	IDG100SM	150
	IDG20M	200	IDG20HM	200	IDG75LM	240		
	IDG30M	300	IDG30HM	300	IDG100LM	300		
	IDG50M	500	IDG50HM	500				
	IDG60M	600	IDG60HM	600				
	IDG75M	750	IDG75HM	750				
	IDG100M	1000	IDG100HM	1000				

Unit Style	V type A regulator combined with the M type							
	Series	Outlet air flow rate ℓ/min (ANR)	Series	Outlet air flow rate ℓ/min (ANR)	Series	Outlet air flow rate ℓ/min (ANR)	Series	Outlet air flow rate ℓ/min (ANR)
	IDG3V	25	IDG3HV	25	IDG30LV	75	IDG60SV	50
	IDG5V	50	IDG5HV	50	IDG50LV	110	IDG75SV	100
	IDG10V	100	IDG10HV	100	IDG60LV	170	IDG100SV	150
	IDG20V	200	IDG20HV	200	IDG75LV	240		
	IDG30V	300	IDG30HV	300	IDG100LV	300		
	IDG50V	500	IDG50HV	500				
	IDG60V	600	IDG60HV	600				
	IDG75V	750	IDG75HV	750				
	IDG100V	1000	IDG100HV	1000				

Note) Standard dew point: Outlet air atmospheric pressure dew point under standard performance conditions
 Standard purge rate: Ratio of purge air flow rate to inlet air flow rate under standard performance conditions
 Outlet air flow rate: Value under standard performance conditions

Table of Contents

Single Style Standard Dew Point -20°C specifications P.4.2-3 Standard Dew Point -15°C specifications P.4.2-6 Standard Dew Point -40°C specifications P.4.2-10 Standard Dew Point -60°C specifications P.4.2-12	Unit Style P.4.2-18 Order Made P.4.2-34 Model Selection P.4.2-38 Flow Rate Characteristics P.4.2-40	Purge Air Flow Rate Charts ... P.4.2-42 Precautions P.4.2-43
---	---	---

Membrane Air Dryer Series **IDG**

Single Style/Standard Dew Point -20°C Specifications

How to Order

IDG 10 — **03**

• **Flow rate by size**

Size	Outlet air flow rate Purge air flow rate	ℓ/min (ANR)
1	10/2.5	
3	25/6	
5	50/12	
10	100/25	
20	200/50	
30	300/75	
50	500/125	
60	600/125	
75	750/150	
100	1000/190	

• **Optional specifications**

Symbol	Contents	Size									
		1	3	5	10	20	30	50	60	75	100
Nil	None (standard)	●	●	●	●	●	●	●	●	●	●
P	With fitting for purge air discharge	●	●	●	●	●	●	●	●	●	●
R	Flow direction (right→left)	—	●	●	●	●	●	●	●	●	●
S	With dew point indicator	—	●	●	—	—	—	—	—	—	—

Note) In case of two or more options, indicate them in alphabetical order.

• **Accessories**

Nil	None (standard)
B	With bracket (except IDG1)

Note) When symbol B is indicated, a bracket assembly with a part number shown in the table below is included as an accessory.

• **Port size**

Symbol	Bore	Size									
		1	3	5	10	20	30	50	60	75	100
01	1/8	—	●	●	—	—	—	—	—	—	—
02	1/4	●	●	●	●	●	●	—	—	—	—
03	3/8	—	—	—	●	●	●	●	—	—	—
04	1/2	—	—	—	—	—	—	—	●	●	●

• **Thread type**

Nil	Rc
N	NPT
F	G

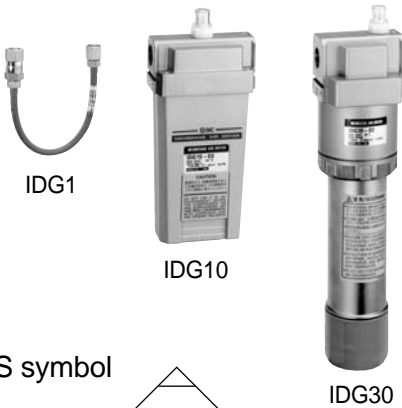

JIS symbol

• **Bracket assembly (accessory) part nos.**

Part no.	Applicable models
BM59	IDG3, 5
BM61	IDG10
BM63	IDG20
BM64	IDG30, 50
BM65	IDG60, 75, 100

* With cap bolts and spring washers

Standard Specifications/Single Style (Standard Dew Point -20°C)

Model		Standard dew point -20°C									
		IDG1	IDG3	IDG5	IDG10	IDG20	IDG30	IDG50	IDG60	IDG75	IDG100
Range of operating conditions	Fluid	Compressed air									
	Inlet air pressure MPa	0.3 to 0.85					0.3 to 1.0				
	Inlet air temperature $^{\circ}\text{C}$ (Note 1)	-5 to 55					-5 to 50				
	Ambient temperature $^{\circ}\text{C}$	-5 to 55					-5 to 50				
Standard performance	Outlet air atmospheric pressure dew point $^{\circ}\text{C}$	-20									
Standard performance conditions	Inlet air flow rate ℓ/min (ANR) (Note 2)	12.5	31	62	125	250	375	625	725	900	1190
	Outlet air flow rate ℓ/min (ANR)	10	25	50	100	200	300	500	600	750	1000
	Purge air flow rate ℓ/min (ANR) (Note 3)	2.5	6	12	25	50	75	125	125	150	190
	Inlet air pressure MPa	0.7									
	Inlet air temperature $^{\circ}\text{C}$	25									
	Inlet air saturation temperature $^{\circ}\text{C}$	25									
	Ambient temperature $^{\circ}\text{C}$	25									
Dew point indicator purge air flow rate	—					1ℓ/min (ANR) (inlet air pressure at 0.7MPa)					
Port size (nominal size B)	1/4	1/8, 1/4		1/4, 3/8			3/8, 1/2		1/2		
Weight kg (with bracket)	0.11	0.25 (0.31)	0.43 (0.51)	0.66 (0.76)	0.74 (0.87)	0.77 (0.90)	1.50 (1.65)	1.50 (1.65)	1.55 (1.70)		

Note 1) With no freezing.

Note 2) ANR indicates the flow rate converted to the value for 20°C at atmospheric pressure.

Note 3) Includes dew point indicator purge air flow rate of 1 ℓ/min (ANR) (inlet air pressure at 0.7MPa) (except IDG1, IDG3 and IDG5).

Series IDG

Conditions: Inlet air temperature 25°C (saturated air), Ambient temperature 25°C, P₁: Inlet air pressure, Tubing for purge air discharge (Option: P): None

Performance Charts

Note: Refer to page 4.2-5 when equipped with fitting for purge air discharge (Option: P).

IDG1

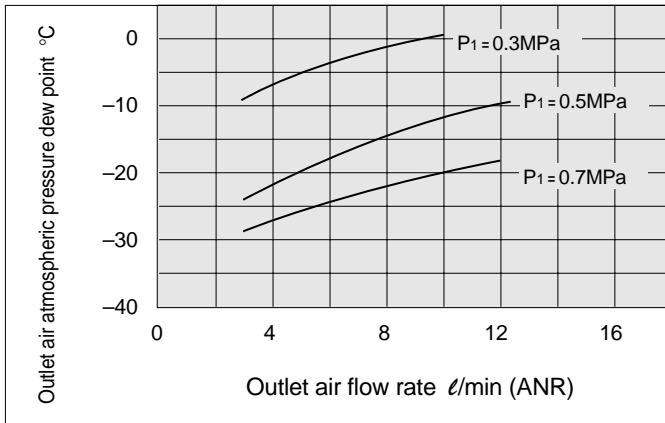

IDG3

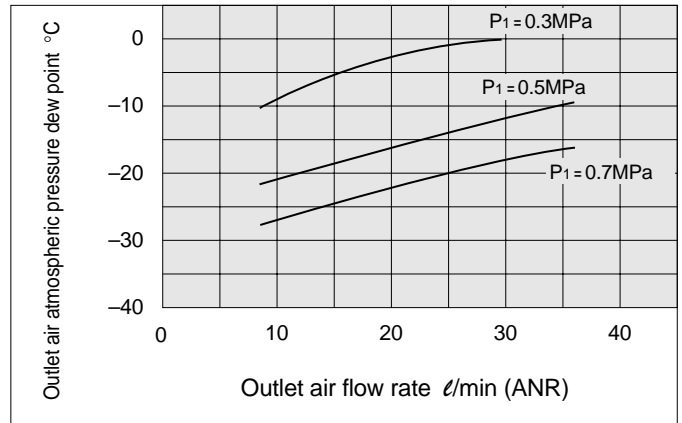

IDG5

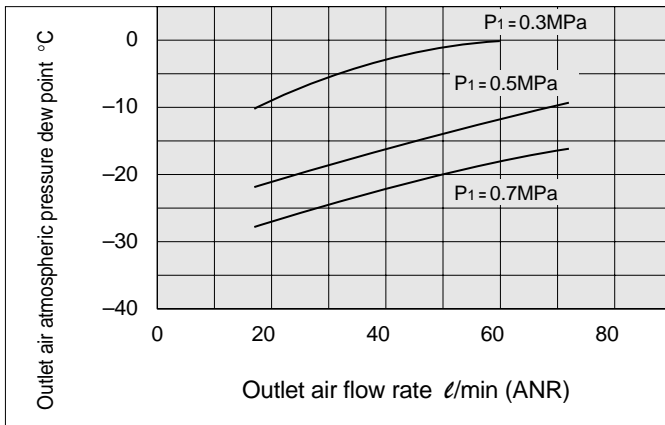

IDG10

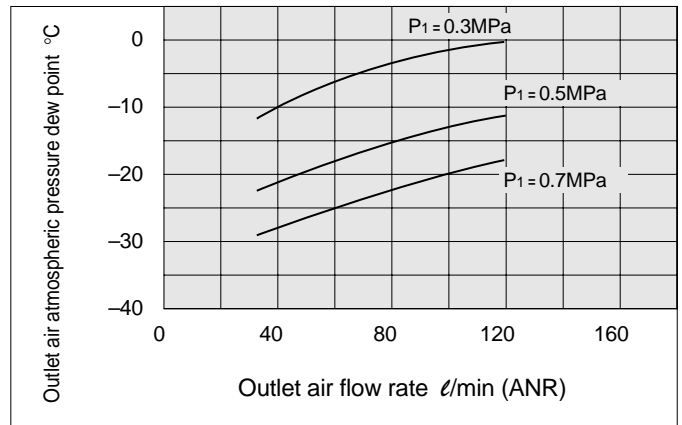

IDG20

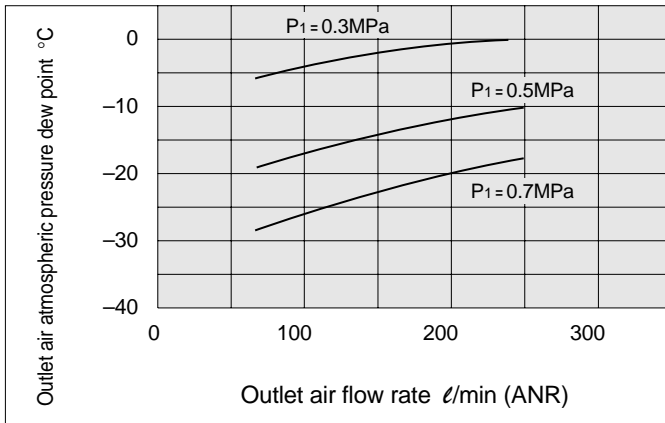

IDG30

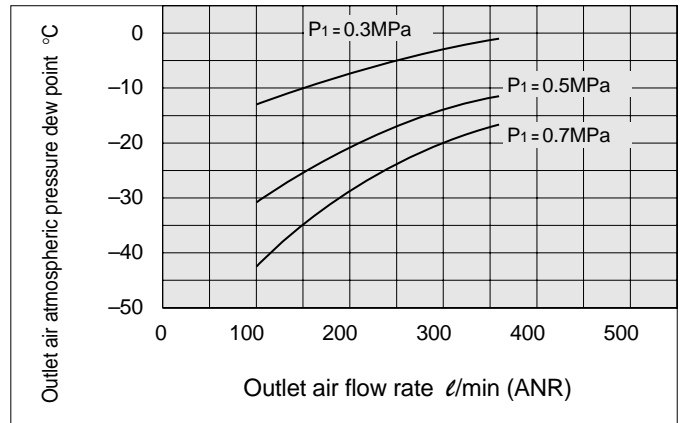

IDG50

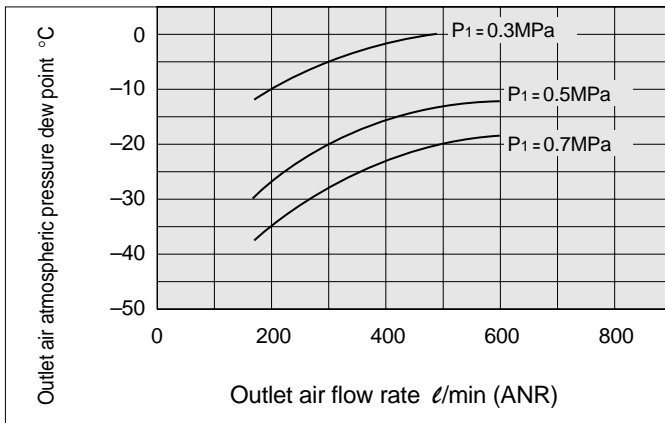

IDG60

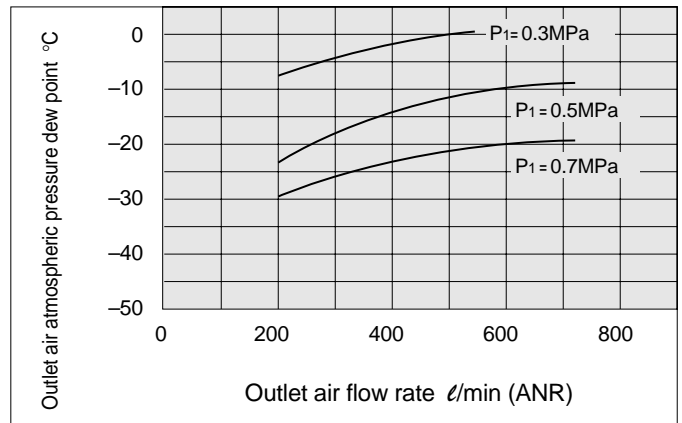

Performance Charts

Conditions: Inlet air temperature 25°C (saturated air), Ambient temperature 25°C, P₁: Inlet air pressure

IDG75

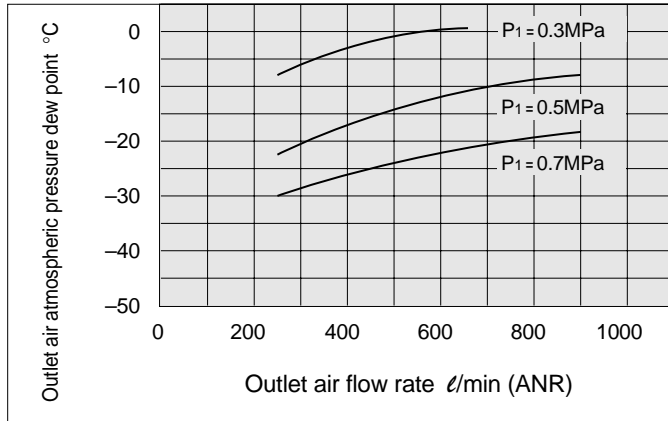

IDG100

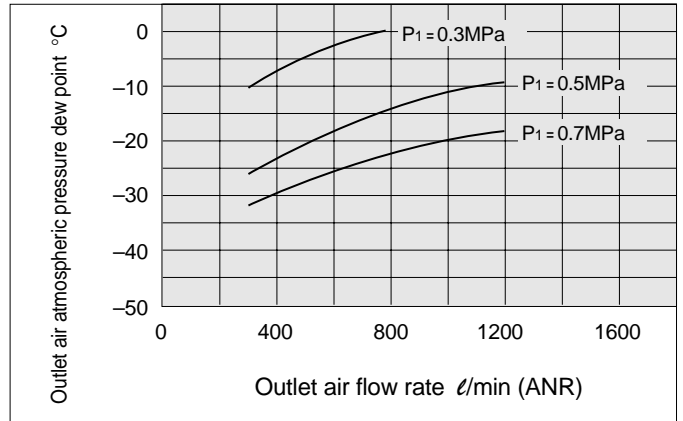

With fitting for purge air discharge (Option: P)

As the length of tubing for purge air discharge becomes longer, the outlet air atmospheric pressure dew point becomes higher. Refer to the table below.

Outlet air atmospheric pressure dew point by purge air discharge tube length °C

Tube length	Model	IDG30	IDG50
0m		-20	-20
1m		-19	-19
3m		-17	-17
5m		-16	-16

Note) In case of models other than the above, the outlet air atmospheric pressure dew point will increase by 1°C or less for tubing lengths of 5m or less.

■ Conditions

- Inlet air temperature: 25°C (saturated)
- Ambient temperature: 25°C
- Inlet air pressure: 0.7MPa
- Outlet air flow rate: Flow rate for standard performance conditions (Refer to page 1.)
- Tubing size (O.D. x I.D.) mm: ø12 x ø9

HA

IDG

AMG

AFF

AM

FQ1

Related products

Single Style/Standard Dew Point -15°C Specifications

How to Order

IDG 10 H — **03** —

• **Flow rate by size**

Size	Outlet air flow rate Purge air flow rate	ℓ/min (ANR)
3	25/3	
5	50/6	
10	100/11	
20	200/22	
30	300/35	
50	500/60	
60	600/65	
75	750/80	
100	1000/110	

• **Standard dew point temperature**

Symbol	Standard dew point $^{\circ}\text{C}$
H	-15

• **Thread type**

Nil	Rc
N	NPT
F	G

• **Optional specifications**

Symbol	Contents	Size									
		3	5	10	20	30	50	60	75	100	
Nil	None (standard)	●	●	●	●	●	●	●	●	●	
P	With fitting for purge air discharge	●	●	●	●	●	●	●	●	●	
R	Flow direction (right→left)	●	●	●	●	●	●	●	●	●	
S	With dew point indicator	●	●	Standard equipment							

Note) In case of two or more options, indicate them in alphabetical order.

• **Accessories**

Nil	None (standard)
B	With bracket

Note) When symbol B is indicated, a bracket assembly with a part number shown in the table below is included as an accessory.

• **Port size**

Symbol	Bore	Size								
		3	5	10	20	30	50	60	75	100
01	1/8	●	●	—	—	—	—	—	—	—
02	1/4	●	●	●	●	●	—	—	—	—
03	3/8	—	—	●	●	●	●	—	—	—
04	1/2	—	—	—	—	—	—	●	●	●



JIS symbol

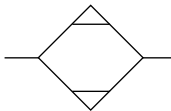

• **Bracket assembly (accessory) part nos.**

Part no.	Applicable models
BM59	IDG3H, 5H
BM61	IDG10H
BM63	IDG20H
BM64	IDG30H, 50H
BM65	IDG60H, 75H, 100H

* With cap bolts and spring washers

Standard Specifications/Single Style (Standard Dew Point -15°C)

Model		Standard dew point -15°C								
		IDG3H	IDG5H	IDG10H	IDG20H	IDG30H	IDG50H	IDG60H	IDG75H	IDG100H
Range of operating conditions	Fluid	Compressed air								
	Inlet air pressure MPa	0.3 to 0.85				0.3 to 1.0				
	Inlet air temperature $^{\circ}\text{C}$ <small>Note 1)</small>	-5 to 55				-5 to 50				
	Ambient temperature $^{\circ}\text{C}$	-5 to 55				-5 to 50				
Standard performance	Outlet air atmospheric pressure dew point $^{\circ}\text{C}$	-15								
	Inlet air flow rate ℓ/min (ANR) <small>Note 2)</small>	28	56	111	222	335	560	665	830	1110
Standard performance conditions	Outlet air flow rate ℓ/min (ANR)	25	50	100	200	300	500	600	750	1000
	Purge air flow rate ℓ/min (ANR) <small>Note 3)</small>	3	6	11	22	35	60	65	80	110
	Inlet air pressure MPa	0.7								
	Inlet air temperature $^{\circ}\text{C}$	25								
	Inlet air saturation temperature $^{\circ}\text{C}$	25								
Dew point indicator purge air flow rate	Ambient temperature $^{\circ}\text{C}$	25								
	Dew point indicator purge air flow rate	1 ℓ/min (ANR) (inlet air pressure at 0.7MPa)								
	Port size (nominal size B)	1/8, 1/4		1/4, 3/8			3/8, 1/2		1/2	
Weight kg (with bracket)	kg	0.25	0.43	0.66	0.74	0.77	1.50	1.50	1.55	
	(with bracket)	(0.31)	(0.51)	(0.76)	(0.87)	(0.90)	(1.65)	(1.65)	(1.70)	

Note 1) With no freezing.

Note 2) ANR indicates the flow rate converted to the value for 20°C at atmospheric pressure.

Note 3) Includes dew point indicator purge air flow rate of $1\ell/\text{min}$ (ANR) (inlet air pressure at 0.7MPa) (except IDG3H and IDG5H).

Membrane Air Dryer Series IDG

Conditions: Inlet air temperature 25°C (saturated air), Ambient temperature 25°C, P₁: Inlet air pressure, Purge air discharge tube (Option: P): None

Note: When equipped with fitting for purge air discharge (Option: P), the outlet air atmospheric pressure dew point will rise by 1°C or less for tubing lengths of 5m or less.

Performance Charts

IDG3H

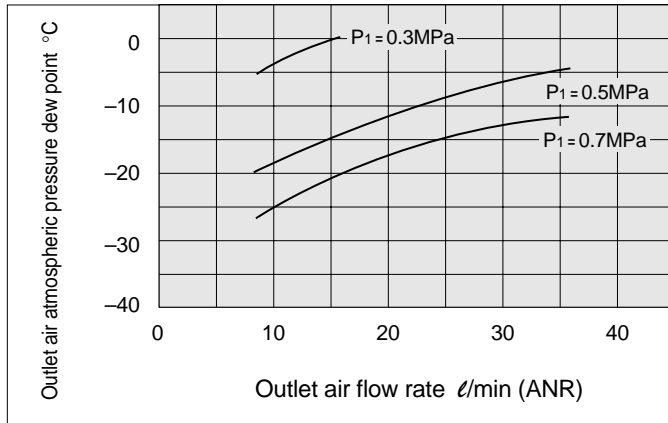

IDG5H

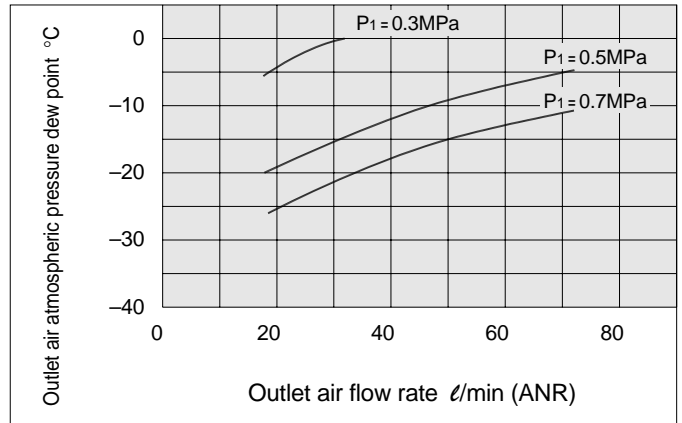

IDG10H

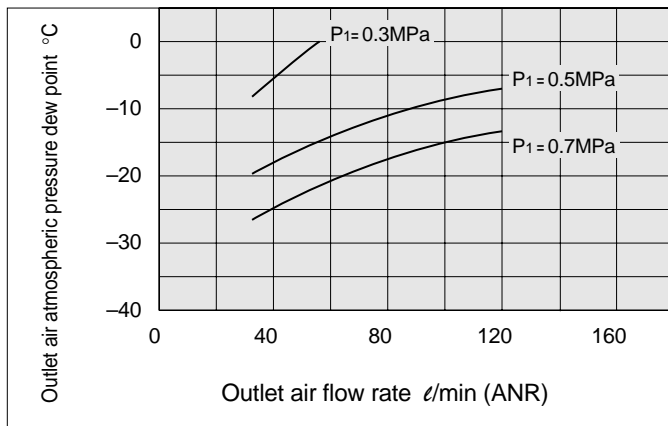

IDG20H

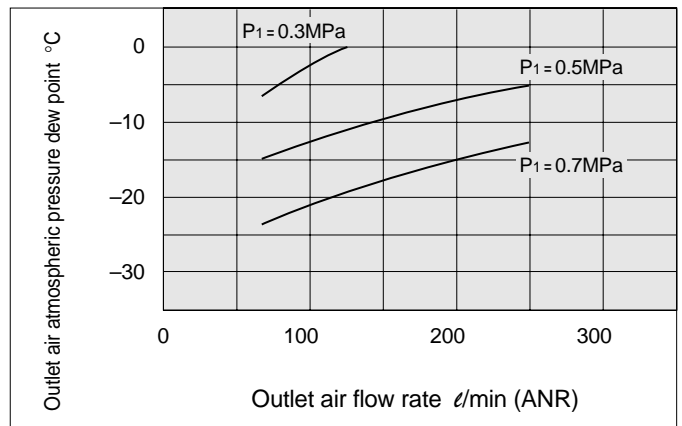

IDG30H

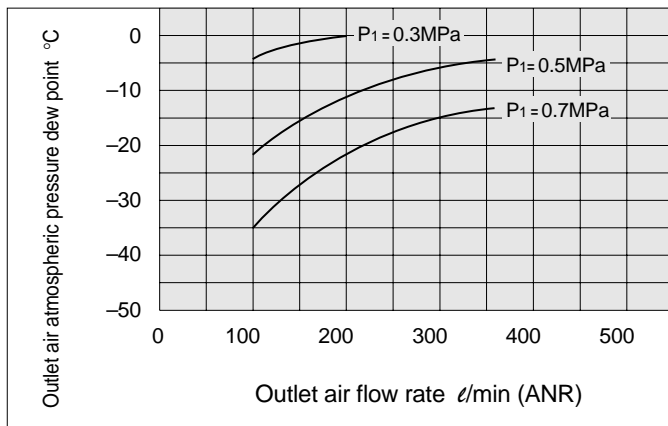

IDG50H

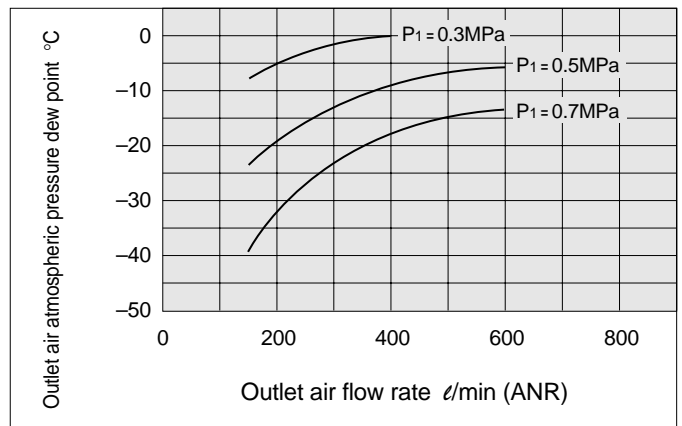

IDG60H

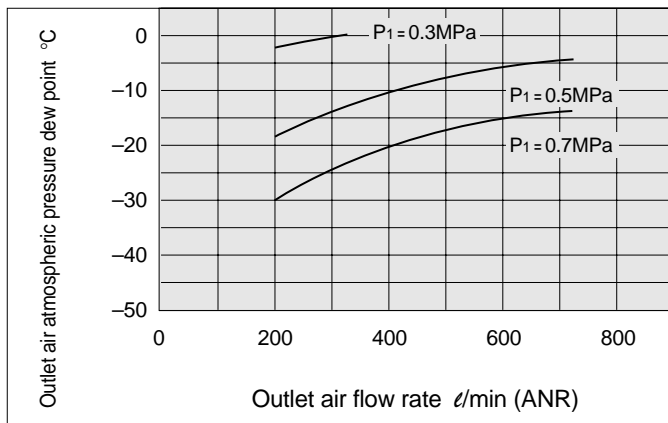

IDG75H

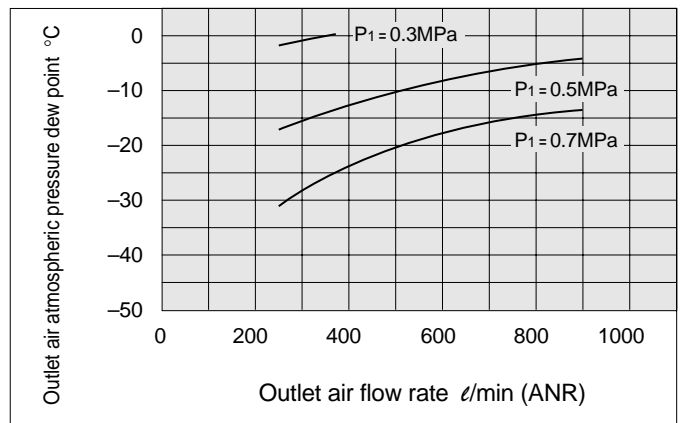

HA

IDG

AMG

AFF

AM

FQ1

Related products

Series IDG

Conditions: Inlet air temperature 25°C (saturated air), Ambient temperature 25°C, P₁: Inlet air pressure, Purge air discharge tube (Option: P): None

Performance Charts

Note: When equipped with fitting for purge air discharge (Option: P), the outlet air atmospheric pressure dew point will rise by 1°C or less for tubing lengths of 5m or less.

IDG100H

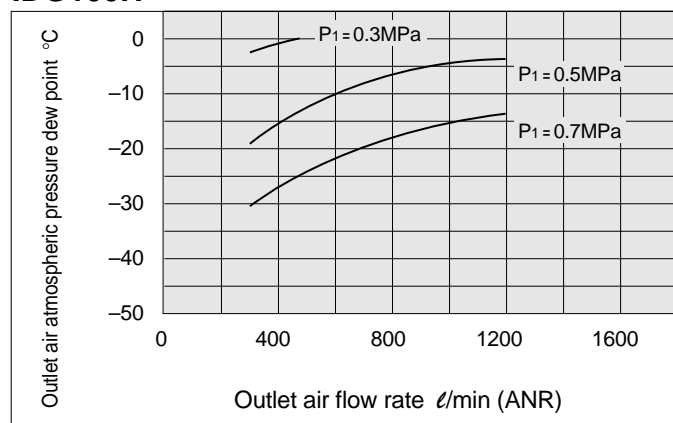

HA□

IDG

AMG

AFF

AM□

FQ1

Related
products

Single Style/Standard Dew Point –40°C Specifications

How to Order

IDG 50 L — 03 —

• **Flow rate by size**

Size	Outlet air flow rate Purge air flow rate ℓ/min (ANR)
30	75/25
50	110/40
60	170/57
75	240/80
100	300/100

• **Standard dew point temperature**

Symbol	Standard dew point °C
L	–40

• **Thread type**

Nil	Rc
N	NPT
F	G

• **Optional specifications**

Nil	None (standard)
P	With purge air discharge fitting
R	Flow direction (right→left)

Note) In case of two or more options, indicate them in alphabetical order.

• **Accessories**

Nil	None (standard)
B	With bracket

Note) When symbol B is indicated, a bracket assembly with a part number shown in the table below is included as an accessory.

• **Port size**

Symbol	Bore	Size				
		30	50	60	75	100
02	1/4	●	●	—	—	—
03	3/8	●	●	●	●	●
04	1/2	—	—	●	●	●



IDG30L



IDG60L

JIS symbol

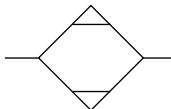

Bracket assembly (accessory) part nos.

Part no.	Applicable models
BM64	IDG30L, 50L
BM65	IDG60L, 75L, 100L

* With cap bolts and spring washers

Standard Specifications/Single Style (Standard Dew Point –40°C)

Model		Standard dew point –40°C				
		IDG30L	IDG50L	IDG60L	IDG75L	IDG100L
Range of operating conditions	Fluid	Compressed air				
	Inlet air pressure MPa	0.3 to 1.0				
	Inlet air temperature °C (Note 1)	–5 to 50				
	Ambient temperature °C	–5 to 50				
Standard performance	Outlet air atmospheric pressure dew point °C	–40				
Standard performance conditions	Inlet air flow rate ℓ/min (ANR) (Note 2)	100	150	227	320	400
	Outlet air flow rate ℓ/min (ANR)	75	110	170	240	300
	Purge air flow rate ℓ/min (ANR) (Note 3)	25	40	57	80	100
	Inlet air pressure MPa	0.7				
	Inlet air temperature °C	25				
	Inlet air saturation temperature °C	25				
	Ambient temperature °C	25				
Dew point indicator purge air flow rate		1 ℓ/min (ANR) {inlet air pressure at 0.7MPa}				
Port size (nominal size B)		1/4, 3/8		3/8, 1/2		
Weight kg (with bracket)		0.74 (0.87)	0.77 (0.90)	1.50 (1.65)	1.65 (1.80)	1.80 (1.95)

Note 1) With no freezing.

Note 2) ANR indicates the flow rate converted to the value for 20°C at atmospheric pressure.

Note 3) Includes dew point indicator purge air flow rate of 1ℓ/min (ANR) (inlet air pressure at 0.7MPa).

Performance Charts

Conditions: Inlet air temperature 25°C (saturated air), Ambient temperature 25°C
 P₁: Inlet air pressure, Tube for purge air discharge (Option: P): None

IDG30L

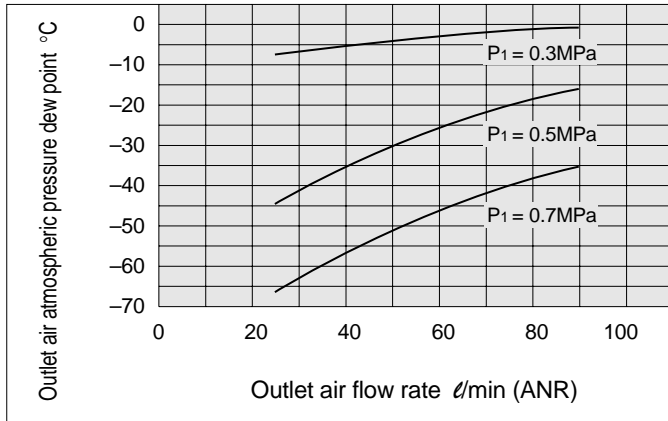

IDG50L

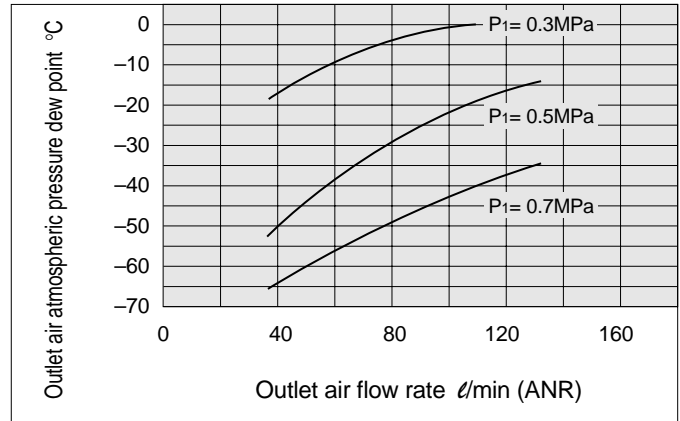

IDG60L

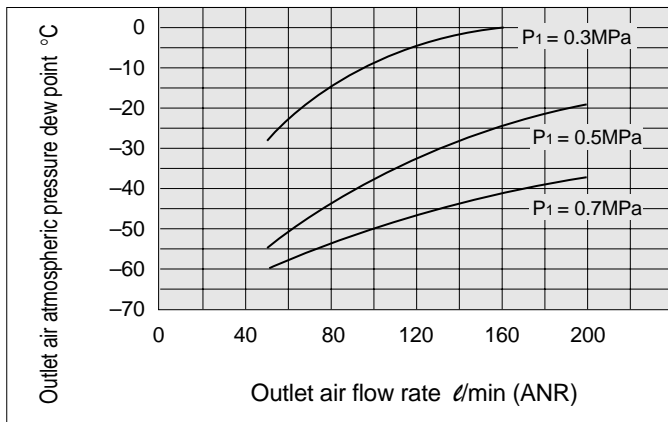

IDG75L

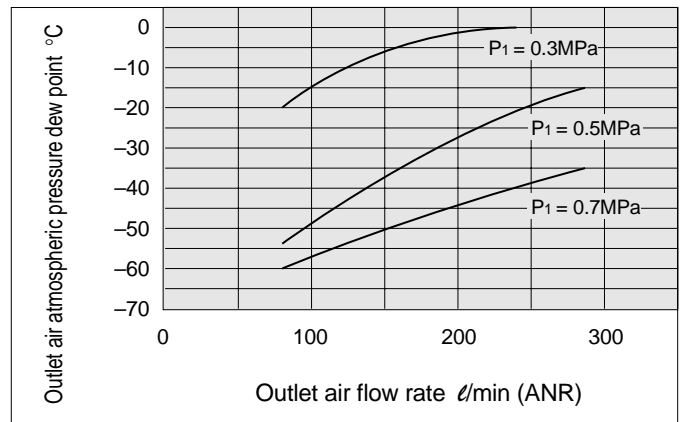

IDG100L

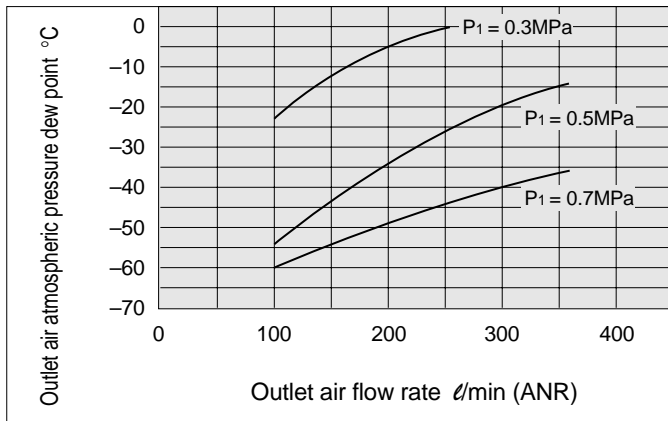

With fitting for purge air discharge (Option: P)

As the length of tubing for purge air discharge becomes longer, the outlet air atmospheric pressure dew point becomes higher. Refer to the table below.

Outlet air atmospheric pressure dew point by purge air discharge tube length °C

Tube length	Model	IDG30L	IDG50L
0m		-40	
1m		-39	
3m		-38	
5m			

Note) In case of models other than the above, the outlet air atmospheric pressure dew point will increase by 1°C or less for tubing lengths of 5m or less.

■ Conditions

- Inlet air temperature: 25°C (saturated)
- Ambient temperature: 25°C
- Inlet air pressure: 0.7MPa
- Outlet air flow rate: Flow rate for standard performance conditions (Refer to page 9.)
- Tubing size (O.D. x I.D.) mm: ø12 x ø9

HA

IDG

AMG

AFF

AM

FQ1

Related products

Single Style/Standard Dew Point -60°C Specifications

How to Order

IDG 60 S — 03 B

Flow rate by size

Size	Outlet air flow rate
	Purge air flow rate ℓ/min (ANR)
60	50/27
75	100/54
100	150/85

Standard dew point temperature

Symbol	Standard dew point °C
S	-60

Optional specifications

Nil	None (standard)
P	With purge air discharge fitting
R	Flow direction (right→left)

Note) In case of two or more options, indicate them in alphabetical order.

Accessories

Nil	None (standard)
B	With bracket

Note) When symbol B is indicated, a bracket assembly with a part number shown in the table below is included as an accessory.

Thread type

Nil	Rc
N	NPT
F	G

Port size

Symbol	Bore	Size		
		60	75	100
03	3/8	●	●	●
04	1/2	●	●	●



IDG60S

JIS symbol

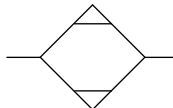

Bracket assembly (accessory) part nos.

Part no.	Applicable models
BM65	IDG60S, 75S, 100S

* With cap bolts and spring washers

Standard Specifications/Single Style (Standard Dew Point -60°C)

Model		Standard dew point -60°C		
		IDG60S	IDG75S	IDG100S
Range of operating conditions	Fluid	Compressed air		
	Inlet air pressure MPa	0.3 to 1.0		
	Inlet air temperature °C <small>Note 1)</small>	-5 to 50		
	Ambient temperature °C	-5 to 50		
Standard performance	Outlet air atmospheric pressure dew point °C	-60		
Standard performance conditions	Inlet air flow rate ℓ/min (ANR) <small>Note 2)</small>	77	154	235
	Outlet air flow rate ℓ/min (ANR)	50	100	150
	Purge air flow rate ℓ/min (ANR) <small>Note 3)</small>	27	54	85
	Inlet air pressure MPa	0.7		
	Inlet air temperature °C	25		
	Inlet air saturation temperature °C	25		
	Ambient temperature °C	25		
Dew point indicator purge air flow rate		1 ℓ/min (ANR) {inlet air pressure at 0.7MPa}		
Port size (nominal size B)		3/8, 1/2		
Weight kg (with bracket)		1.50 (1.65)	1.65 (1.80)	1.80 (1.95)

Note 1) With no freezing.

Note 2) ANR indicates the flow rate converted to the value for 20°C at atmospheric pressure.

Note 3) Includes dew point indicator purge air flow rate of 1ℓ/min (ANR) (inlet air pressure at 0.7MPa).

Membrane Air Dryer Series IDG

Conditions: Inlet air temperature 25°C (saturated air), Ambient temperature 25°C, P₁: Inlet air pressure, Purge air discharge tube (Option: P): None

Note: When equipped with fitting for purge air discharge (Option: P), the outlet air atmospheric pressure dew point will rise by 1°C or less for tubing lengths of 5m or less.

Performance Charts

IDG60S

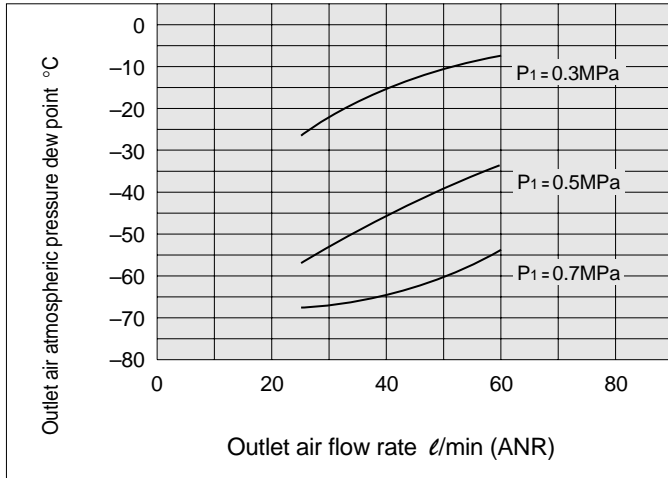

IDG75S

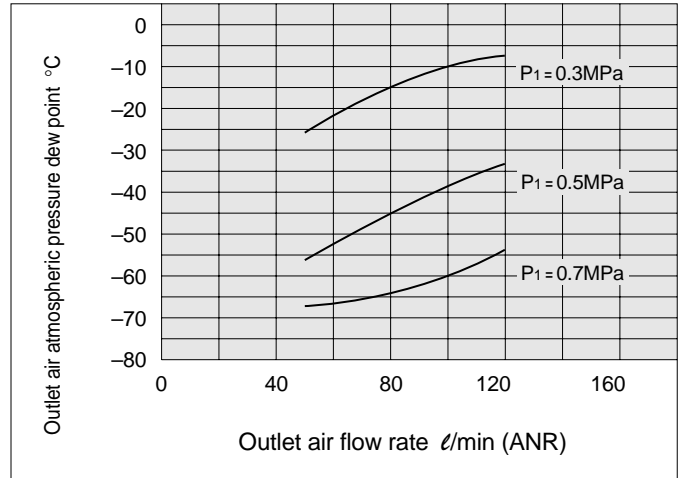

IDG100S

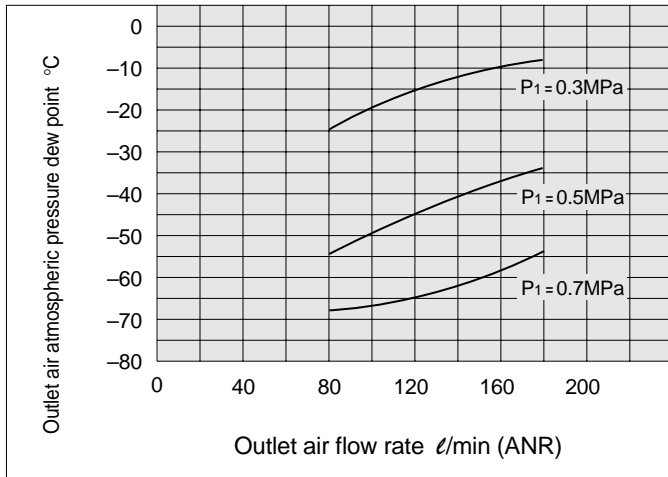

HA

IDG

AMG

AFF

AM

FQ1

Related products

Series IDG

Construction

IDG1

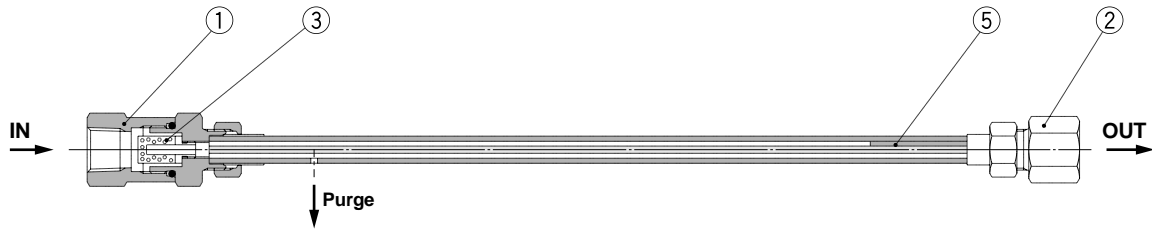

Optional specifications
With fitting for purge air discharge (Option: P)

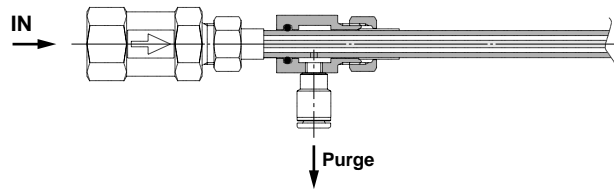

IDG3, 5 IDG3H, 5H

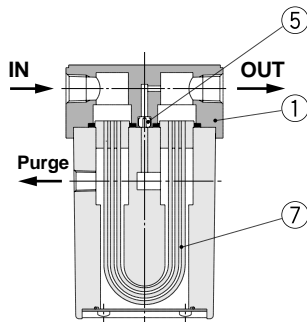

Optional specifications
With fitting for purge air discharge (Option: P)

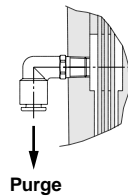

IDG10, 20 IDG10H, 20H

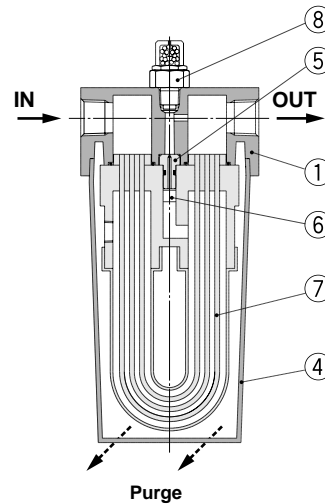

Optional specifications
With fitting for purge air discharge (Option: P)

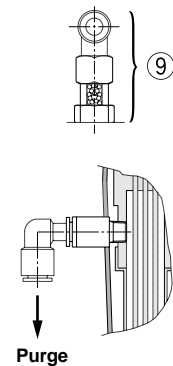

Parts list

No.	Description	Material					Note
		IDG1	IDG3, 3H	IDG5, 5H	IDG10, 10H	IDG20, 20H	
1	Body	Copper alloy	Aluminum alloy			Platinum silver coating (IDG1 is electroless nickel plated)	
2	Female connector	Copper alloy	—			Electroless nickel plated	
3	Strainer	Copper alloy	—				
4	Case	—	—	Resin			
5	Orifice	Resin	Stainless steel			IDG3H is resin	
6	Silencer	—	—	Copper alloy			

Replacement parts

No.	Description	Part number					Note
		IDG1	IDG3, 3H	IDG5, 5H	IDG10, 10H	IDG20, 20H	
7	Membrane module kit	—	IDG-EL3 IDG-EL3H	IDG-EL5 IDG-EL5H	IDG-EL10 IDG-EL10H	IDG-EL20 IDG-EL20H	
8	Dew point indicator kit	—			IDG-DP01		
9		—			IDG-DP01-X001		Option: P

**IDG30, 50,
IDG30H, 50H
IDG30L, 50L**

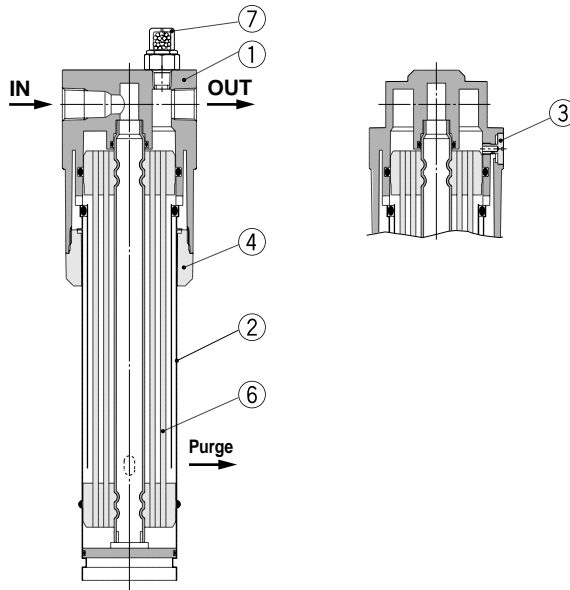

Optional specifications

With fitting for purge air discharge (Option: P)

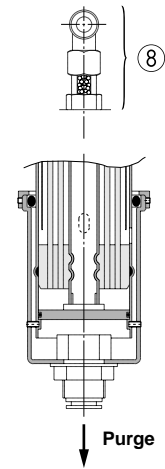

**IDG60, 75, 100
IDG60H, 75H, 100H
IDG60L, 75L, 100L
IDG60S, 75S, 100S**

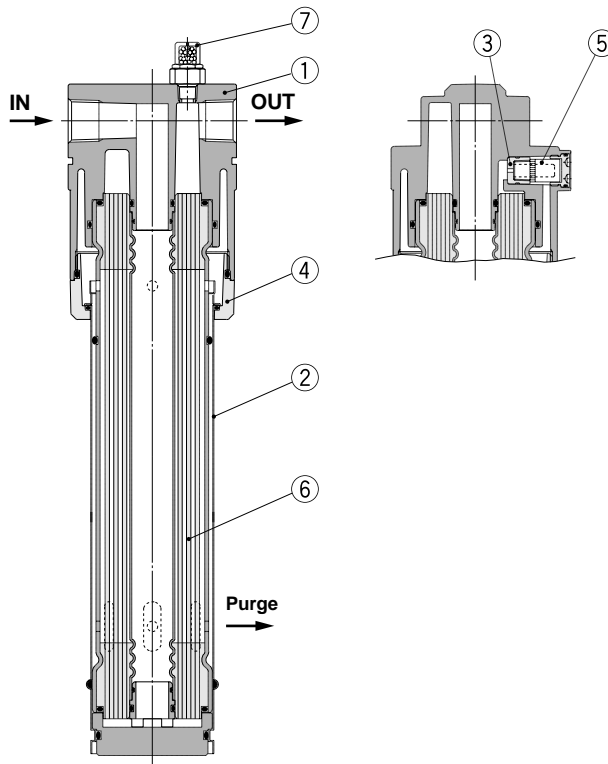

Optional specifications

With fitting for purge air discharge (Option: P)

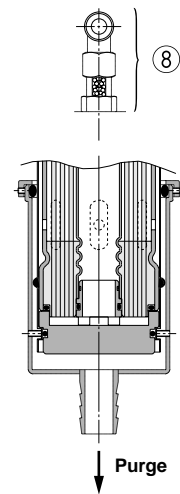

Parts list

No.	Description	Material					Note
		IDG30, 30H, 30L	IDG50, 50H, 50L	IDG60, 60H, 60L, 60S	IDG75, 75H, 75L, 75S	IDG100, 100H, 100L, 100S	
1	Body	Aluminum alloy					Platinum silver coating
2	Case	Stainless steel					
3	Orifice	Stainless steel					
4	Holder	Aluminum alloy		Aluminum			
5	Silencer	—		Resin + Copper alloy			

Replacement parts

No.	Description	Part number					Note
		IDG30, 30H, 30L	IDG50, 50H, 50L	IDG60, 60H, 60L, 60S	IDG75, 75H, 75L, 75S	IDG100, 100H, 100L, 100S	
6	Membrane module kit	IDG-EL30	IDG-EL50	IDG-EL60 IDG-EL60L	IDG-EL75 IDG-EL75L	IDG-EL100 IDG-EL100L	
7	Dew point indicator kit	IDG-DP01					
8		IDG-DP01-X001					Option: P

HA

IDG

AMG

AFF

AM

FQ1

Related products

Series IDG

Dimensions

IDG1

Purge air discharge tubing port for dehumidification

Applicable tube O.D.: $\phi 6$
(NPT thread: $\phi 1/4$ inch)

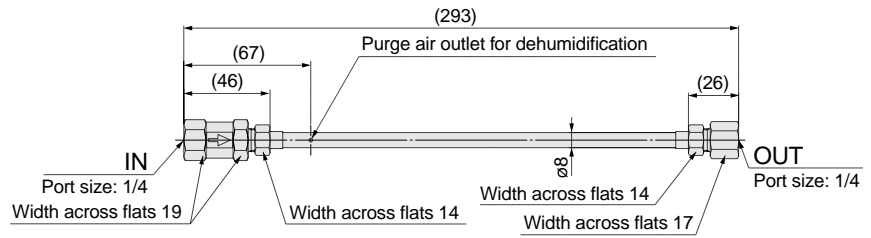
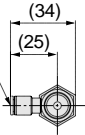

With fitting for purge air discharge (Option: P)

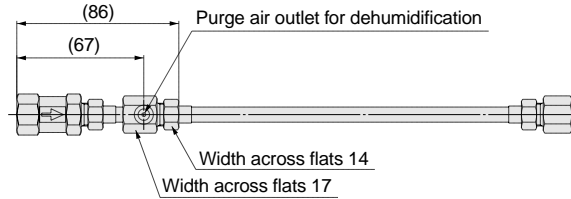

IDG3, 5 IDG3H, 5H

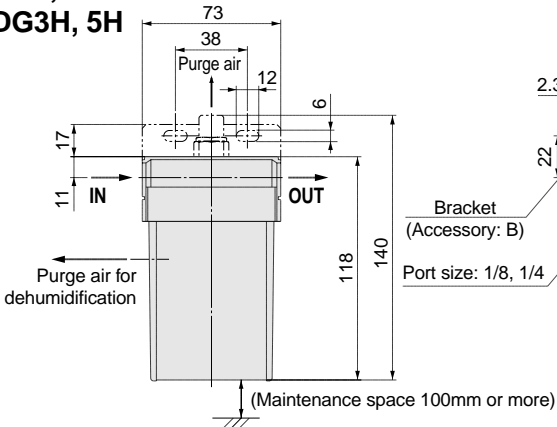

(Maintenance space 100mm or more)

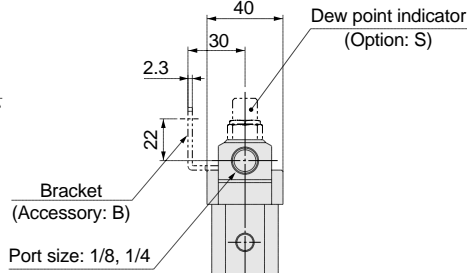

Bracket (Accessory: B)

Port size: 1/8, 1/4

With fitting for purge air discharge (Option: P)

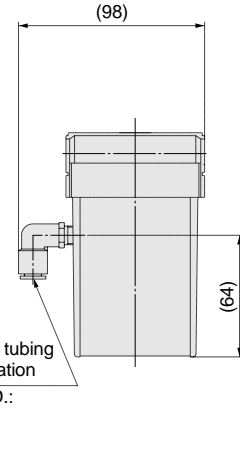

Purge air discharge tubing port for dehumidification
Applicable tube O.D.:
 $\phi 8$
 $\phi 5/16$ inch

IDG10, 20 IDG10H, 20H

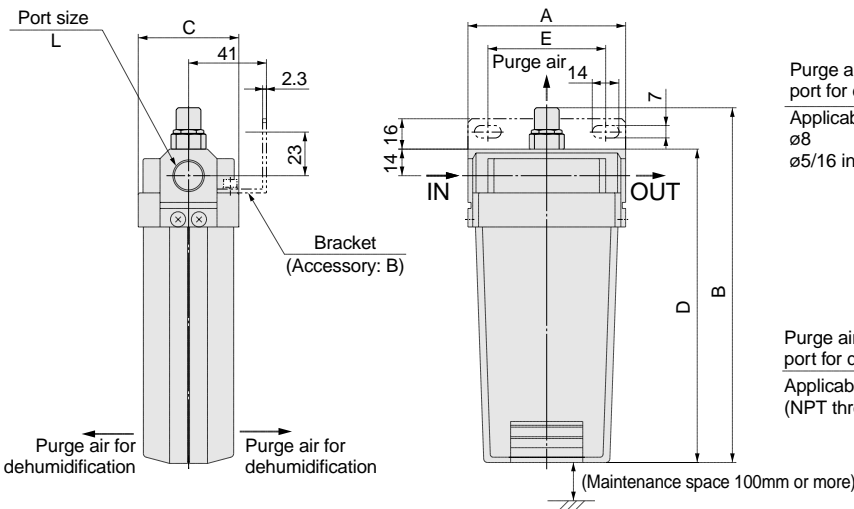

(Maintenance space 100mm or more)

With fittings for purge air discharge (Option: P)

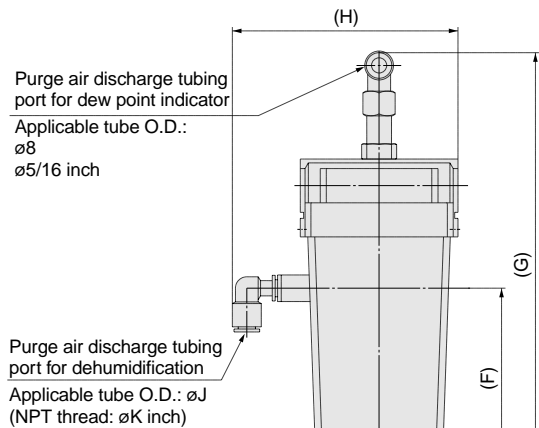

Purge air discharge tubing port for dew point indicator
Applicable tube O.D.:
 $\phi 8$
 $\phi 5/16$ inch

Purge air discharge tubing port for dehumidification
Applicable tube O.D.: ϕJ
(NPT thread: ϕK inch)

Model	Port size L	A	B	C	D	E	Option: P				
							F	G	H	J	K
IDG10, IDG10H	1/4, 3/8	83	187	53	165	62	97	224	119 [126]	8	5/16
IDG20, IDG20H		113	212	54	190	82	114	249	147 [154]	10	3/8

Values inside [] are for NPT threads

IDG30, 50 IDG30H, 50H IDG30L, 50L

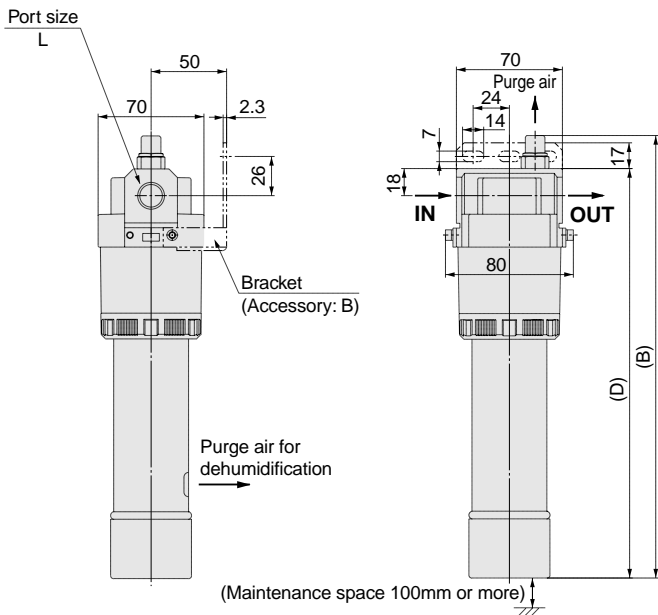

With fittings for purge air discharge (Option: P)

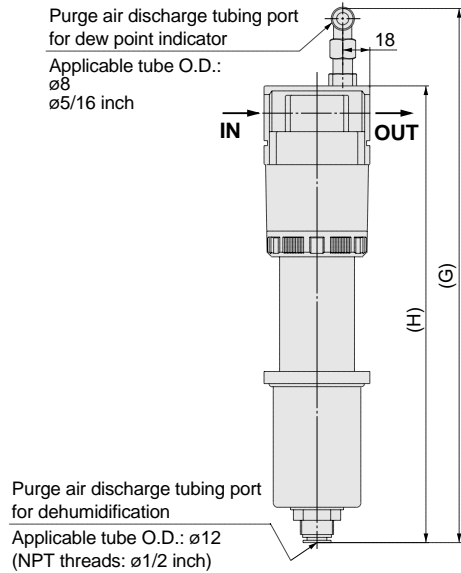

IDG60, 75, 100 IDG60H, 75H, 100H IDG60L, 75L, 100L IDG60S, 75S, 100S

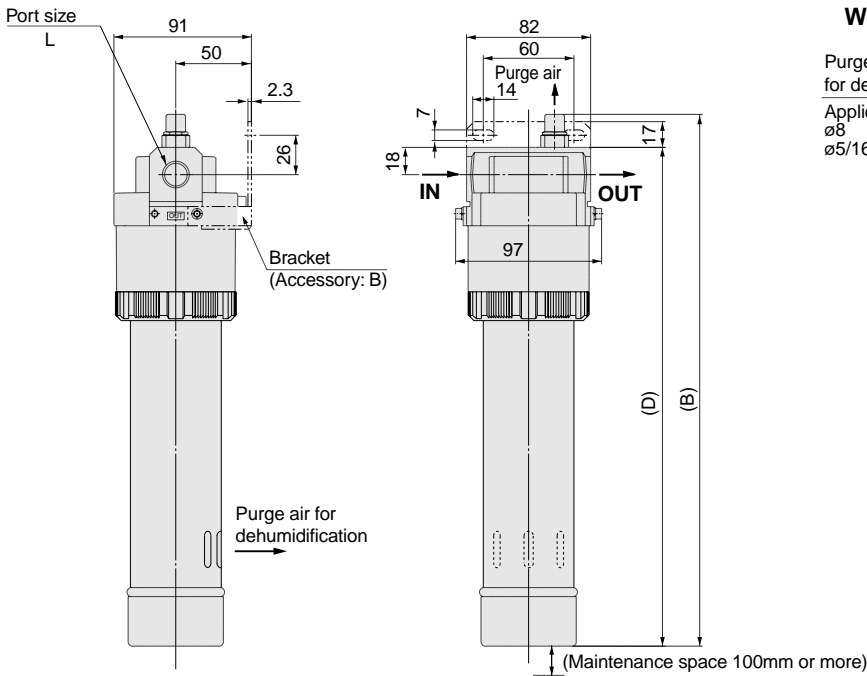

With fittings for purge air discharge (Option: P)

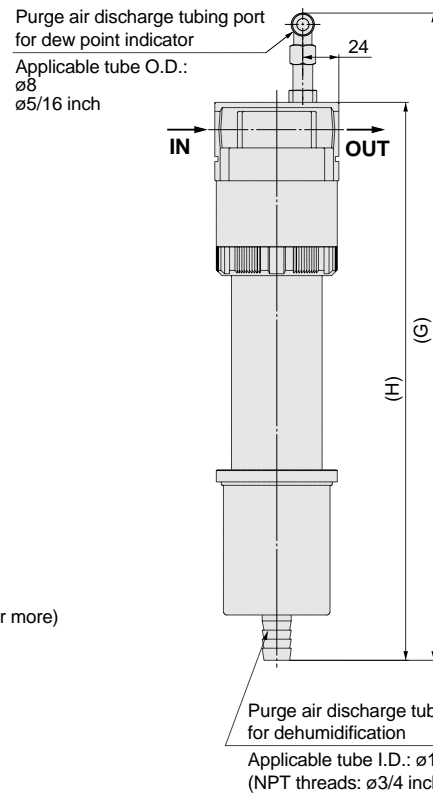

- HA
- IDG**
- AMG
- AFF
- AM
- FQ1
- Related products

Model	Port size L	B	D	Option: P	
				G	H
IDG30, 30H, 30L	1/4, 3/8	293	271	361	302
IDG50, 50H, 50L		337	315	405	346
IDG60, 60H	3/8, 1/2	352	330	428	369
IDG75, 75H, 100, 100H					
IDG60L, 60S	3/8, 1/2	392	370	468	409
IDG75L, 75S		472	450	548	489
IDG100L, 100S		542	520	618	559

Membrane Air Dryer Unit

Series *IDG*

Units (M Type, V Type)

How to Order



Size

3
5
10
20
30
50
60
75
100

Optional specifications*

Symbol	Contents	Size									
		3	5	10	20	30	50	60	75	100	
Nil	Standard	●	●	●	●	●	●	●	●	●	
P <small>Note 1)</small>	With fitting for purge air discharge	●	●	●	●	●	●	●	●	●	
R	Flow direction (right→left)	●	●	●	●	●	●	●	●	●	
S	With dew point indicator	●	●	Standard equipment							

* In case of two or more options, indicate them in an alphabetical order.
 Note 1) Symbol P is for M type only. This is not applicable to the V type since it is equipped with a relief type regulator,
 Note 2) This is not applicable in case of thread type symbols N and F, because barrel nipples are used for equipment connections.

Standard dew point temperature and air flow rate

Symbol	Standard dew point °C	Flow rate by size								Outlet air flow rate		
		3	5	10	20	30	50	60	75	100	Purge air flow rate	l/min (ANR)
Nil	-20	25/6	50/12	100/25	200/50	300/75	500/125	600/125	750/150	1000/190		
H	-15	25/3	50/6	100/11	200/22	300/35	500/60	600/65	750/80	1000/110		
L	-40	—	—	—	—	75/25	110/40	170/57	240/80	300/100		
S	-60	—	—	—	—	—	—	50/27	100/54	150/85		

Drain discharge method *

(Mist separator, Micro mist separator, Micro mist separator with pre-filter)

Symbol	Drain discharge method	Size and standard dew point				
		3, 3H 5, 5H	10, 10H 20, 20H	30, 30H, 30L 50, 50H, 50L	60, 60H 75, 75H	60L, 60S 75L, 75S 100L, 100S
Nil	Manual valve	●	●	●	●	●
C <small>Note 2)</small>	N.C. auto drain	—	●	●	—	●
D <small>Note 2)</small>	N.O. auto drain	● <small>Note 1)</small>	—	●	●	●
J	Drain guide (bore 1/4 without valve)	—	●	●	●	●

* Refer to "Specific Product Precautions/Selection" on page 46 regarding auto drain selection.

Note 1) Body sizes 3 and 5 have a differential pressure type auto drain.

Note 2) When symbols C or D are specified, an auto drain with a part number shown on page 4.2-20 is mounted.

Component equipment

Symbol	Contents	Description Model	Mist separator	Micro mist separator	Micro mist separator with pre-filter <small>Note 1)</small>	Membrane air dryer <small>Note 2)</small>	Regulator
IDG3H to IDG50H	●	●	—	●	—		
IDG30L/ IDG50L	●	●	—	●	—		
IDG60 to IDG100	—	—	●	●	—		
IDG60H to IDG100H	—	—	●	●	—		
IDG60L to IDG100L	●	●	—	●	—		
V	With separator regulator	IDG60S to IDG100S	●	●	—	●	—
		IDG3 to IDG50	●	●	—	●	●
		IDG3H to IDG50H	●	●	—	●	●
		IDG30L/ IDG50L	●	●	—	●	●
		IDG60 to IDG100	—	—	●	●	●
		IDG60H to IDG100H	—	—	●	●	●
V	With separator regulator	IDG60L to IDG100L	●	●	—	●	●
		IDG60S to IDG100S	●	●	—	●	●

Note 1) Specifications with element service indicator are also available. See the order made section on page 4.2-34.

Note 2) Specifications with micro mist separator regulator are also available. See the order made section on page 4.2-36.

Port size

Symbol	Bore	Size									
		3	5	10	20	30	50	60	75	100	
01	1/8	●	●	—	—	—	—	—	—	—	
02	1/4	●	●	●	●	—	—	—	—	—	
03	3/8	—	—	●	●	●	●	●	● <small>Note)</small>	● <small>Note)</small>	
04	1/2	—	—	—	—	—	—	●	●	●	

Note) Not applicable in case of standard dew points -20°C (Nil) and -15°C (symbol H).

Thread type

Nil	Rc
N	NPT
F	G

Standard Specifications/Units (M Type, V Type) [Standard Dew Point -20°C]

Model		Standard dew point -20°C								
		IDG3M	IDG5M	IDG10M	IDG20M	IDG30M	IDG50M	IDG60M	IDG75M	IDG100M
		IDG3V	IDG5V	IDG10V	IDG20V	IDG30V	IDG50V	IDG60V	IDG75V	IDG100V
Component equipment	Mist separator	AFM2000			AFM3000		AFM4000			
	Micro mist separator	AFD2000			AFD3000		AFD4000			
	Micro mist separator with pre-filter	—						AMH350	AMH450	
	Regulator (V type only)	AR2001			AR2501			AR4001		
Range of operating conditions	Fluid	Compressed air								
	Inlet air pressure MPa	0.3 to 0.85				0.3 to 1.0				
	Inlet air temperature °C	-5 to 55 ^{Note 1)}				-5 to 50 ^{Note 1)}		5 to 50		
	Ambient temperature °C	-5 to 55				-5 to 50		5 to 50		
Standard performance	Outlet air atmospheric pressure dew point °C	-20								
	Inlet air flow rate ℓ/min (ANR) ^{Note 2)}	31	62	125	250	375	625	725	900	1190
Standard performance conditions	Outlet air flow rate ℓ/min (ANR)	25	50	100	200	300	500	600	750	1000
	Purge air flow rate ℓ/min (ANR) ^{Note 3)}	6	12	25	50	75	125	125	150	190
	Inlet air pressure MPa	0.7								
	Inlet air temperature °C	25								
	Inlet air saturation temperature °C	25								
	Ambient temperature °C	25								
	Dew point indicator purge air flow rate	1ℓ/min (ANR) {inlet air pressure at 0.7MPa}								
Regulator construction (V type only)		Relief type								
Port size (nominal size B)		1/8, 1/4		1/4, 3/8			3/8, 1/2		1/2	
Weight kg (with auto drain)	M type	0.83 (0.90)	1.21 (1.30)	1.44 (1.53)	2.23 (2.33)	2.26 (2.36)	2.55 (2.65)	3.10 (3.20)	3.15 (3.25)	
	V type	1.28 (1.35)	1.67 (1.76)	1.90 (1.99)	3.34 (3.45)	3.37 (3.48)	3.74 (3.84)	4.29 (4.39)	4.34 (4.44)	

Note 1) With no freezing.

Note 2) ANR indicates the flow rate converted to the value for 20°C at atmospheric pressure.

Note 3) Includes dew point indicator purge air flow rate 1ℓ/min (ANR) (inlet air pressure at 0.7MPa) (except IDG3M, IDG3V, IDG5M and IDG5V).

Note 4) Refer to "Best Pneumatics No. 4" page 1.5-16 for regulator flow rate characteristics and pressure characteristics.

Note 5) When very clean air is required, refer to page 4.2-43 "Precautions on Design", item 2.



IDG10V



IDG30V



IDG60M

JIS symbol

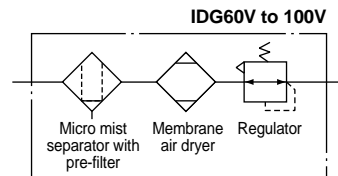
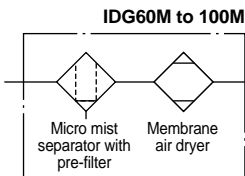
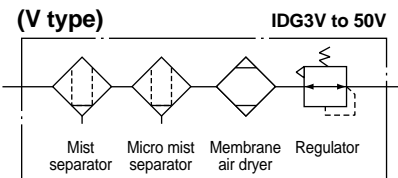
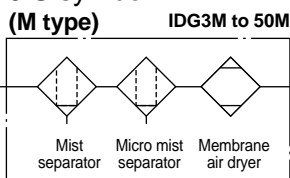

HA□

IDG

AMG

AFF

AM□

FQ1

Related products

Part numbers/Auto drain, Case assembly, Pressure gauge

Description	Applicable model	IDG3M	IDG5M	IDG10M	IDG20M	IDG30M	IDG50M	IDG60M	IDG75M	IDG100M
		IDG3V	IDG5V	IDG10V	IDG20V	IDG30V	IDG50V	IDG60V	IDG75V	IDG100V
Differential pressure type auto drain	AD62	—	—	—	—	—	—	—	—	—
Float type auto drain	N.C.	—	—	AD53		AD54		—	—	—
	N.O.	—	—	—	—	AD44		—	—	—
Case assembly (N.O.)	—	—	—	—	—	—	—	AMH-CA350-D	AMH-CA450-D	
Pressure gauge (V type only)	GC30-10									

Replacement parts (Mist separator, Micro mist separator, Element for micro mist separator with pre-filter)

Description	Model	AFM2000	AFD2000	AFM3000	AFD3000	AFM4000	AFD4000	AMH350	AMH450
Element assembly		630611	63092	630617	63093	630623	63094	AMH-EL350	AMH-EL450

Refer to pages 4.2-14 and 4.2-15 for membrane air dryer replacement parts.

Standard Specifications/Units (M Type, V Type) [Standard Dew Point -15°C]

Model		Standard dew point -15°C								
		IDG3HM	IDG5HM	IDG10HM	IDG20HM	IDG30HM	IDG50HM	IDG60HM	IDG75HM	IDG100HM
		IDG3HV	IDG5HV	IDG10HV	IDG20HV	IDG30HV	IDG50HV	IDG60HV	IDG75HV	IDG100HV
Component equipment	Mist separator	AFM2000		AFM3000		AFM4000		—		
	Micro mist separator	AFD2000		AFD3000		AFD4000		—		
	Micro mist separator with pre-filter	—		—		—		AMH350	AMH450	
	Regulator (V type only)	AR2001		AR2501		AR4001				
Range of operating conditions	Fluid	Compressed air								
	Inlet air pressure MPa	0.3 to 0.85				0.3 to 1.0				
	Inlet air temperature °C	-5 to 55 ^{Note 1)}				-5 to 50 ^{Note 1)}		5 to 50		
	Ambient temperature °C	-5 to 55				-5 to 50		5 to 50		
Standard performance	Outlet air atmospheric pressure dew point °C	-15								
Standard performance conditions	Inlet air flow rate ℓ/min (ANR) ^{Note 2)}	28	56	111	222	335	560	665	830	1110
	Outlet air flow rate ℓ/min (ANR)	25	50	100	200	300	500	600	750	1000
	Purge air flow rate ℓ/min (ANR) ^{Note 3)}	3	6	11	22	35	60	65	80	110
	Inlet air pressure MPa	0.7								
	Inlet air temperature °C	25								
	Inlet air saturation temperature °C	25								
	Ambient temperature °C	25								
Dew point indicator purge air flow rate		1ℓ/min (ANR) {inlet air pressure at 0.7MPa}								
Regulator construction (V type only)		Relief type								
Port size (nominal size B)		1/8, 1/4		1/4, 3/8			3/8, 1/2		1/2	
Weight kg (with auto drain)	M type	0.83 (0.90)	1.21 (1.30)	1.44 (1.53)	2.23 (2.33)	2.26 (2.36)	2.55 (2.65)	3.10 (3.20)	3.15 (3.25)	
	V type	1.28 (1.35)	1.67 (1.76)	1.90 (1.99)	3.34 (3.45)	3.37 (3.48)	3.74 (3.84)	4.29 (4.39)	4.34 (4.44)	

Note 1) With no freezing.

Note 2) ANR indicates the flow rate converted to the value for 20°C at atmospheric pressure.

Note 3) Includes dew point indicator purge air flow rate 1ℓ/min (ANR) (inlet air pressure at 0.7MPa) (except IDG5HM and 5HV).

Note 4) Refer to "Best Pneumatics No. 4" page 1.5-16 for regulator flow rate characteristics and pressure characteristics.

Note 5) When very clean air is required, refer to page 4.2-43 "Precautions on Design", item 2.



IDG10HV



IDG30HV



IDG60HM

JIS symbol

(M type) IDG3HM to 50HM

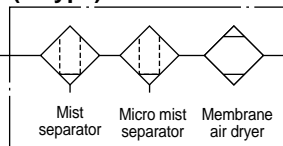

(V type) IDG3HV to 50HV

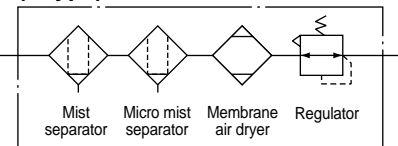

IDG60HM to 100HM

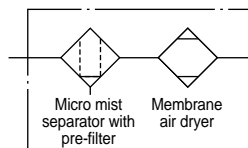

IDG60HV to 100HV

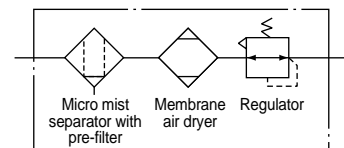

Part numbers/Auto drain, Case assembly, Pressure gauge

Description	Applicable model		IDG3HM	IDG5HM	IDG10HM	IDG20HM	IDG30HM	IDG50HM	IDG60HM	IDG75HM	IDG100HM
	IDG3HV	IDG5HV	IDG3HV	IDG5HV	IDG10HV	IDG20HV	IDG30HV	IDG50HV	IDG60HV	IDG75HV	IDG100HV
Differential pressure type auto drain	AD62		—	—	—	—	—	—	—	—	—
Float type auto drain	N.C.	—	—	AD53		AD54		—	—	—	—
	N.O.	—	—	—	—	AD44		—	—	—	—
Case assembly	—	—	—	—	—	—	—	—	AMH-CA350-D	AMH-CA450-D	
Pressure gauge (V type only)	GC30-10										

Replacement parts (Mist separator, Micro mist separator, Element for micro mist separator with pre-filter)

Description	Model	AFM2000	AFD2000	AFM3000	AFD3000	AFM4000	AFD4000	AMH350	AMH450
Element assembly		630611	63092	630617	63093	630623	63094	AMH-EL350	AMH-EL450

Refer to pages 4.2-14 and 4.2-15 for membrane air dryer replacement parts.

Standard Specifications/Units (M Type, V Type) [Standard Dew Point -40°C]

Model		Standard dew point -40°C				
		IDG30LM	IDG50LM	IDG60LM	IDG75LM	IDG100LM
		IDG30LV	IDG50LV	IDG60LV	IDG75LV	IDG100LV
Component equipment	Mist separator	AFM4000				
	Micro mist separator	AFD4000				
	Regulator (V type only)	AR4001				
Range of operating conditions	Fluid	Compressed air				
	Inlet air pressure MPa	0.3 to 1.0				
	Inlet air temperature °C <small>Note 1)</small>	-5 to 50				
	Ambient temperature °C	-5 to 50				
	Standard performance	Outlet air atmospheric pressure dew point °C	-40			
Standard performance conditions	Inlet air flow rate ℓ/min (ANR) <small>Note 2)</small>	100	150	227	320	400
	Outlet air flow rate ℓ/min (ANR)	75	110	170	240	300
	Purge air flow rate ℓ/min (ANR) <small>Note 3)</small>	25	40	57	80	100
	Inlet air pressure MPa	0.7				
	Inlet air temperature °C	25				
	Inlet air saturation temperature °C	25				
	Ambient temperature °C	25				
Dew point indicator purge air flow rate		1ℓ/min (ANR) {inlet air pressure at 0.7MPa}				
Regulator construction (V type only)		Relief type				
Port size (nominal size B)		1/4, 3/8			3/8, 1/2	
Weight kg (with auto drain)	M type	2.23 (2.33)	2.26 (2.36)	2.99 (3.09)	3.14 (3.24)	3.29 (3.39)
	V type	3.34 (3.45)	3.37 (3.48)	4.10 (4.20)	4.25 (4.35)	4.40 (4.50)

Note 1) With no freezing.

Note 2) ANR indicates the flow rate converted to the value for 20°C at atmospheric pressure.

Note 3) Includes dew point indicator purge air flow rate 1ℓ/min (ANR) (inlet air pressure at 0.7MPa).

Note 4) Refer to "Best Pneumatics No. 4" page 1.5-16 for regulator flow rate characteristics and pressure characteristics.

Note 5) When very clean air is required, refer to page 4.2-43 "Precautions on Design", item 2.



IDG30LV

JIS symbol
(M type)

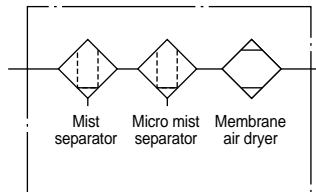

(V type)

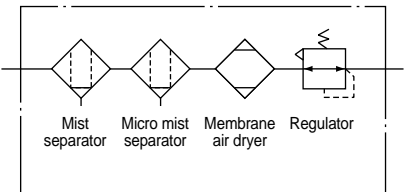

IDG60LV



IDG60LM

Part numbers/Auto drain, Pressure gauge

Description		Applicable model				
		IDG30LM IDG30LV	IDG50LM IDG50LV	IDG60LM IDG60LV	IDG75LM IDG75LV	IDG100LM IDG100LV
Float type auto drain	N.C.	AD54				
	N.O.	AD44				
Pressure gauge		GC30-10				

Replacement parts (Mist separator, Element for micro mist separator)

Description	Model	AFM4000	AFD4000
Element assembly		630623	63094

Refer to pages 4.2-14 and 4.2-15 for membrane air dryer replacement parts.

HA□

IDG

AMG

AFF

AM□

FQ1

Related products

Standard Specifications/Units (M Type, V Type) [Standard Dew Point -60°C]

Model		Standard dew point -60°C		
		IDG60SM IDG60SV	IDG75SM IDG75SV	IDG100SM IDG100SV
Component equipment	Mist separator	AFM4000		
	Micro mist separator	AFD4000		
	Regulator (V type only)	AR4001		
Range of operating conditions	Fluid	Compressed air		
	Inlet air pressure MPa	0.3 to 1.0		
	Inlet air temperature °C <small>Note 1)</small>	-5 to 50		
	Ambient temperature °C	-5 to 50		
Standard performance	Outlet air atmospheric pressure dew point °C	-60		
Standard performance conditions	Inlet air flow rate ℓ/min (ANR) <small>Note 2)</small>	77	154	235
	Outlet air flow rate ℓ/min (ANR)	50	100	150
	Purge air flow rate ℓ/min (ANR) <small>Note 3)</small>	27	54	85
	Inlet air pressure MPa	0.7		
	Inlet air temperature °C	25		
	Inlet air saturation temperature °C	25		
	Ambient temperature °C	25		
Dew point indicator purge air flow rate		1ℓ/min (ANR) {inlet air pressure at 0.7MPa}		
Regulator construction (V type only)		Relief type		
Port size (nominal size B)		3/8, 1/2		
Weight kg (with auto drain)	M type	2.99 (3.09)	3.14 (3.24)	3.29 (3.39)
	V type	4.10 (4.20)	4.25 (4.35)	4.40 (4.50)

Note 1) With no freezing.

Note 2) ANR indicates the flow rate converted to the value for 20°C at atmospheric pressure.

Note 3) Includes dew point indicator purge air flow rate 1ℓ/min (ANR) (inlet air pressure at 0.7MPa).

Note 4) Refer to "Best Pneumatics No. 4" page 1.5-16 for regulator flow rate characteristics and pressure characteristics.

Note 5) When very clean air is required, refer to page 4.2-43 "Precautions on Design", item 2.



IDG60SV



IDG60SM

JIS symbol (M type)

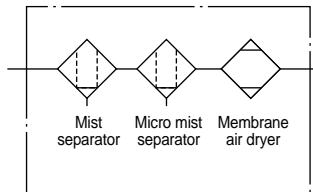

(V type)

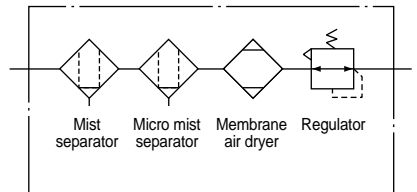

Part numbers/Auto drain, Pressure gauge

Description		Applicable model		
		IDG60SM IDG60SV	IDG75SM IDG75SV	IDG100SM IDG100SV
Float type auto drain	N.C.	AD54		
	N.O.	AD44		
Pressure gauge		GC30-10		

Replacement parts (Mist separator, Element for micro mist separator)

Description	Model	AFM4000	AFD4000
Element assembly		630623	63094

Refer to pages 4.2-14 and 4.2-15 for membrane air dryer replacement parts.

Flow Rate Characteristics

Conditions: Inlet air temperature 25°C, P₁: Inlet air pressure

IDG3M, 3V (standard dew point -20°C)
IDG3HM, 3HV (standard dew point -15°C)

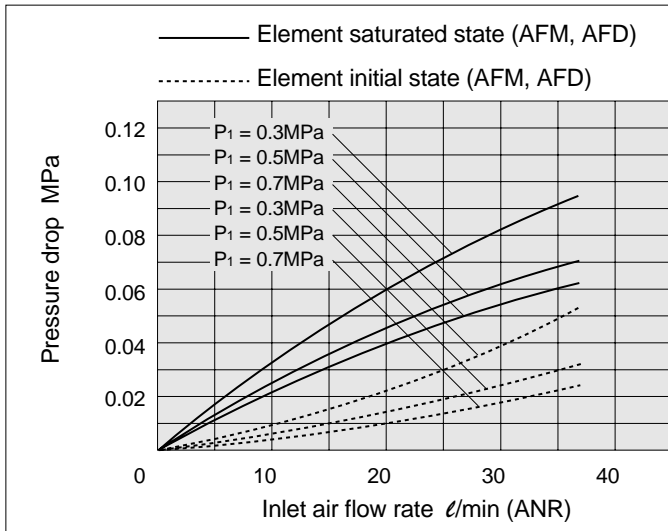

IDG5M, 5V (standard dew point -20°C)
IDG5HM, 5HV (standard dew point -15°C)

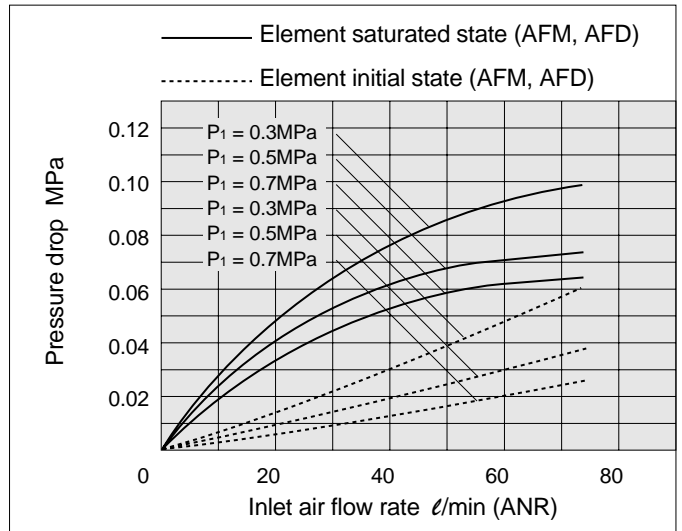

IDG10M, 10V (standard dew point -20°C)
IDG10HM, 10HV (standard dew point -15°C)

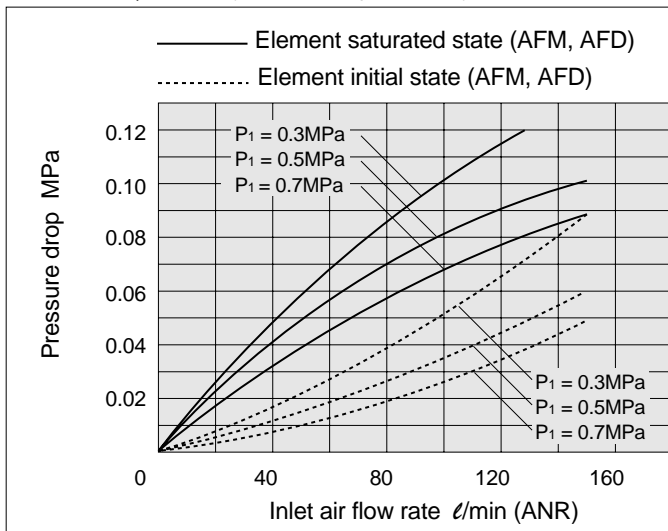

IDG20M, 20V (standard dew point -20°C)
IDG20HM, 20HV (standard dew point -15°C)

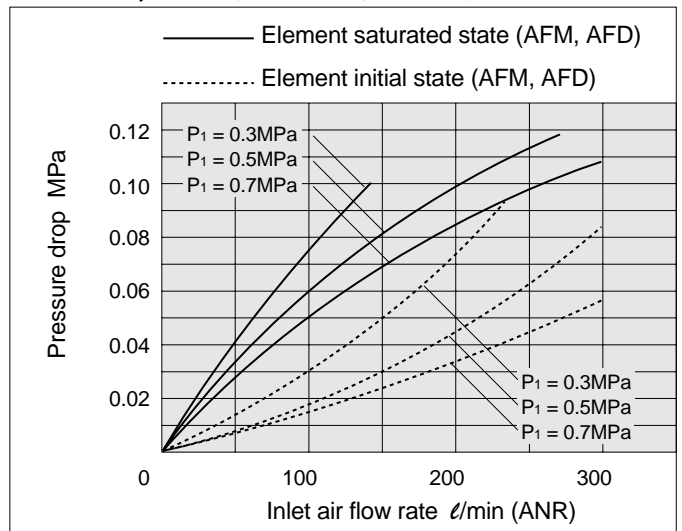

IDG30M, 30V (standard dew point -20°C)
IDG30HM, 30HV (standard dew point -15°C)
IDG30LM, 30LV (standard dew point -40°C)

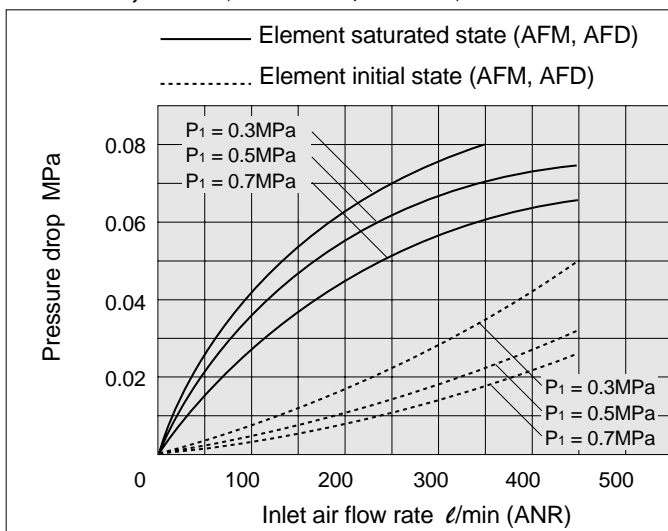

IDG50M, 50V (standard dew point -20°C)
IDG50HM, 50HV (standard dew point -15°C)
IDG50LM, 50LV (standard dew point -40°C)

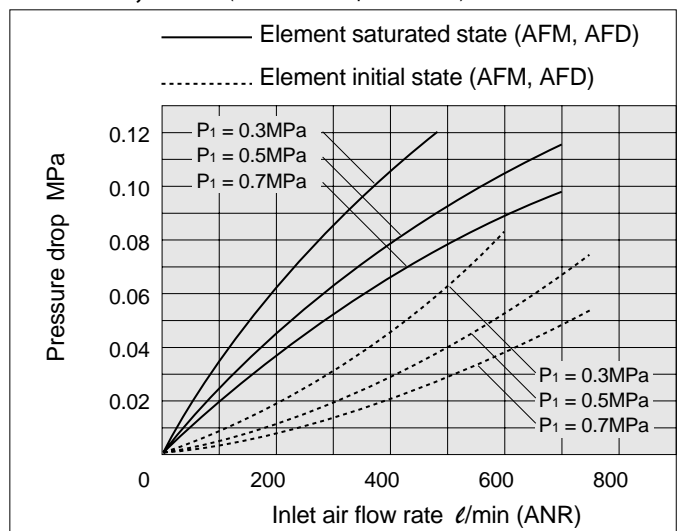

HA

IDG

AMG

AFF

AM

FQ1

Related products

Flow Rate Characteristics

Conditions: Inlet air temperature 25°C, P₁: Inlet air pressure

IDG60M, 60V (standard dew point -20°C)
IDG60HM, 60HV (standard dew point -15°C)

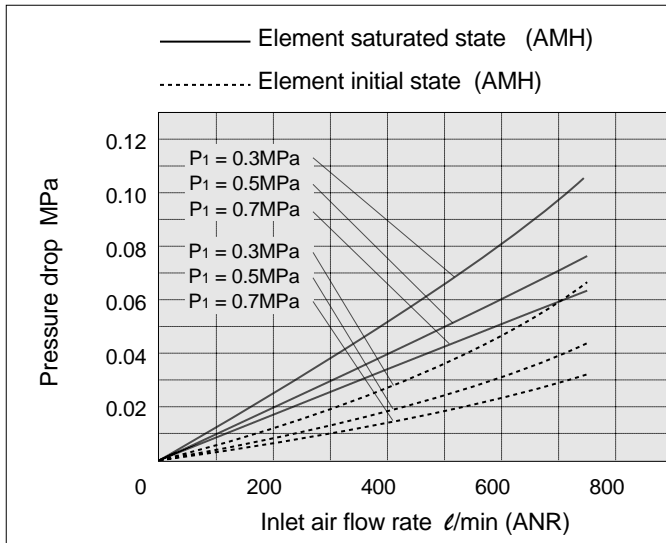

IDG60LM, 60LV (standard dew point -40°C)
IDG60SM, 60SV (standard dew point -60°C)

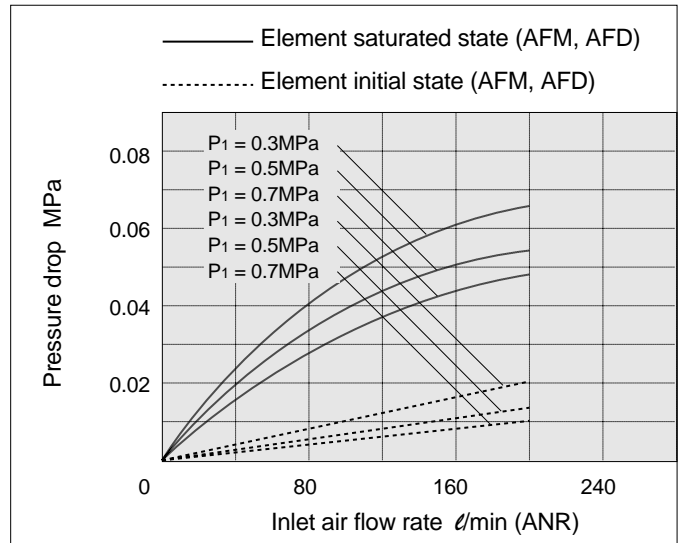

IDG75M, 75V (standard dew point -20°C)
IDG75HM, 75HV (standard dew point -15°C)

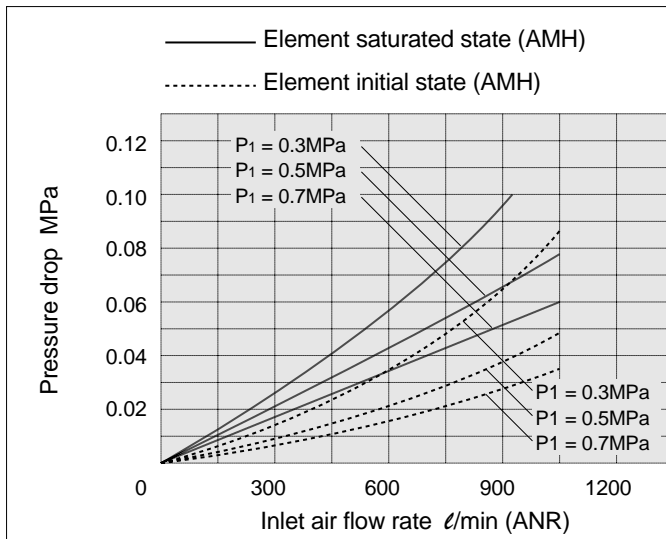

IDG75LM, 75LV (standard dew point -40°C)
IDG75SM, 75SV (standard dew point -60°C)

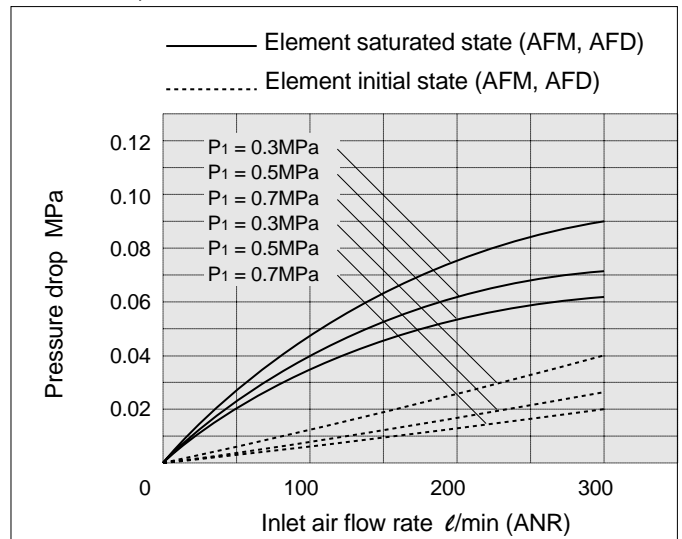

IDG100M, 100V (standard dew point -20°C)
IDG100HM, 100HV (standard dew point -15°C)

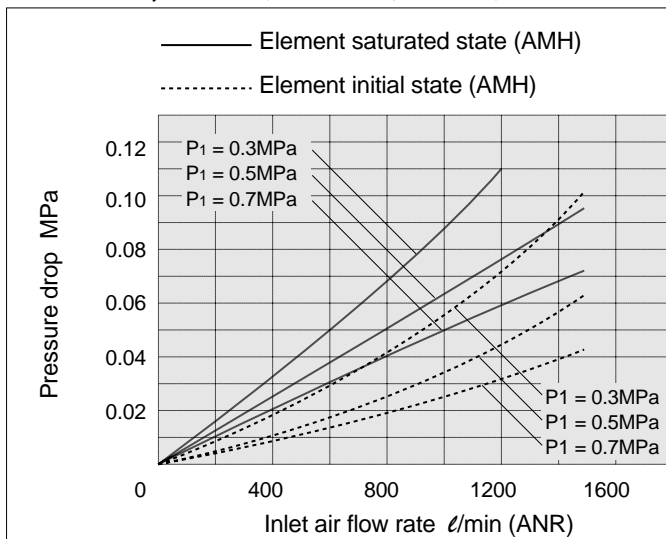

IDG100LM, 100LV (standard dew point -40°C)
IDG100SM, 100SV (standard dew point -60°C)

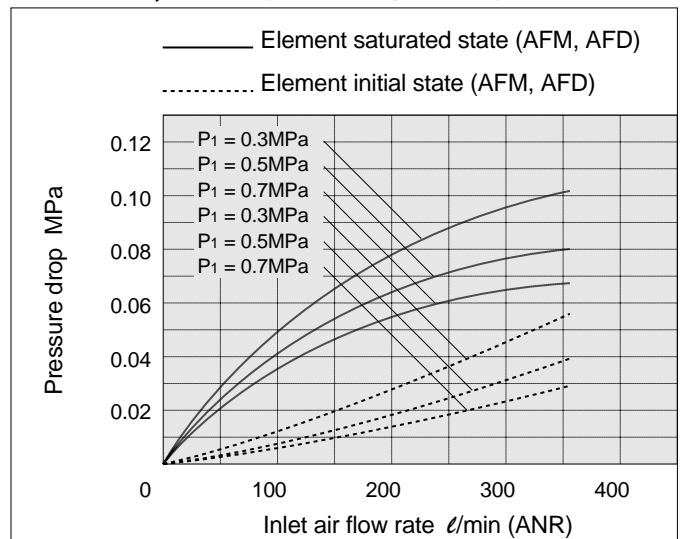

Dimensions (M Type)

IDG3M, 5M
IDG3HM, 5HM

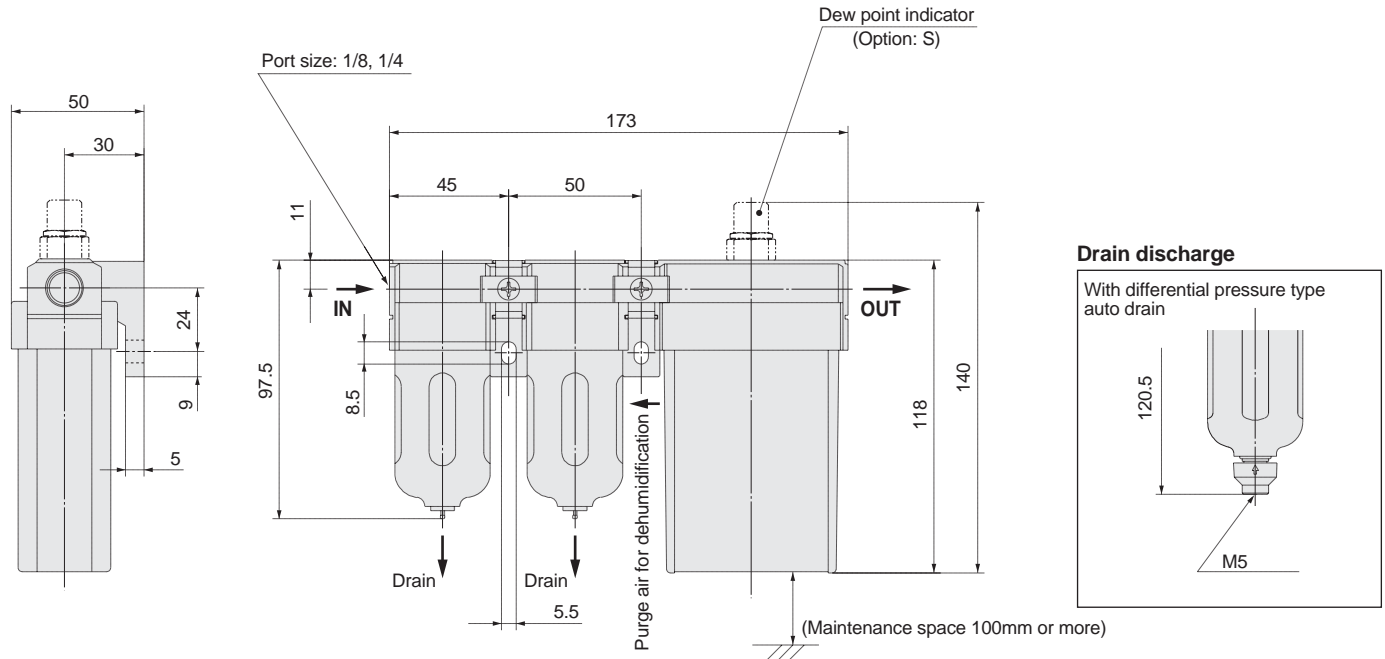

With fittings for purge air discharge (Option: P)

Purge air discharge tubing port for dew point indicator
Applicable tube O.D.: $\varnothing 8$

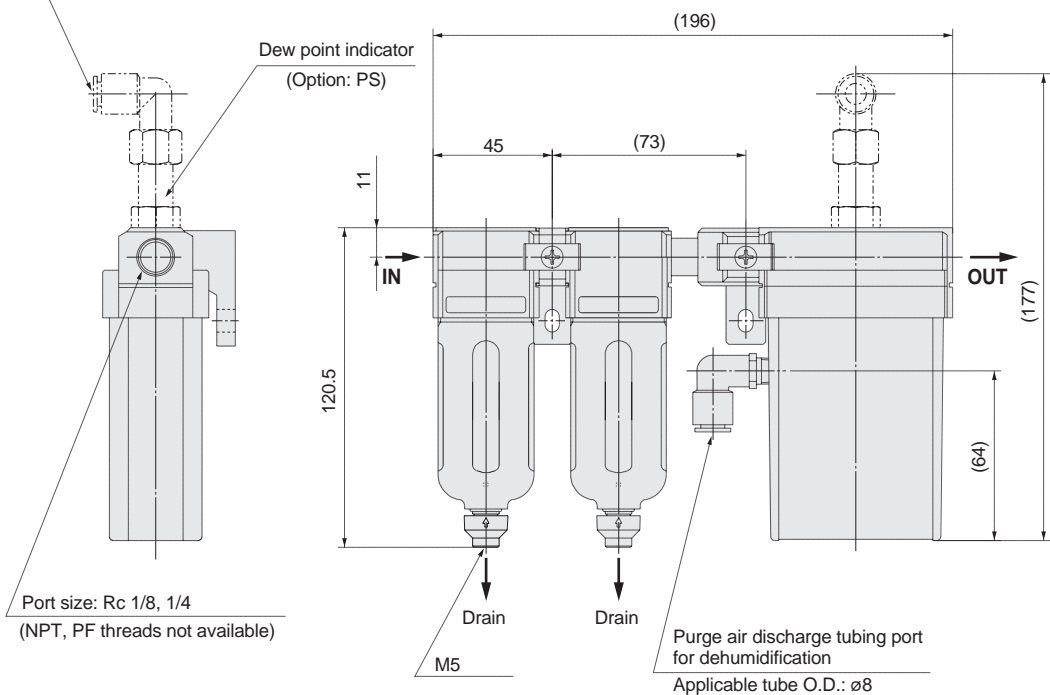

HA

IDG

AMG

AFF

AM

FQ1

Related products

Series IDG

Dimensions (M Type)

IDG10M, 20M
IDG10HM, 20HM

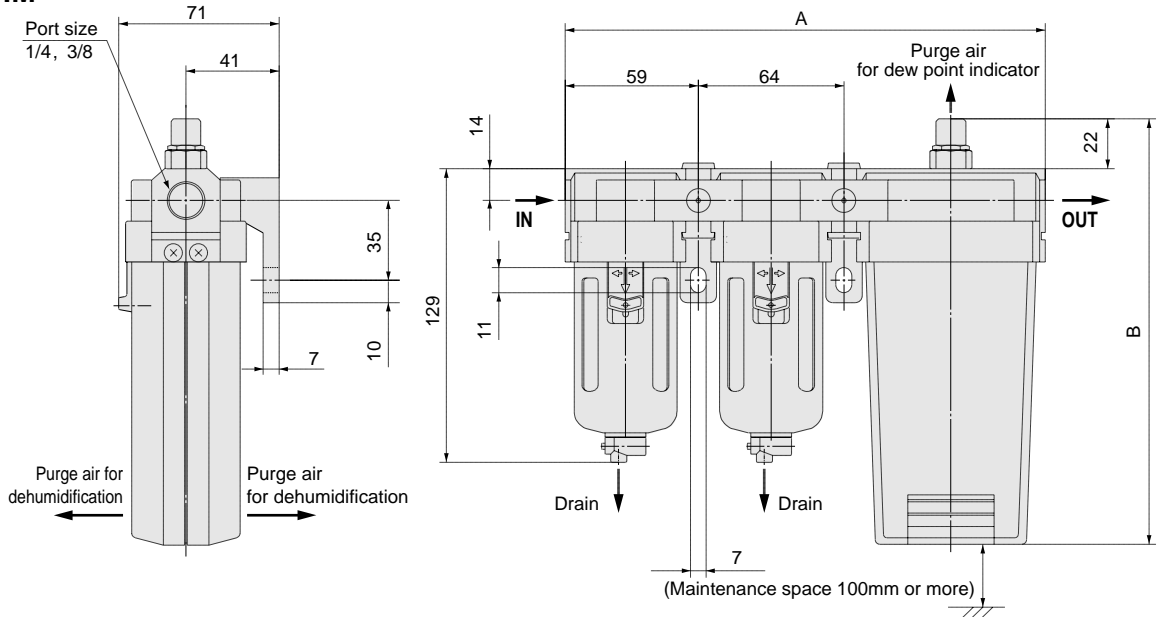

Drain discharge

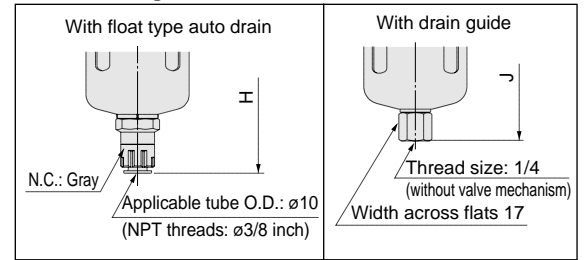

With fittings for purge air discharge (Option: P)

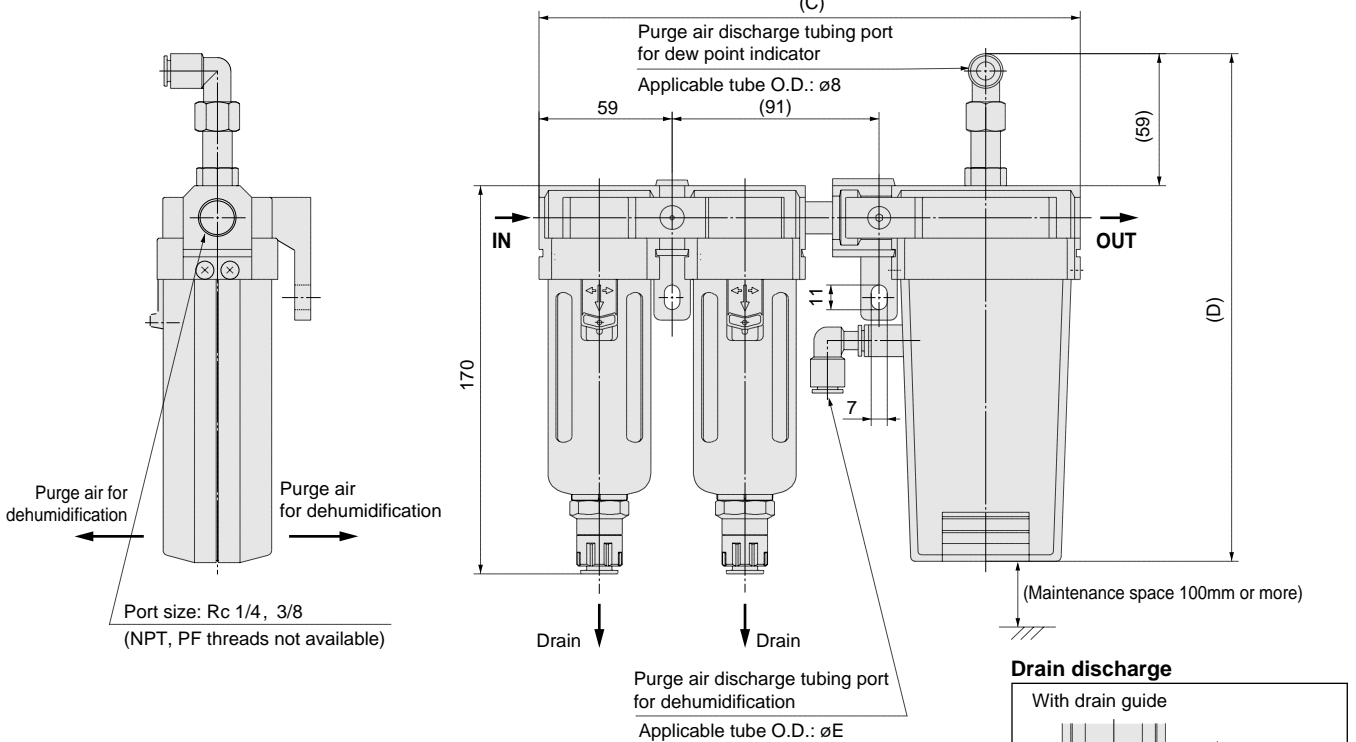

Drain discharge

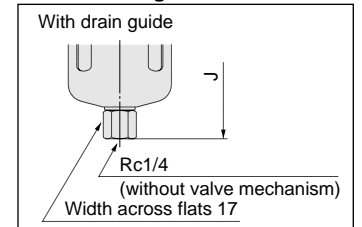

Model	A	B	Option: P			With float type auto drain H	With drain guide J
			C	D	E		
IDG10M, 10HM	211	187	238	224	8	170	135
IDG20M, 20HM	241	212	268	249	10		

**IDG30M, 50M
IDG30HM, 50HM
IDG30LM, 50LM**

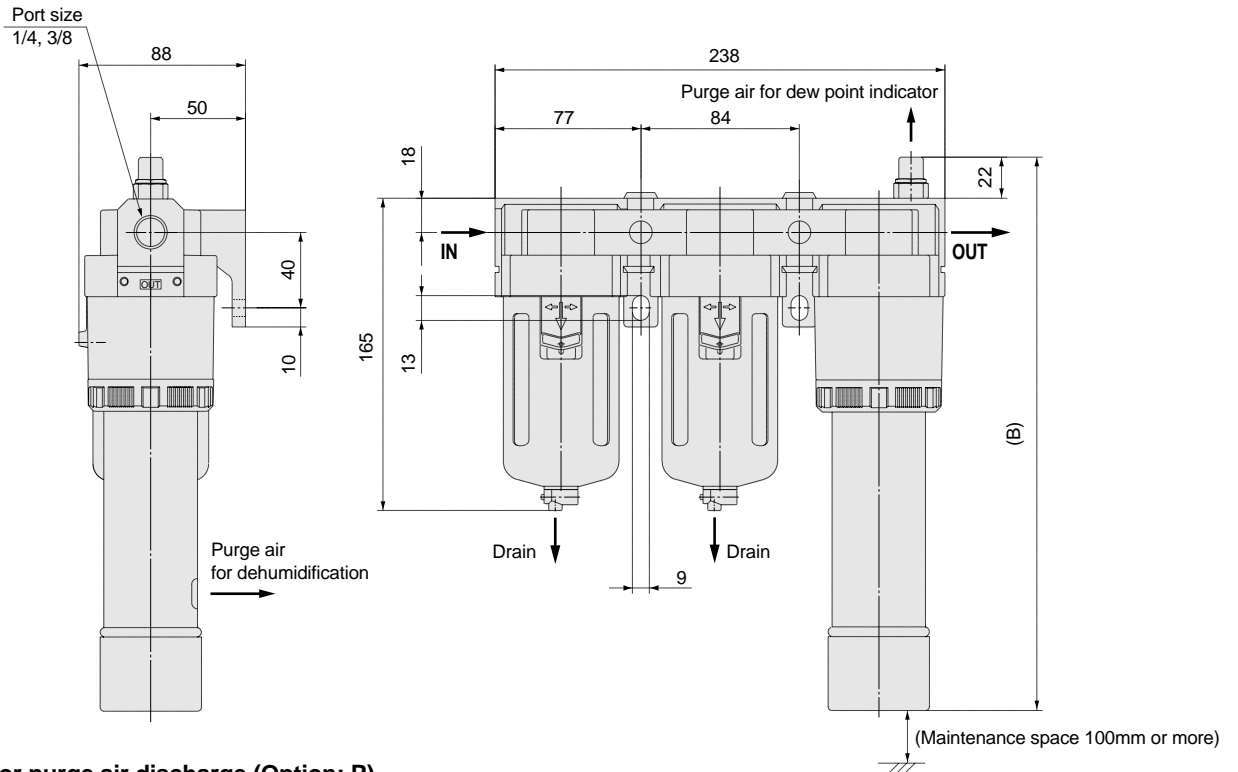

With fittings for purge air discharge (Option: P)

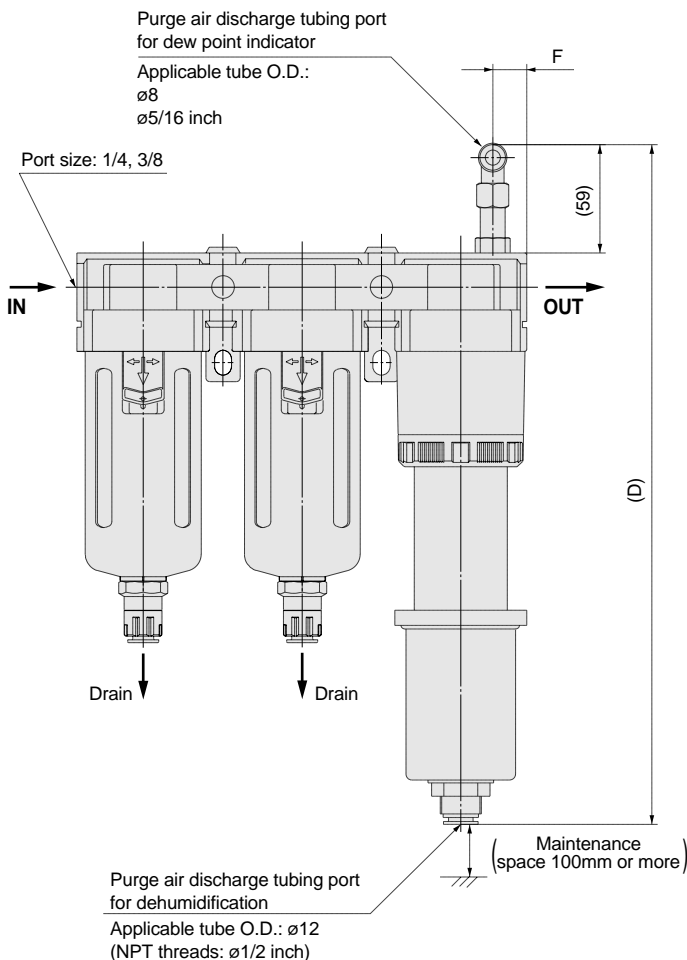

Model	B	Option: P		With float type auto drain	With drain guide
		D	F	H	J
IDG30M, 30HM, 30LM	293	361	18	206	171
IDG50M, 50HM, 50LM	337	405			

Drain discharge

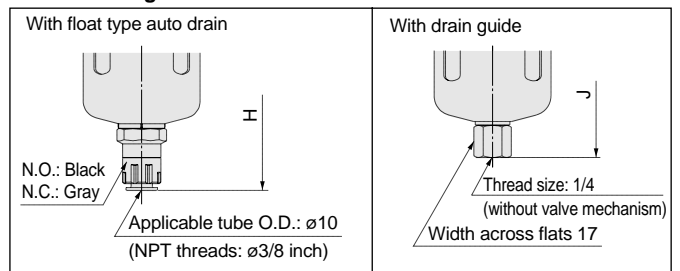

HA

IDG

AMG

AFF

AM

FQ1

Related products

Series IDG

Dimensions (M Type)

IDG60M, 75M, 100M
IDG60HM, 75HM, 100HM

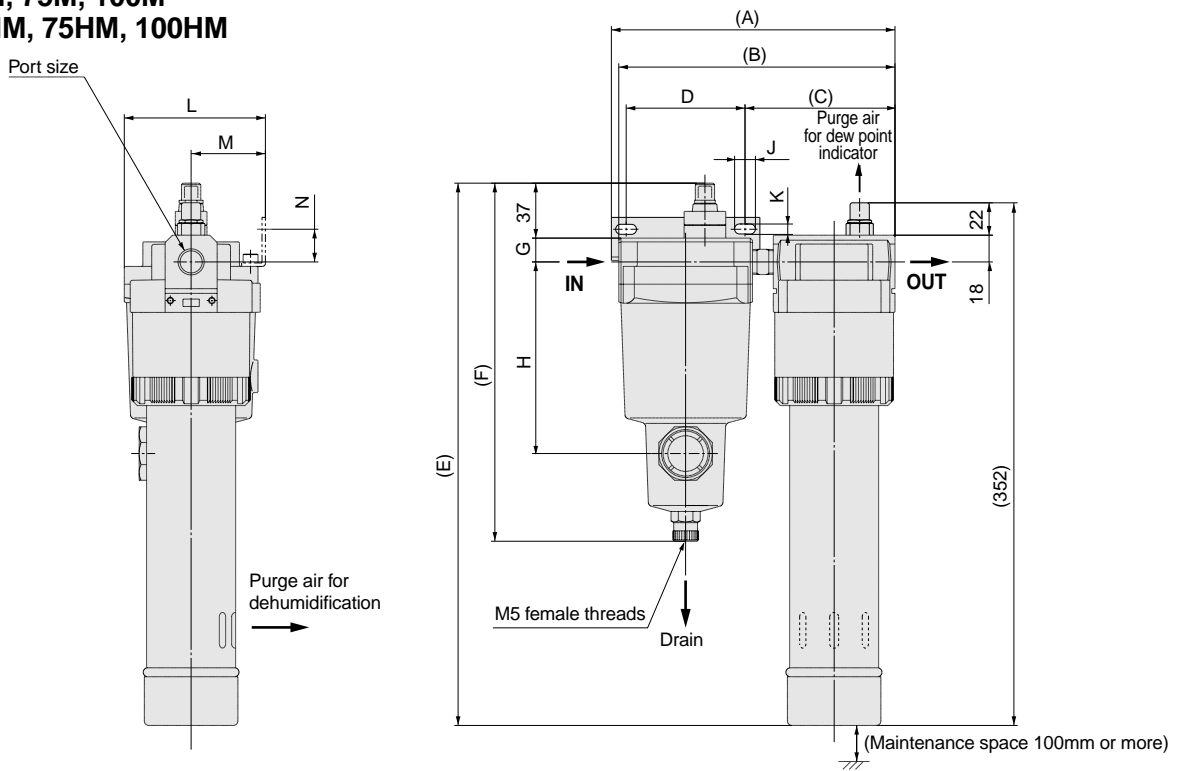

With fittings for purge air discharge (Option: P)

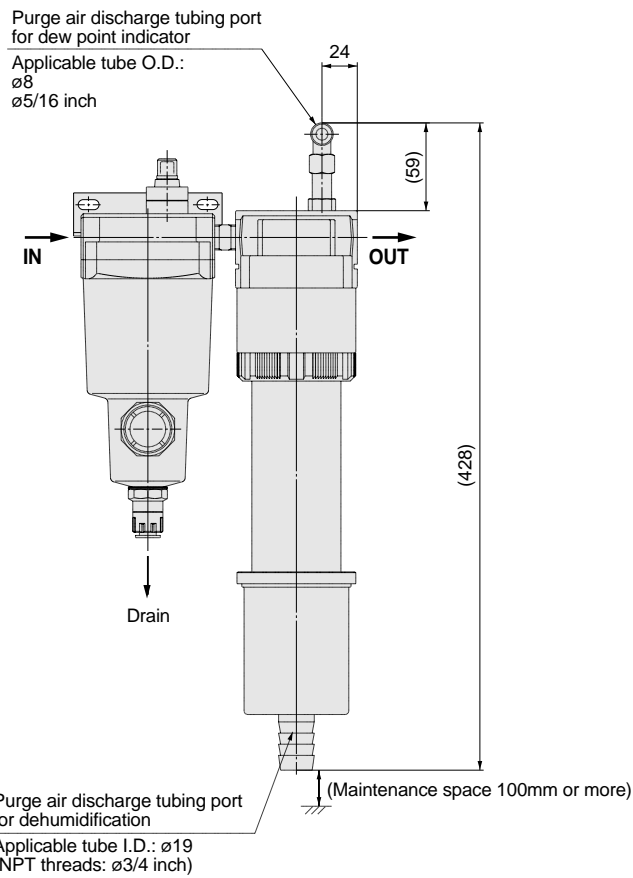

Drain discharge

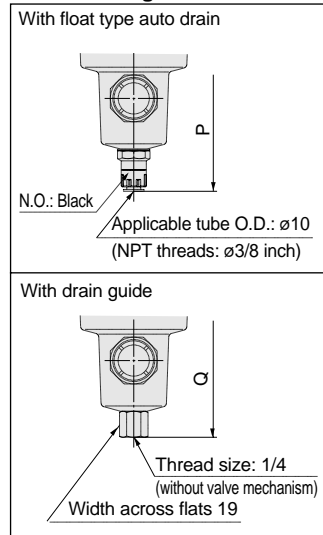

Model	Port size	A	B	C	D	E	F	G	H	K	L	M	N	With float type auto drain	With drain guide
														P	Q
IDG60M, 60HM	3/8, 1/2	191	186	101	80	365	241	16	129	7	95	50	22	255	241
IDG75M, 75HM, 100M, 100HM	1/2	204	202	104	90	368	262	19	147	9	108	55	25	276	262

IDG60LM, 75LM, 100LM IDG60SM, 75SM, 100SM

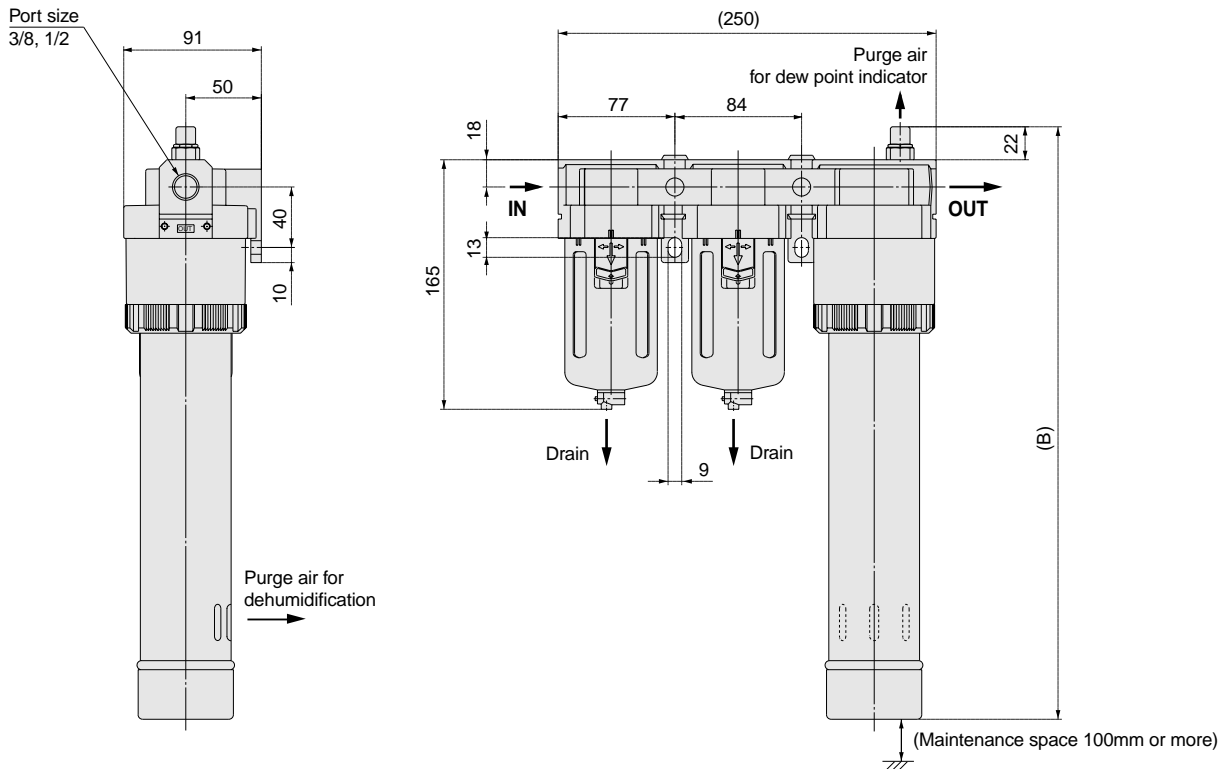

With fittings for purge air discharge (Option: P)

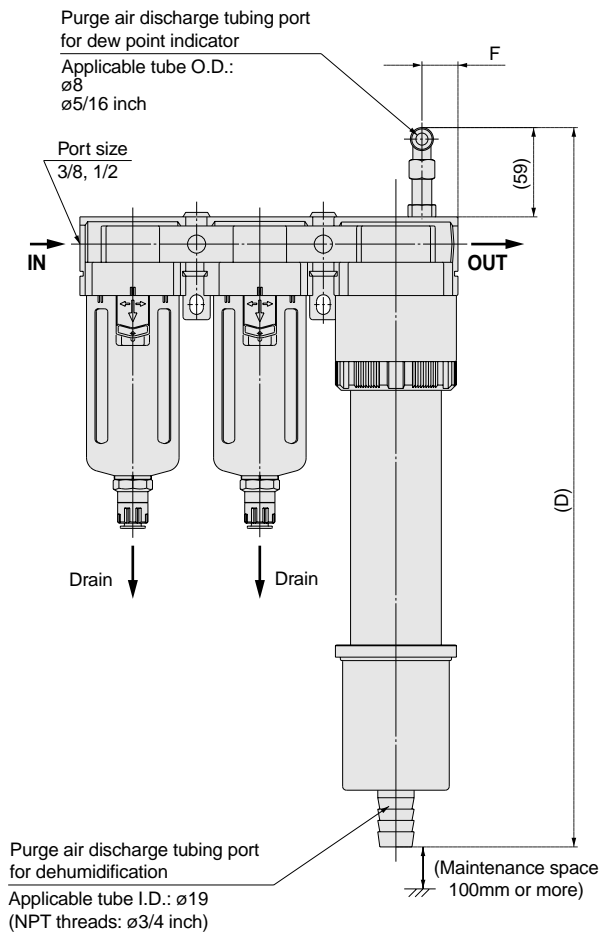

Drain discharge

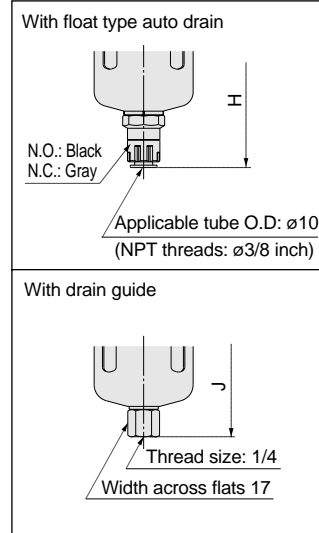

Model	B	Option: P		With float type auto drain	With drain guide
		D	F	H	J
IDG60LM, 60SM	392	468	24	206	171
IDG75LM, 75SM	472	548			
IDG100LM, 100SM	542	618			

HA

IDG

AMG

AFF

AM

FQ1

Related products

Series IDG

Dimensions (V Type)

IDG3V, 5V
IDG3HV, 5HV

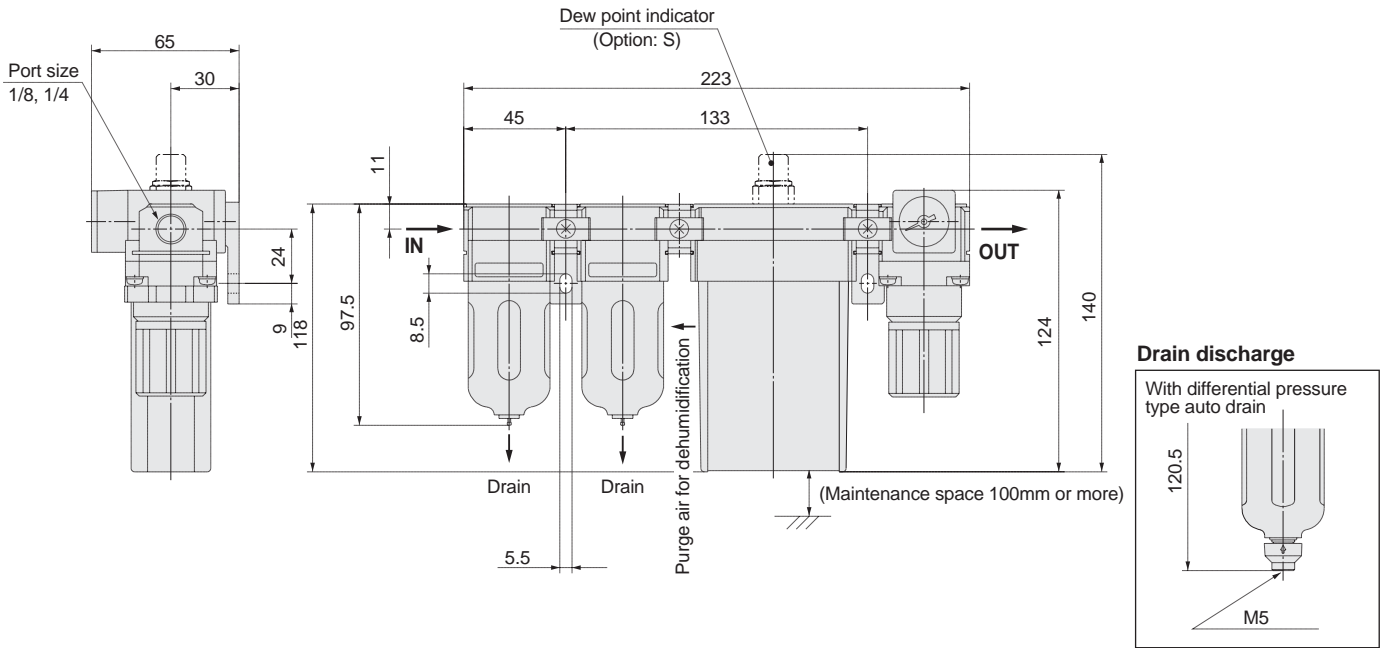

IDG10V, 20V
IDG10HV, 20HV

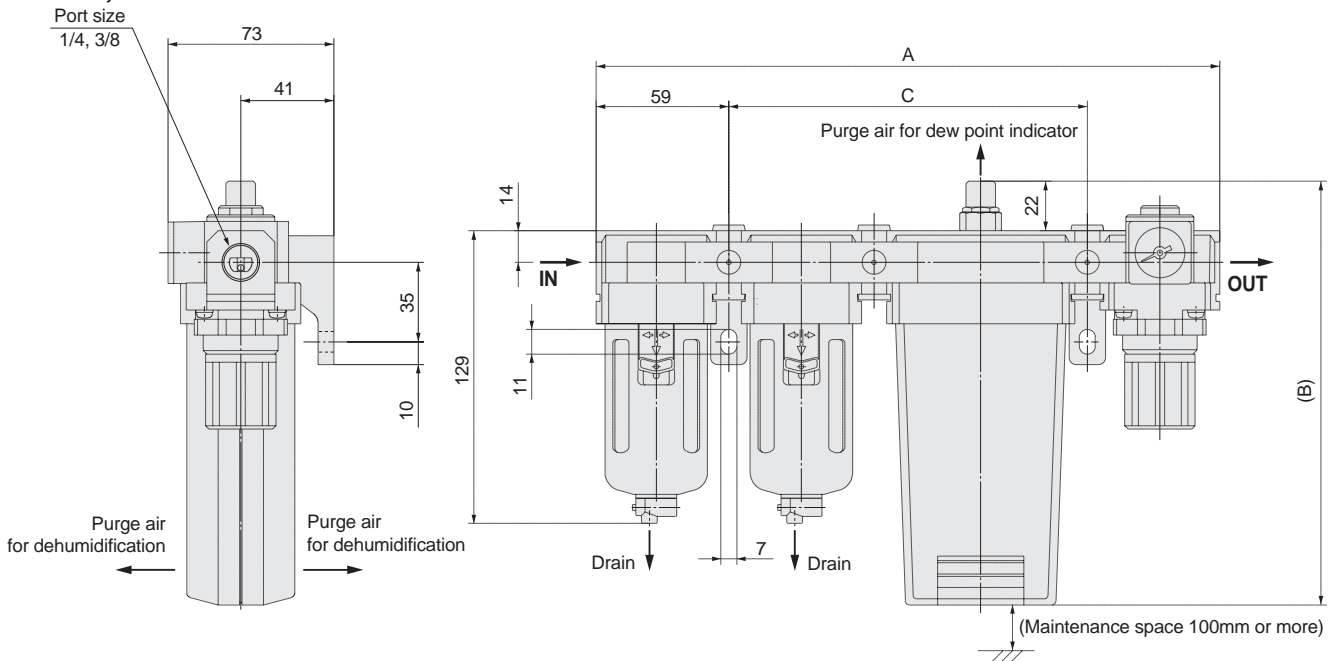

Model	A	B	C	With float type auto drain	With drain guide
				D	E
IDG10V, 10HV	275	187	158	170	135
IDG20V, 20HV	305	212	188		

DG30V, 50V
IDG30HV, 50HV
IDG30LV, 50LV

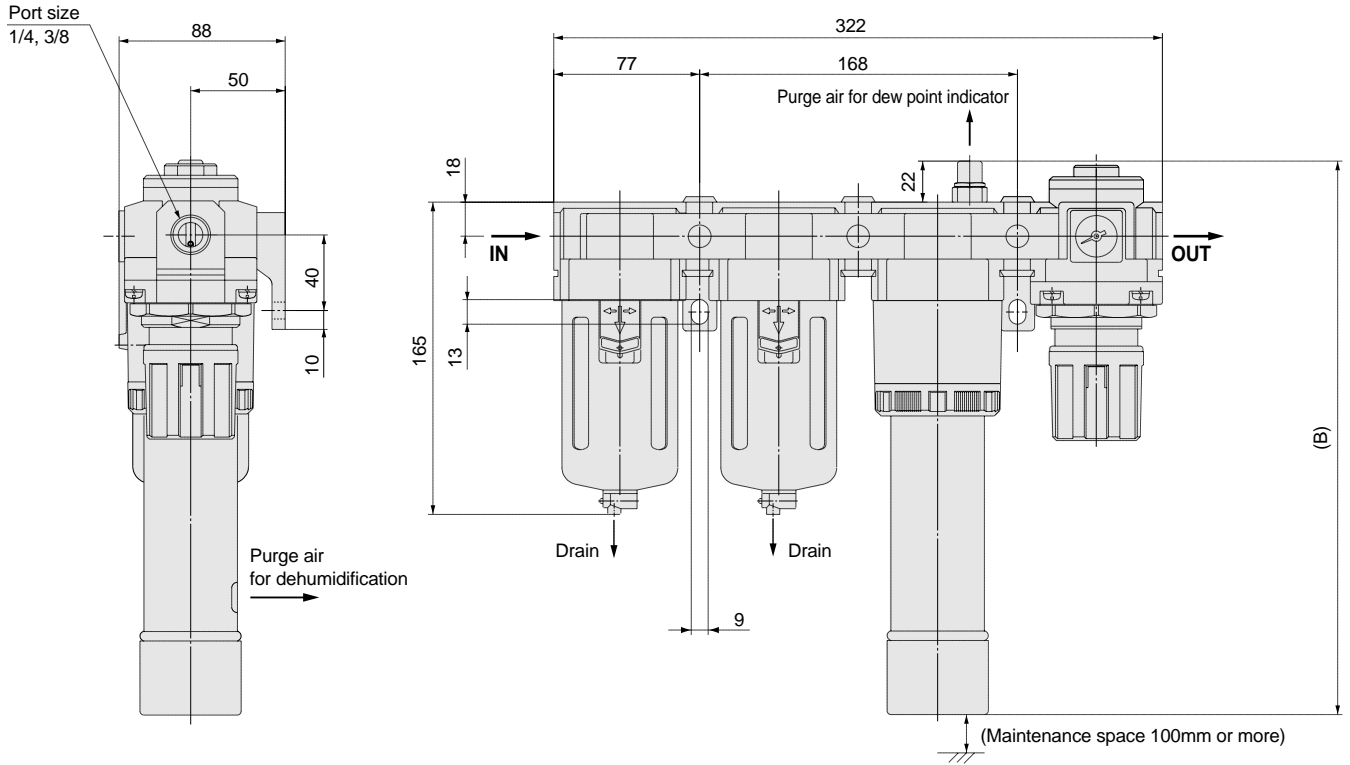

Model	B	With float type auto drain	With drain guide
		D	E
IDG30V, 30HV, 30LV	293	206	171
IDG50V, 50HV, 50LV	337		

Drain discharge

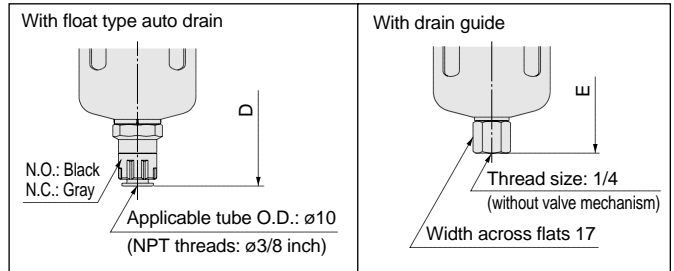

HA

IDG

AMG

AFF

AM

FQ1

Related products

Series IDG

Dimensions (V Type)

IDG60V, 75V, 100V
IDG60HV, 75HV, 100HV

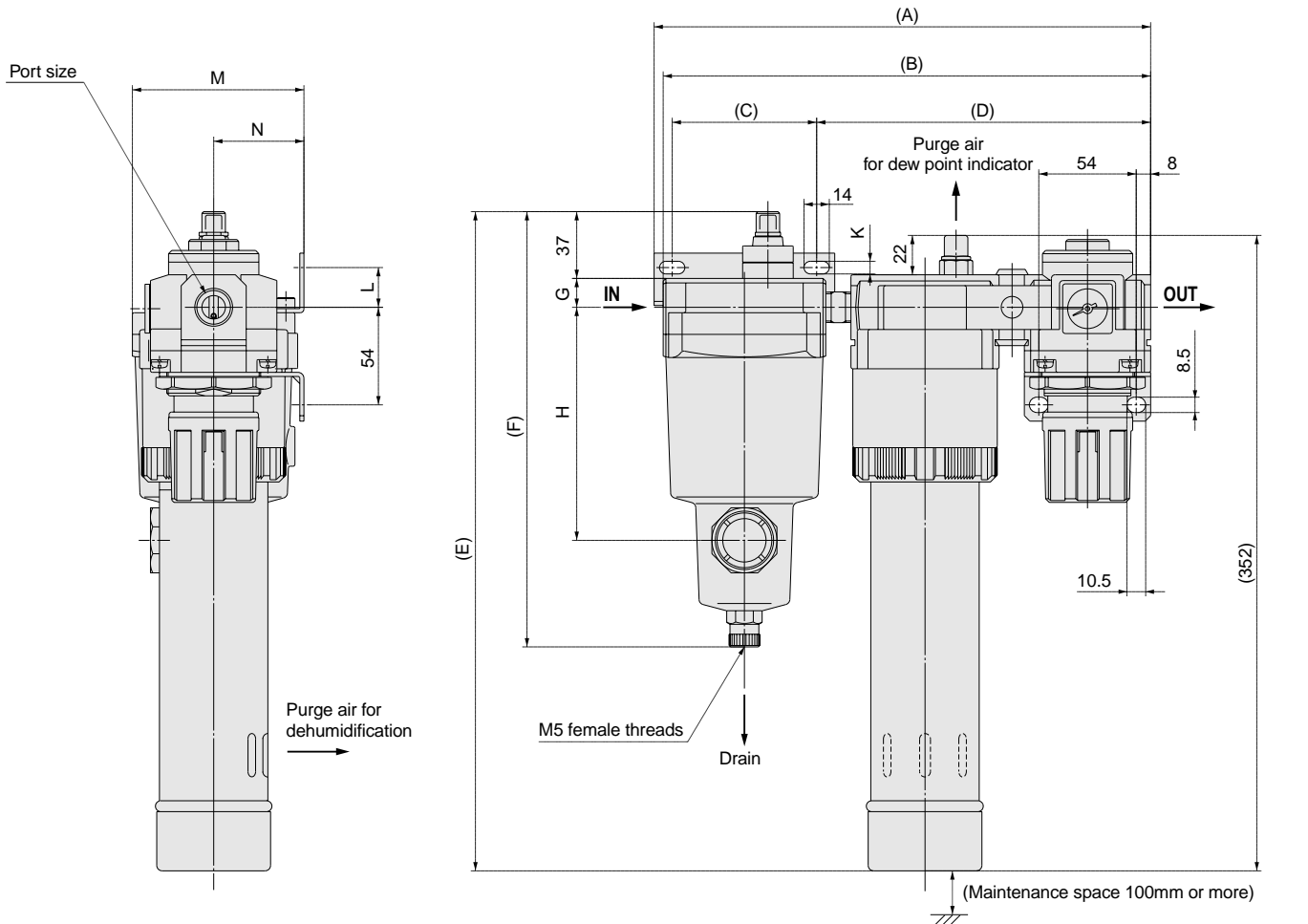

Drain discharge

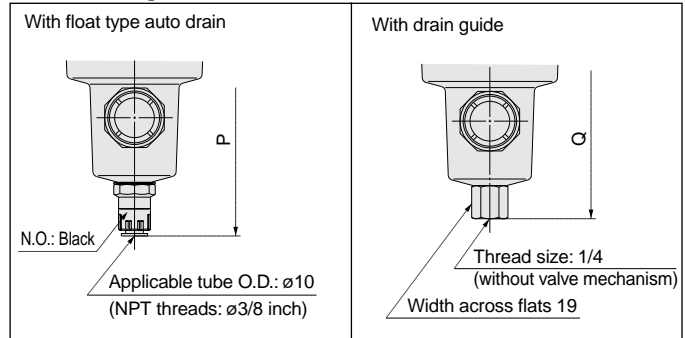

Model	Port size	A	B	C	D	E	F	G	H	K	L	M	N	With float type auto drain	With drain guide
														P	Q
IDG60V, 60HV	3/8, 1/2	275	270	80	185	365	241	16	129	7	22	95	50	255	241
IDG75V, 75HV, 100V, 100HV	1/2	288	286	90	188	368	262	19	147	9	25	108	55	276	262

IDG60LV, 75LV, 100LV IDG60SV, 75SV, 100SV

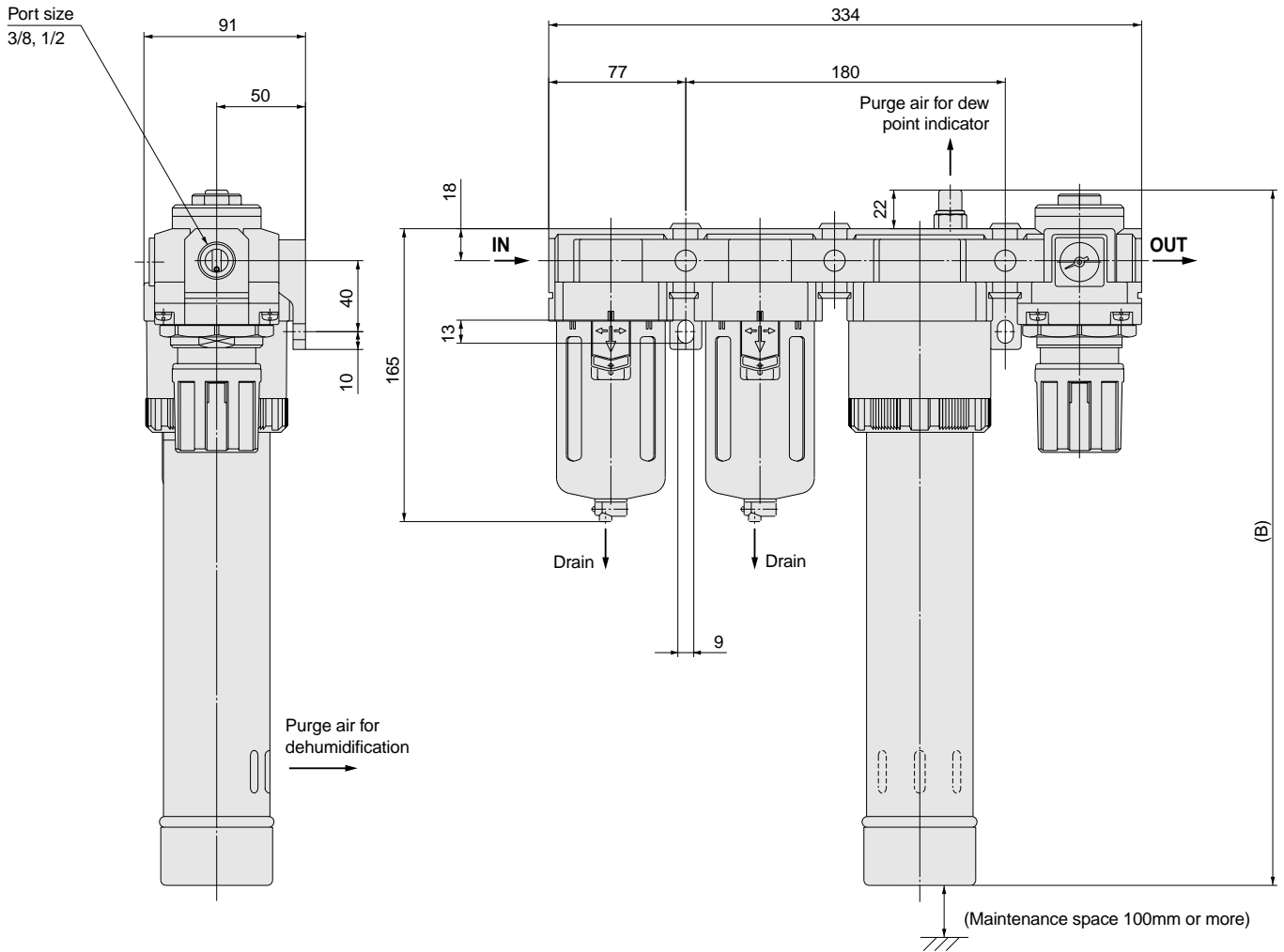

Drain discharge

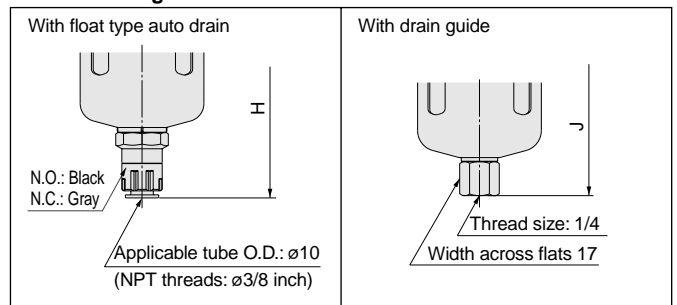

Model	B	With float type auto drain	With drain guide
		H	J
IDG60LV, 60SV	392	206	171
IDG75LV, 75SV	472		
IDG100LV, 100SV	542		

HA

IDG

AMG

AFF

AM

FQ1

Related products

Series IDG Order Made Specifications



Consult SMC regarding detailed dimensions, specifications and delivery times.

1 Element Service Indicator

An element service indicator is mounted on the micro mist separator with pre-filter (series AMH) to allow visual management of the element's clogging life. In addition, combination with a micro mist separator with pre-filter also provides a spatially compact design.

Applicable Models

Applicable model	IDG3M to IDG50M (standard dew point -20°C)
	IDG3HM to IDG50HM (standard dew point -15°C)
	IDG30LM to IDG50LM (standard dew point -40°C)

How to Order *Refer to ordering procedures for standard specifications on page 4.2-19.

IDG 10 M — 03 — X016

Size

3
5
10
20
30
50

Standard dew point*

Optional specifications*

Symbol	Contents	Size					
		3	5	10	20	30	50
Nil	Standard	●	●	●	●	●	●
R	Flow direction (right→left)	●	●	●	●	●	●
S	With dew point indicator	●	●	Standard equipment			

Drain discharge symbol

Drain discharge method		Size					
		3	5	10	20	30	50
Nil	Manual valve	●	●	●	●	●	●
C	N.C. auto drain	●	●	●	●	●	●
D	N.O. auto drain	●	●	●	●	●	●
J	Drain guide (aperture 1/4, without valve)	●	●	●	●	●	●

Port size*
Note) IDG50M and 50HM are 03 only.

Thread type*

Component equipment
Micro mist separator with pre-filter
Membrane air dryer

Component equipment	Size and standard dew point									
	3, 3H	5, 5H	10, 10H	20, 20H	30, 30H	30L	50, 50H	50L		
Micro mist separator with pre-filter	AMH150		AMH250		AMH150	AMH350	AMH150			

Clogging indication

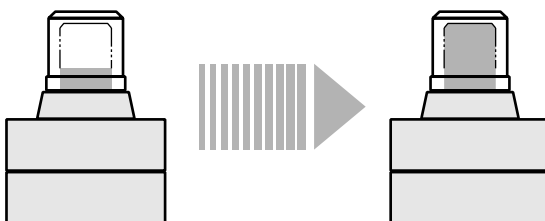

With differential pressure of 0.05MPa or less
(The tip of the indicator is just visible.)

With differential pressure of 0.1MPa or more
(The indicator is completely up to the top.)

Replace the element when the element service indicator's red indication reaches completely to the top.

The top of the indication window indicates differential pressure of approximately 0.1MPa. Furthermore, replace the element after two years of use even if the element service indicator's red indication does not reach the top.

The element service indicator is shipped mounted to the micro mist separator with pre-filter, and cannot be retrofitted or used with the single style.

Dimensions/With Element Service Indicator

IDG3M, 5M, 10M, 20M
IDG3HM, 5HM, 10HM, 20HM

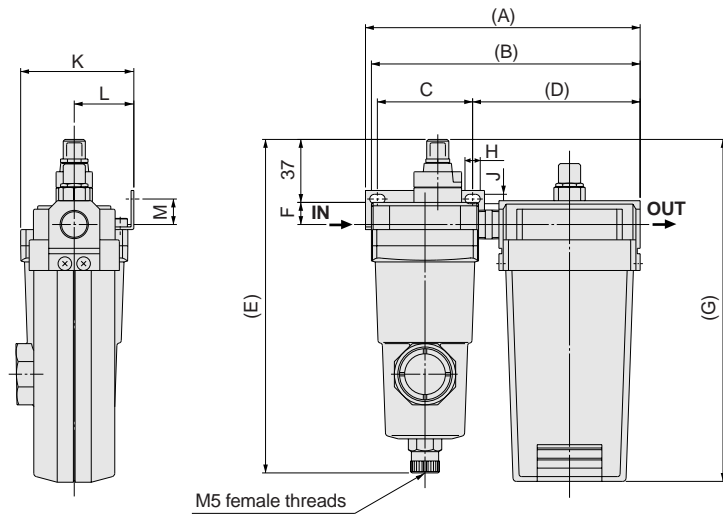

IDG30M, 50M
IDG30HM, 50HM
IDG30LM, 50LM

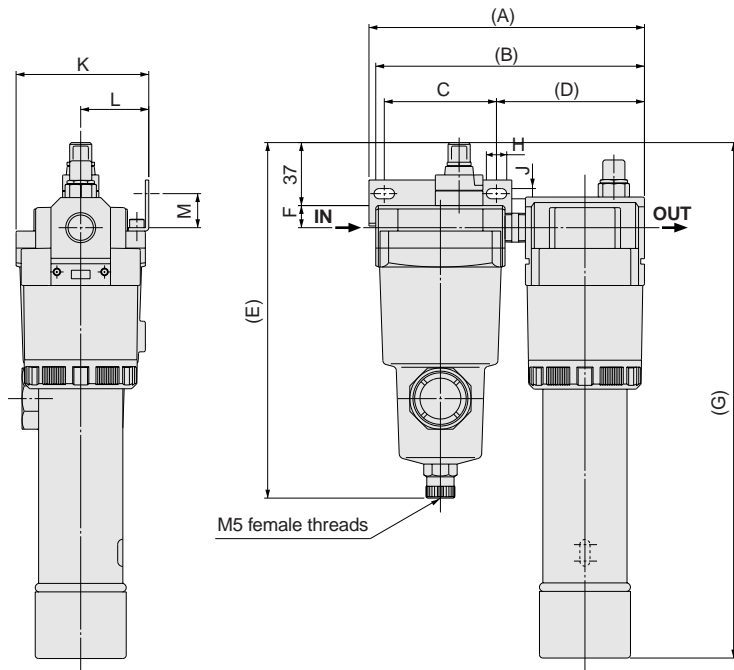

Drain discharge

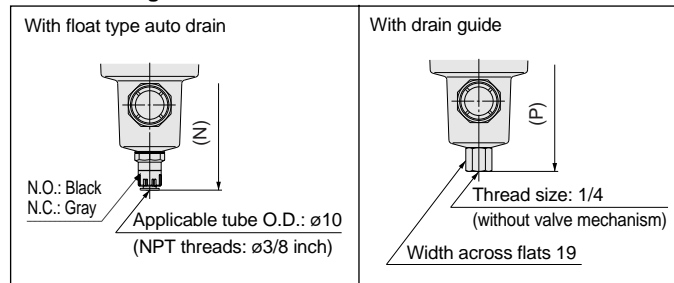

Model	Port size	A	B	C	D	E	F	G	H	J	K	L	M	With float type auto drain	With drain guide
														N	P
IDG3M, 3HM, 5M, 5HM	1/8, 1/4	150	146	56	87	196	13	157	9	5.5	66.5	35	15	210	196
IDG10M, 10HM	1/4, 3/8	162	158		99			201							
IDG20M, 20HM		205	201	66	130	226		12	6	78	40	20	223	209	
IDG30M, 30HM		162	158		87	303		9	5.5	70	35	15	210	196	
IDG30LM		149	145	56	86	196	9	5.5	70	35	15	210	196		
IDG50M, 50HM	3/8	177	172	80	87	241	16	350	14	7	95	50	22	255	241
IDG50LM	1/4, 3/8	149	145	56	86	196	13	347	9	5.5	70	35	15	210	196

HA□

IDG

AMG

AFF

AM□

FQ1

Related products

Series IDG Order Made Specifications



Consult SMC regarding detailed dimensions, specifications and delivery times.

2 With Micro Mist Separator Regulator (Series AWD)

This can be used when very clean air is required (supply for air bearings, semiconductor parts blow, etc.). The V type regulator (AR) is modified to produce the micro mist separator regulator (AWD).

Specifications

Outlet air filtration degree	0.01μm (95% filtered particle diameter)
Outlet air oil mist concentration	Max. 0.1mg/m ³ (ANR) (0.08ppm) ^{Note 1)} (prior to oil saturation 0.01mg/m ³ (ANR) or less (0.008ppm or less))

Note 1) With inlet air oil mist concentration of 30mg/m³ (ANR) (24ppm)

Applicable models

Applicable model	IDG3V to IDG50V (standard dew point -20°C) IDG3HV to IDG50HV (standard dew point -15°C) IDG30LV to IDG100LV (standard dew point -40°C) IDG60SV to IDG100SV (standard dew point -60°C)
------------------	--

How to Order * Refer to order procedures for standard specifications on page 4.2-18.

IDG 10 [] V [] [] 03 [] [] [] X017

Size

3
5
10
20
30
50
60
75
100

Standard dew point*

Optional specifications*

Symbol	Contents	Size									
		3	5	10	20	30	50	60	75	100	
Nil	Standard	●	●	●	●	●	●	●	●	●	
R	Flow direction (right→left)	●	●	●	●	●	●	●	●	●	
S	With dew point indicator	●	●	Standard equipment							

• Drain discharge symbol*

• Port size*

• Thread type*

• Component equipment

- Mist separator
- Micro mist separator
- Membrane air dryer
- Micro mist separator regulator

Component equipment	Size									
	3	5	10	20	30	50	60 <small>Note)</small>	75 <small>Note)</small>	100 <small>Note)</small>	
Mist separator	AFM2000		AFM3000		AFM4000					
Micro mist separator	AFD2000		AFD3000		AFD4000					
Micro mist separator regulator	AWD2000		AWD3000		AWD4000					

Note) Standard dew point symbols L (-40°C) and S (-60°C) only

Dimensions/With Micro Mist Separator Regulator

IDG3V, 5V, 10V, 20V
IDG3HV, 5HV, 10HV, 20HV

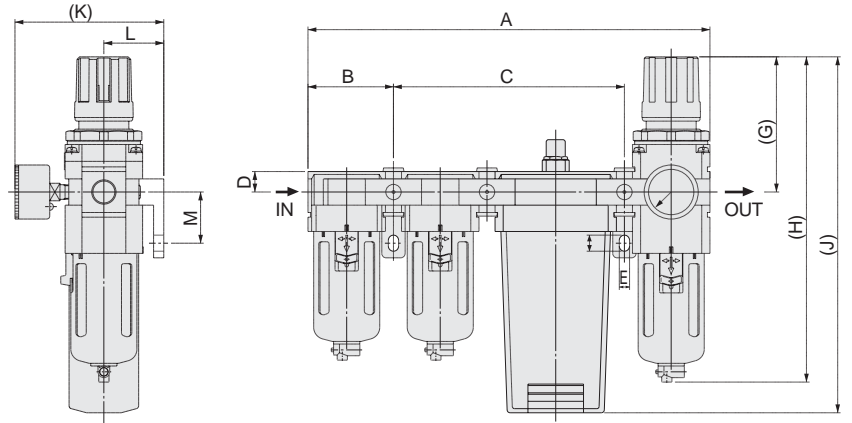

IDG30V, 50V
IDG30HV, 50HV
IDG30LV, 50LV, 60LV, 75LV, 100LV
IDG60SV, 75SV, 100SV

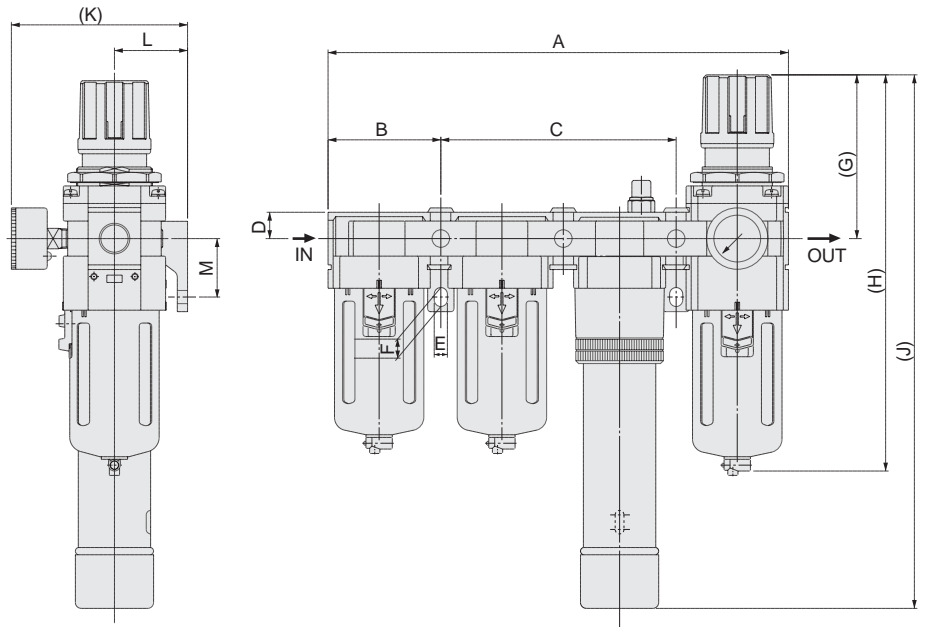

Drain discharge

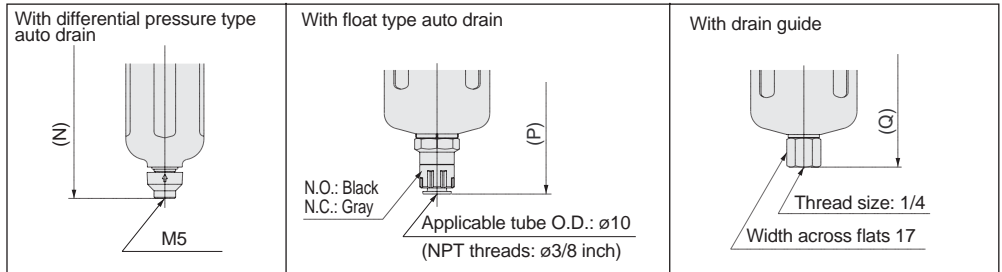

Model	Port size	A	B	C	D	E	F	G	H	J	K	L	M	With auto drain		With drain guide
														Differential pressure type	Float type	
														N	P	
IDG3V, 3HV, 5V, 5HV	1/8, 1/4	224	45	133	11	5.5	8.5	78	179.5	185	87	30	24	201.5	—	—
IDG10V, 10HV	1/4, 3/8	275	59	158	14	7	11	92.5	222.5	244	102	41	35	—	263.5	228.5
IDG20V, 20HV		305		269						—						
IDG30V, 30HV		365		—						—						
IDG50V, 50HV	3/8, 1/2	327	77	161	18	9	13	112	274	409	121	50	40	—	315	280
IDG60LV, 60SV										464				—		
IDG75LV, 75SV										544				—		
IDG100LV, 100SV										614				—		

HA

IDG

AMG

AFF

AM

FQ1

Related products

Series IDG Model Selection

Model Selection

Step 1 Confirmation of operating conditions

Outlet air flow rate Q [ℓ/min (ANR)]
Outlet air atmospheric pressure dew point [°C]
(When it is necessary to convert from the dew point under pressure, refer to the dew point temperature conversion chart below.)
Inlet air pressure [MPa]
Inlet air temperature [°C]
Allowable pressure drop ΔP [MPa]
Compressed air supply capacity Q [ℓ/min (ANR)]

Dew point temperature conversion chart

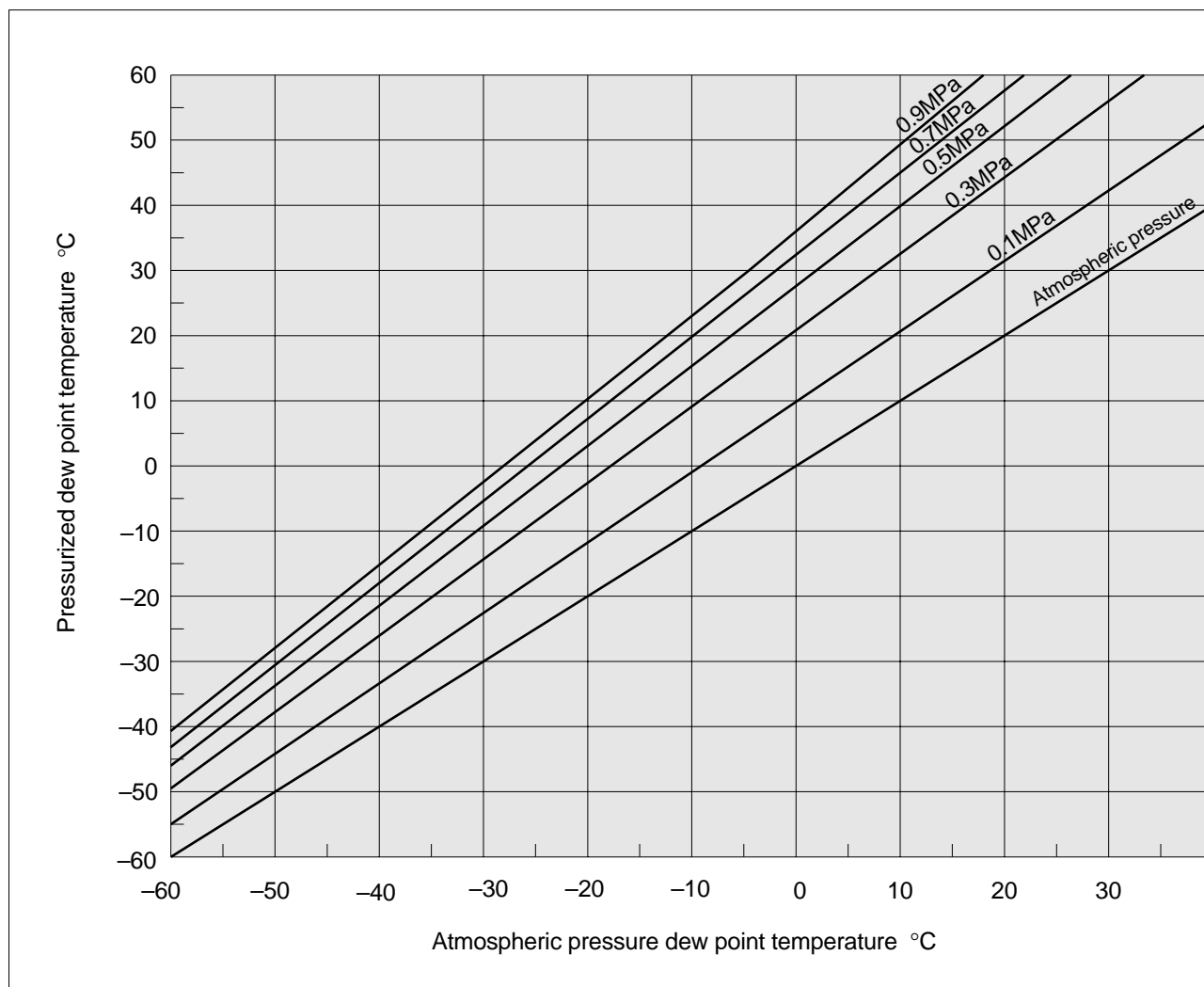

Step 2 Tentative determination of membrane air dryer model

Tentative determination of model from performance charts (refer to pages 4.2-3, 4.2-5, 4.2-8, 4.2-9, 4.2-12 and 4.2-13)

Note: When the inlet air temperature is not 25°C, make a tentative model determination from the performance charts referring to the information below.
For each increase of 1°C in the inlet air temperature, the outlet air atmospheric pressure dew point increases by approximately 0.8°C.

(Inlet air pressure: 0.7MPa
Outlet air flow rate: At rated flow rate)

Step 3 Confirmation of purge air flow rate

Read from purge air flow rate charts (refer to page 4.2-42)

Conditions: Membrane air dryer model
Inlet air pressure [MPa]

Step 4 Calculation of inlet air flow rate Q₁, and confirmation of compressed air supply capacity

Inlet air flow rate Q₁ [ℓ/min (ANR)] =
Outlet air flow rate [ℓ/min (ANR)] + Purge air flow rate [ℓ/min (ANR)]

Step 1 ← NO
Confirmation of compressed air supply capacity
Q ≥ Q₁

Review operating conditions.

YES

Step 5

Step 5 Confirmation of pressure drop ΔP₁ [MPa]

Single style (refer to pages 4.2-40 and 4.2-41)
Unit style (refer to pages 4.2-23 and 4.2-24)

Conditions: Membrane air dryer model
Inlet air flow rate Q₁ [ℓ/min (ANR)]
Inlet air pressure [MPa]

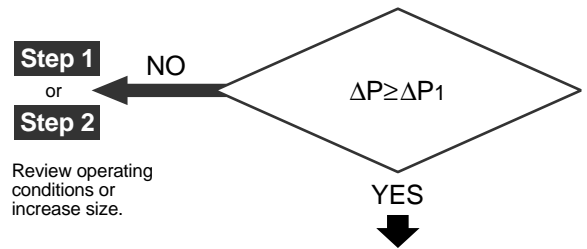

Step 6 Examine drain discharge method (for units), accessories and optional specifications

Single style (refer to pages 4.2-3, 4.2-7, 4.2-11 and 4.2-13)
Unit style (refer to page 4.2-18)

Model Determination

HA

IDG

AMG

AFF

AM

FQ1

Related products

Flow Rate Characteristics

IDG1 (standard dew point -20°C)

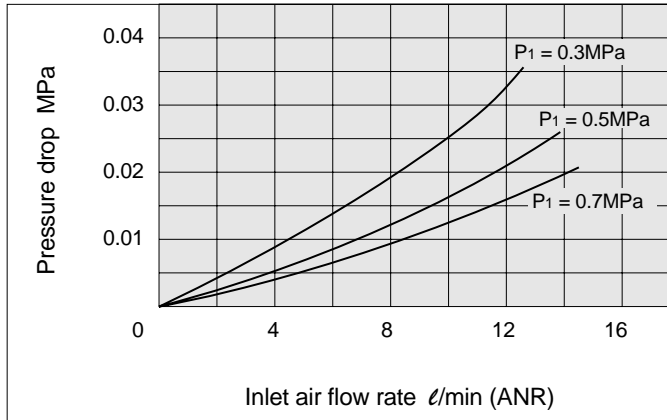

IDG3 (standard dew point -20°C), **IDG3H** (standard dew point -15°C)

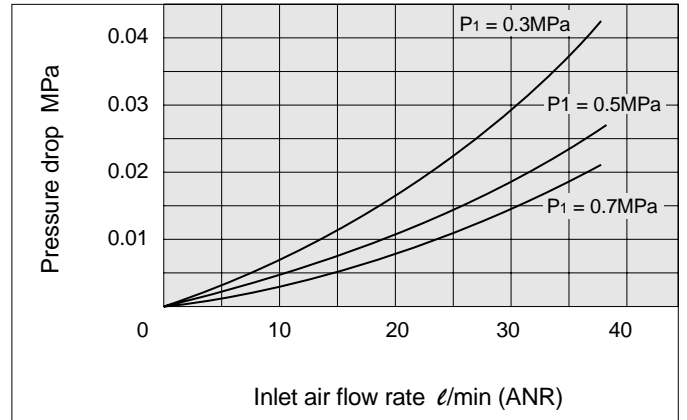

IDG5 (standard dew point -20°C), **IDG5H** (standard dew point -15°C)

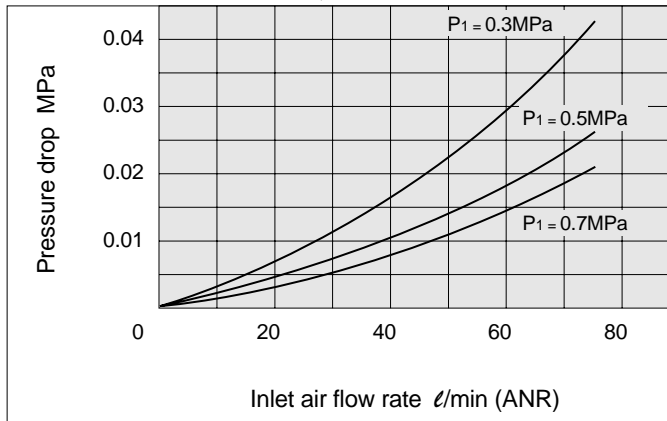

IDG10 (standard dew point -20°C), **IDG10H** (standard dew point -15°C)

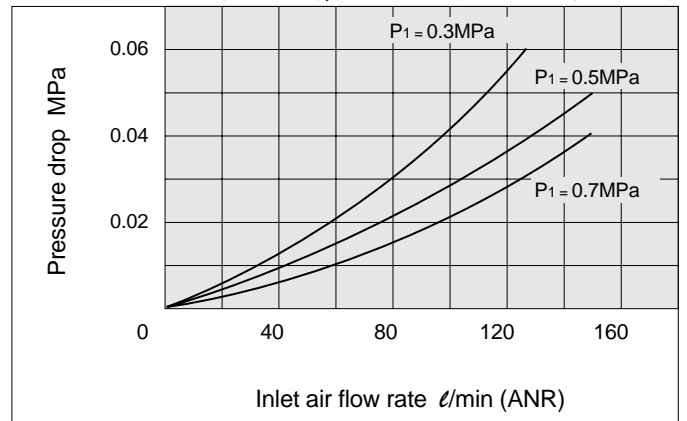

IDG20 (standard dew point -20°C), **IDG20H** (standard dew point -15°C)

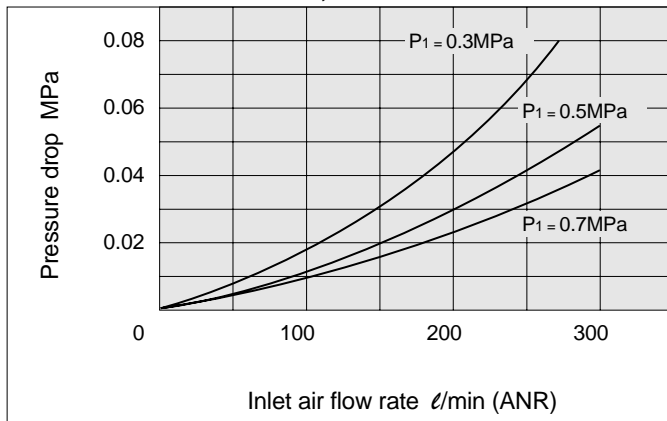

IDG30 (standard dew point -20°C), **IDG30H** (standard dew point -15°C), **IDG30L** (standard dew point -40°C)

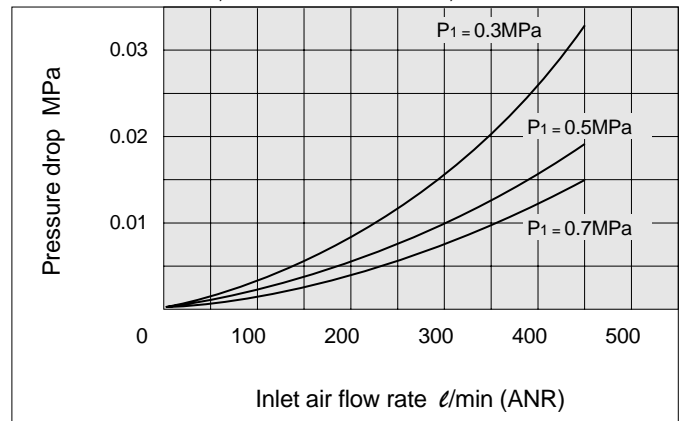

IDG50 (standard dew point -20°C), **IDG50H** (standard dew point -15°C), **IDG50L** (standard dew point -40°C)

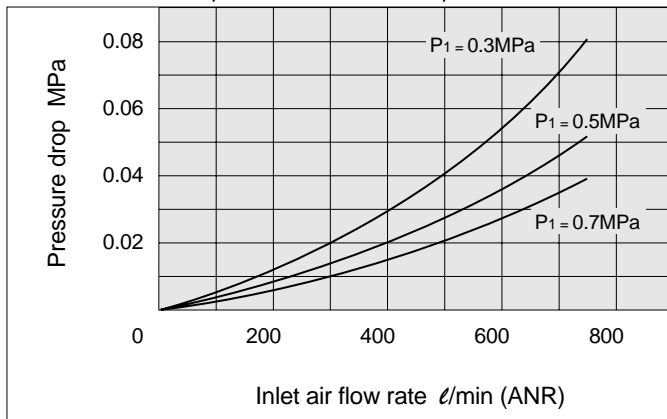

IDG60 (standard dew point -20°C), **IDG60H** (standard dew point -15°C)

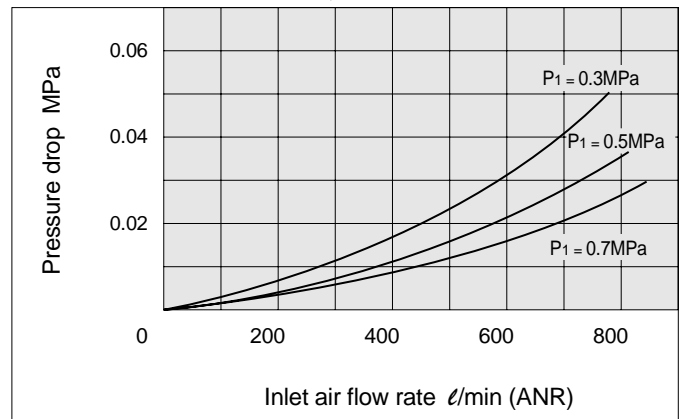

Membrane Air Dryer *Series IDG*

Conditions: Inlet air temperature 25°C, P_i: Inlet air pressure

IDG60L (standard dew point -40°C), **IDG60S** (standard dew point -60°C)

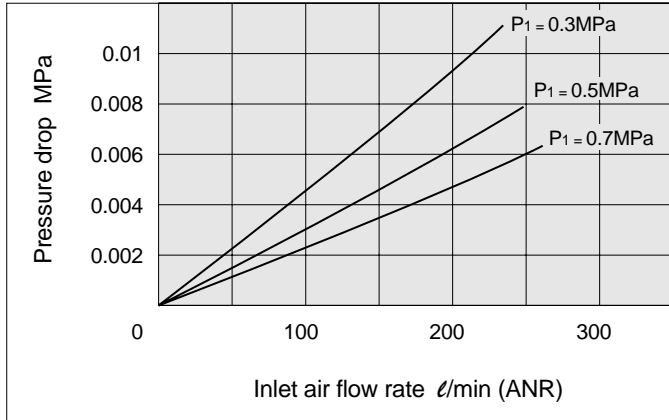

IDG75 (standard dew point -20°C), **IDG75H** (standard dew point -15°C)

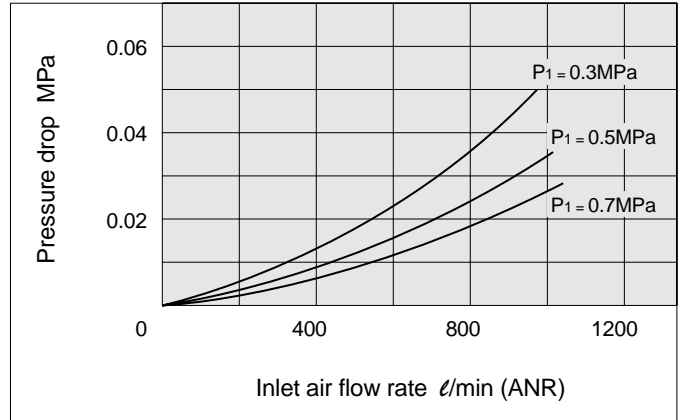

IDG75L (standard dew point -40°C), **IDG75S** (standard dew point -60°C)

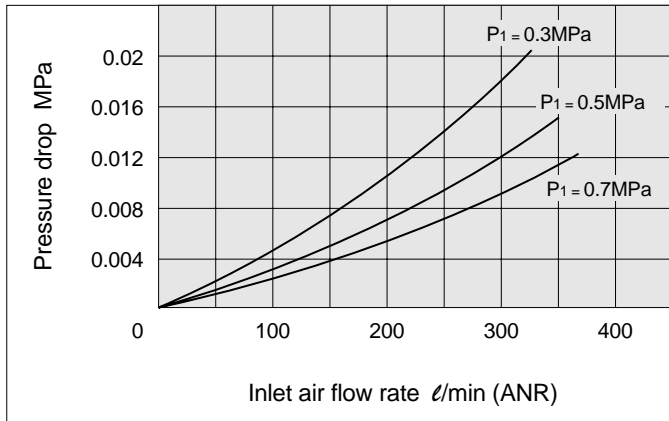

IDG100 (standard dew point -20°C), **IDG100H** (standard dew point -15°C)

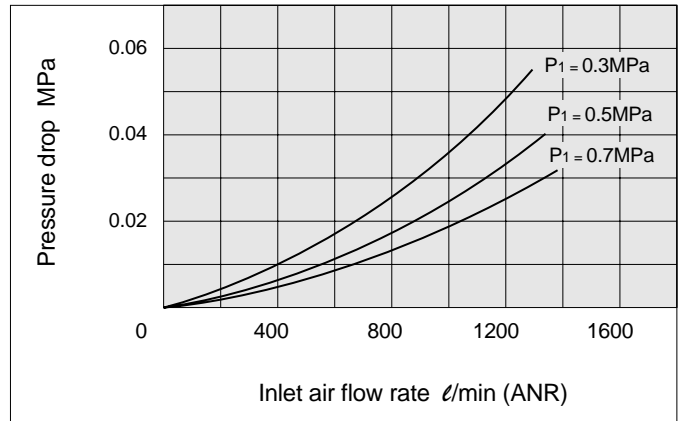

IDG100L (standard dew point -40°C), **IDG100S** (standard dew point -60°C)

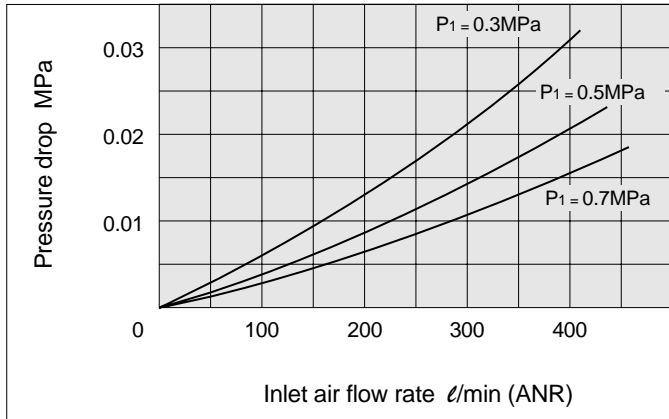

HA□

IDG

AMG

AFF

AM□

FQ1

Related products

Purge Air Flow Rate Charts

Condition: Inlet air temperature 25°C

IDG1, 3, 5, 10, 20 (standard dew point -20°C)
IDG3H, 5H, 10H, 20H (standard dew point -15°C)

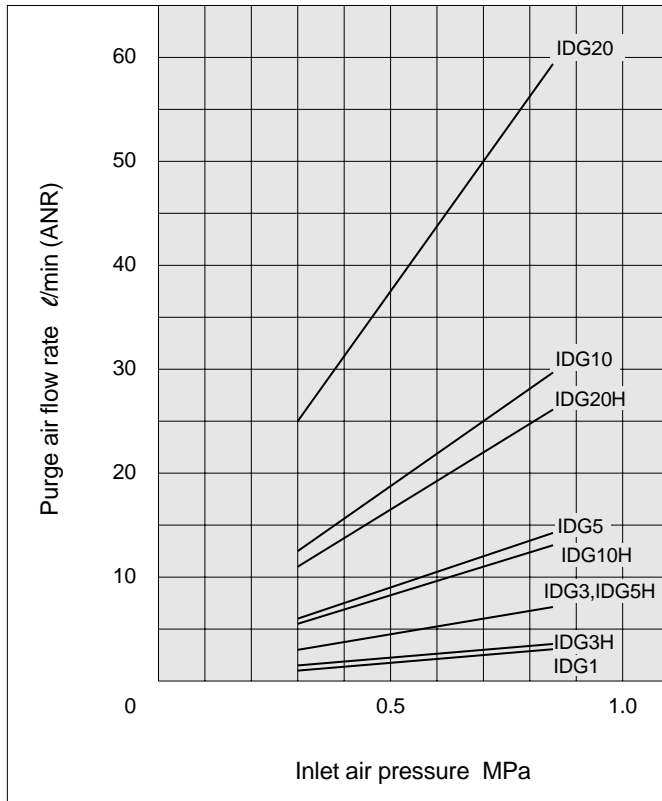

IDG30, 50 (standard dew point -20°C)
IDG30H, 50H (standard dew point -15°C)
IDG30L, 50L (standard dew point -40°C)

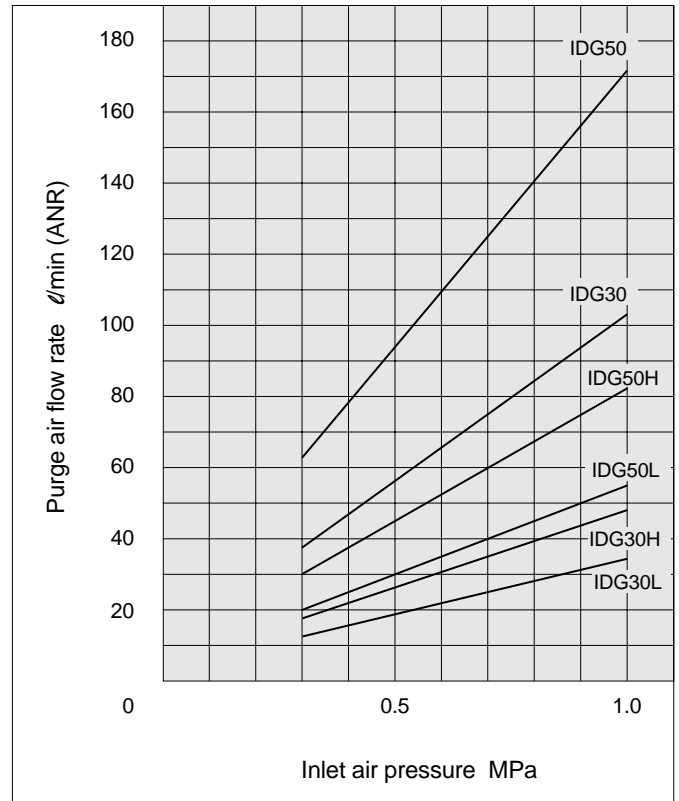

IDG60, 75, 100 (standard dew point -20°C)
IDG60H, 75H, 100H (standard dew point -15°C)

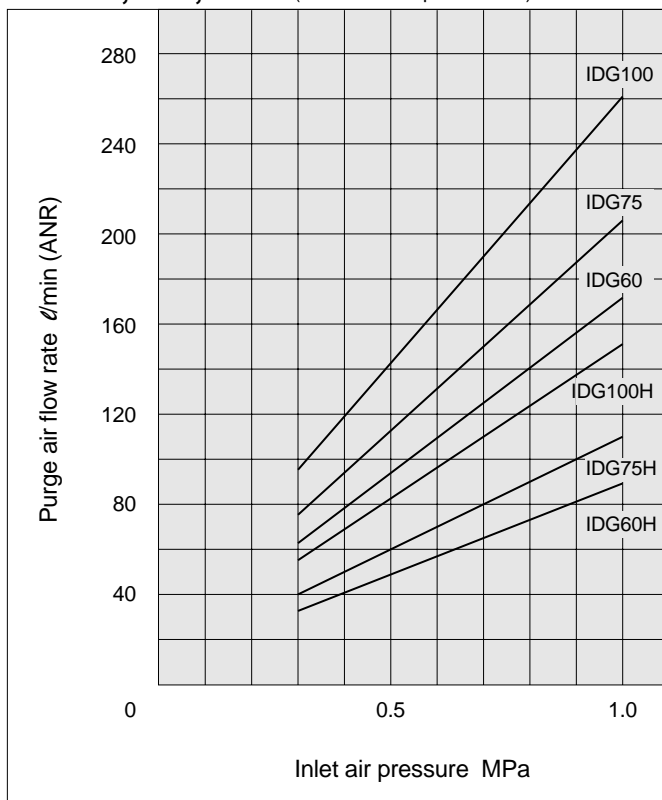

IDG60L, 75L, 100L (standard dew point -40°C)
IDG60S, 75S, 100S (standard dew point -60°C)

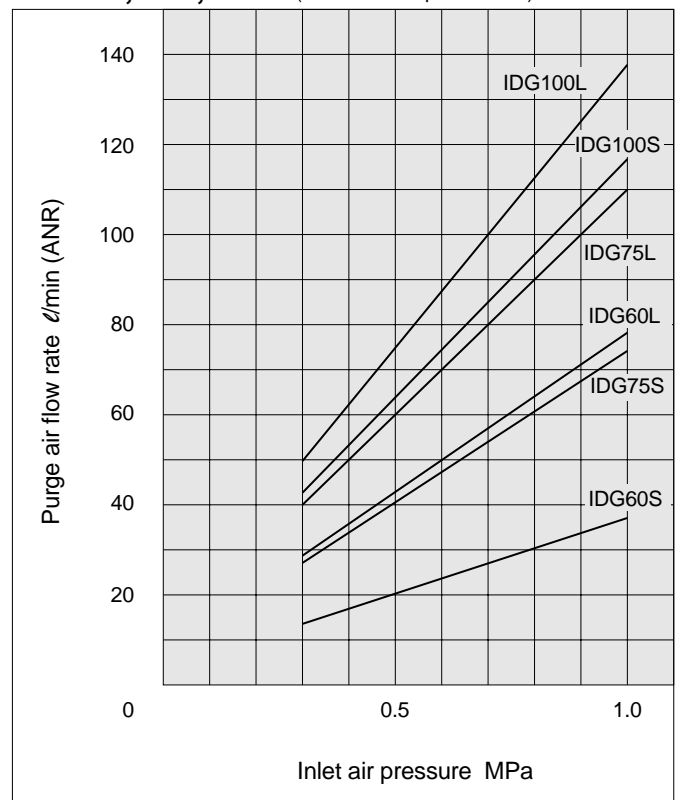



Series IDG

Specific Product Precautions 1

Be sure to read before handling.

Precautions on Design

⚠ Warning

1. Depending on the model and operating conditions, the oxygen ratio of the outlet air may drop below the prescribed standard.

Consult SMC in advance, as some models are not suitable for dehumidification of air for breathing.

⚠ Caution

1. Devise a layout which considers the position of purge air discharge ports.

Purge air is humid air. Devise a layout in which purge air will not cause trouble such as corrosion or malfunction of peripheral equipment.

2. When very clean air is required

(supply to air bearings, blowing of semiconductor parts, etc.) Install a micro mist separator or super mist separator on the downstream side (end terminal) of the membrane air dryer (unit).

Furthermore, grease is used inside the regulator that is used for units (V type). When very clean air is required, install a separator as mentioned above on the downstream side, or instead of a regulator, use the order made specification (refer to page 35) fitted with a micro mist separator regulator (series AWD).

3. Time to reach the rated dew point

A certain amount of time is required to reach the rated dew point after beginning the flow of air into the membrane air dryer. Using the times below as a guide, begin operating downstream equipment after reaching the rated dew point.

- Standard dew point -20°C, -15°C: Approx. 10min.
- Standard dew point -40°C: Approx. 30 min.*
- Standard dew point -60°C: Approx. 120 min.*

*This time can be shortened as described below.

- 1) Provide a valve on the downstream side of the membrane air dryer.
 - 2) Supply air with the valve closed. Only purge air flows into the membrane air dryer.
 - 3) After 15 minutes or more, open the valve and let air flow to the downstream equipment.
4. Dehumidification performance when inlet air temperature changes

The performance charts indicate an inlet air temperature of 25°C. See below for other temperatures.

For each increase of 1°C in the inlet air temperature, the outlet air atmospheric pressure dew point increases by approximately 0.8°C.

(Inlet air pressure: 0.7MPa, Outlet air flow rate: At rated flow rate)

Selection

⚠ Caution

1. Consider the purge air flow rate.

Read the purge air flow rate from the charts and calculate the "required outlet air flow rate + purge air flow rate".

The air supply capacity must be at least equal to the calculated flow or the required outlet air flow rate cannot be obtained.

2. Selection for a compressed air line in which a mist separator or micro mist separator is already installed

Confirm the operating air flow rate and pressure, and select a membrane air dryer in accordance with the model selection method (page 4.2-38). If a membrane air dryer is selected based on the port sizes of previously installed equipment, a model may be selected which is too small and the dehumidification capacity may be insufficient.

3. With fittings for purge air discharge (Option: P)

As the length of the tubing for purge air discharge increases, dehumidification performance decreases. Use the specified tubing size and keep the length within 5 meters or less. Refer to "Outlet air atmospheric pressure dew point by purge air discharge tube length" on pages 4.2-4 and 4.2-11 for information on this subject.

4. Auto drain selection for the unit style

When the compressor being used is 2.2kW {300ℓ/min (ANR)} or less, use a N.C. auto drain (Symbol: C). If a N.O. auto drain (Symbol: D) is used at 2.2kW or less, the unit may blow continuously without pressure rising inside the mist separator. However, a differential pressure type auto drain can be used even at 2.2kW or less.

Mounting

⚠ Caution

1. Do not obstruct the purge air discharge ports.

If purge air back pressure becomes too high or purge air stops flowing, dehumidification performance will decrease or become impossible.

2. Be sure to install a mist separator and micro mist separator or a micro mist separator with pre-filter on the upstream side of the membrane air dryer.

If the inlet air contains oil or water drops, etc., performance will be reduced. (A mist separator and micro mist separator or a micro mist separator with pre-filter are already installed on the unit types.)

3. Install a regulator on the downstream side of the membrane air dryer.

If it is installed on the upstream side, dehumidification performance will be reduced.

4. Use adequate care in handling.

There is a danger of damage if dropped.

HA

IDG

AMG

AFF

AM

FQ1

Related products



Series IDG

Specific Product Precautions 2

Be sure to read before handling.

Piping

⚠ Warning

1. Confirm locking of case and body.

When using in a unit, be sure to set the air pressure to zero before using a mist separator or micro mist separator with modular connections. Also, confirm that the body and case are locked together with a click before starting the flow of compressed air.

2. Confirm tightening of the holder.

(for IDG30 to IDG100, IDG30H to IDG100H, IDG30L to IDG100L and IDG60S to IDG100S)

Before starting the flow of compressed air, turn the membrane air dryer's holder in its tightening direction, confirming that it is completely tightened and that the case will not come off.

3. Minimum bending radius

(for IDG1)

When installing piping for the membrane air dryer, maintain a minimum bending radius of 35mm or more. Furthermore, do not bend the sections that are within 50mm of the ends of the membrane module.

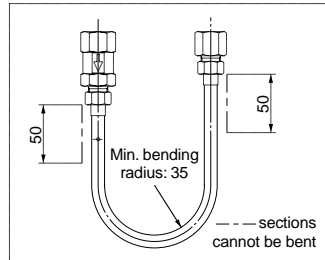

4. With fittings for purge air discharge

(Option: P)

The piping of purge air for dehumidification and for the dew point checker can be combined, but do not merge these with compressed air lines or drain piping, etc., as this can cause damage.

Piping

⚠ Caution

1. Use of tools

Hold the upper portion of the body (die-cast aluminum section) with a spanner or adjustable angle wrench. Do not turn it while holding the case section.

2. Drain piping for separators

When installing drain piping for mist separators or micro mist separators, use the prescribed tubing size and keep the length within 5 meters or less.

Also, be sure that the tubing does not stand up or become folded over.

3. Piping materials for low dew point air

When air with a low dew point (-40°C or less) is required, do not use nylon tubing for the membrane air dryer's downstream piping. A characteristic of nylon tubing is that it is affected by the ambient air, and it may not be possible to obtain the specified low dew point at the end of the tube. For low dew point air, use stainless steel or fluororesin piping.

4. With fittings for purge air discharge

(Option: P)

(for IDG60 to IDG100, IDG60H to IDG100H, IDG60L to IDG100L and IDG60S to IDG100S)

To install piping for dehumidification purge air discharge, attach tubing of the prescribed size to the hose nipple section and then secure it with tubing bands.

Air Supply

⚠ Caution

1. Compressed air supply capacity

An air supply is necessary which has a supply capacity at least equal to the "required outlet air flow rate (dry air flow rate) + purge air flow rate". Confirm the purge air flow rate with the purge air flow rate charts (page 4.2-43).

Operating Environment

⚠ Caution

1. Do not use at temperatures (fluid or ambient temperatures) higher than the prescribed operating conditions.

Resin is used in the membrane module, and it can be damaged by operation at high temperatures. Especially when installed immediately after a reciprocating type air compressor, confirm that the fluid temperature does not exceed the range of operating conditions during use.

2. Keep the inlet air temperature lower than the ambient temperature.

If the membrane air dryer's body is cooled by the surrounding air, water drops may accumulate inside and reduce its dehumidification capacity.



Series IDG

Specific Product Precautions 3

Be sure to read before handling.

Maintenance

⚠ Warning

1. Do not remove the orifice (plug) when in a pressurized state.

Never remove the orifice (plug) while under pressure, as it can fly out causing a hazard.

⚠ Caution

1. Confirming the dehumidification function with the dew point indicator

Observe the colour of the dew point indicator to confirm whether the membrane air dryer is functioning normally.

[When dew point indicator colour is blue: Functioning normally]

[When dew point indicator colour is pink: Dew point temperature is high (outlet air is moist) Note: Atmospheric pressure dew point is approx. -10°C or more]

It takes about 1 hour from the start of air flow for the dew point indicator colour to change.

2. Confirmation of oil contamination with the dew point indicator

When the dew point indicator colour turns brown, a large amount of oil has contaminated the membrane air dryer. In this case, replace the dew point indicator and membrane module.

3. Element replacement period

The elements of the mist separator and micro mist separator or micro mist separator with pre-filter, which are installed on the inlet side of the membrane air dryer, should be replaced after about two years of use.

Even within this period, replace the element if the drop in the unit's pressure reaches 0.2MPa. When equipped with a micro mist separator with pre-filter, replace the element when the red portion of the element service indicator reaches completely to the top.

Refer to the order made specifications on page 4.2-34 regarding the element service indicator for confirmation of pressure drop.

4. Membrane module replacement period

Replace the membrane module if the dew point indicator's colour turns white, pink or brown.

When periodic replacement is to be performed, the schedule will depend on the operating conditions, but as a general rule replacement should be performed after four years of use. Even within this period, replace the module if the dew point indicator's colour changes to any of the colours mentioned above.

5. Tightening torque for mounting of membrane module and case (for IDG5, 10, 20, 5H, 10H, 20H)

Tighten within the prescribed tightening torque range.

Tightening outside of this range can cause damage to the membrane module, case and mounting screws, or cause poor sealing, etc.

(Confirm the tightening torque range in the instruction manual.)

6. Pressure gauge installation

A pressure gauge should be installed on the entry side of the membrane air dryer (unit) for maintenance and inspection purposes.

HA□

IDG

AMG

AFF

AM□

FQ1

Related products

